

Contents

HP E1415A and HP E1419A Service Manual

Chapter 1	
General Information	5
Introduction.....	5
Safety Information	6
WARNINGS	6
CAUTIONS	7
Controller Description	8
Specifications	8
Environment	8
Signal Conditioning Plug-Ons (SCPs)	8
Service Programs Disk.....	9
Recommended Test Equipment.....	10
Chapter 2	
Verification Tests	11
Introduction.....	11
Test Conditions & Procedures	11
Performance Test Record	11
Verification Test Programs	11
Functional Verification Tests.....	12
Test F-1: Self-Test	12
Test F-2: Overrange Detection	13
Test F-3: Open Transducer Detection	15
Performance Verification Tests	17
Operation Verification Tests	17
Performance Verification Test Conditions	17
Performance Verification Test Programs	17
Test 2-1: DCV Accuracy - E1501A	20
Test 2-2: DCV Accuracy - E1502A & E1512A	20
Test 2-3: DCV Accuracy - E1503A (Gain X1)	24
Test 2-4: DCV Accuracy - E1503A (Gain X8)	24
Test 2-5: DCV Accuracy - E1503A (Gain X64)	24
Test 2-6: DCI Accuracy - E1505A	29
Test 2-7: Excitation Voltage Accuracy - E1506A	32
Test 2-8: Excitation Voltage Accuracy - E1507A	32
Test 2-9: DCV Accuracy - E1508A	35
Test 2-10: DCV Accuracy - E1509A	35
Test 2-11: Sample&Hold DCV Accuracy and Droop - E1510A	39
Test 2-12: Sample&Hold DCV Accuracy and Droop - E1511A	39
Test 2-13: DCV Accuracy, Straight-Through Channels -- E1510A	44
Test 2-14: Excitation Voltage Measurement -- E1511A	45
Test 2-15: DCV Accuracy -- E1512A	47
Test 2-16: DCV Accuracy - E1513A	48
Test 2-17: DCV Accuracy - E1514A and E1515A	51
Test 2-18: DCV Accuracy - E1516A and E1517A	54
Test 2-19: DCI Accuracy - E1518A	57
Test 2-20: DCV Accuracy - E1518A	60
Test 2-21: DCV Output Accuracy - E1531A	63

Test 2-22: DCI Output Accuracy - E1532A	65
Test 2-23: 16-Bit Digital I/O - E1533A	67
Test 2-24: 8-Bit Frequency/Totalize/PWM - E1534A	69
Test 2-25: Watchdog Timer - E1535A	71
Test 2-26: 8-Bit Isolated Digital I/O - E1536A	73
Test 2-27: DCV Output Accuracy - E1537A	75
Test 2-28: Enhanced Frequency/Totalize/PWM - E1538A	77
Performance Test Record.....	81
Test Limits	81
Measurement Uncertainty	81
Test Accuracy Ratio (TAR)	81

Chapter 3

Adjustments	119
Introduction.....	119
Recommended Equipment & Environment	119
Flash Memory Access	119
A/D Adjustment Procedure.....	120
Description	120
Adjustment Procedure	124
Adjustment Program	127

Chapter 4

Replaceable Parts	129
Introduction.....	129
Exchange Modules.....	129
Replaceable Parts Lists	129
Component Locators.....	130

Chapter 5

Service	137
Introduction.....	137
Equipment Required	137
Service Aids	137
Recommended Repair Strategy	137
Troubleshooting Guidelines.....	138
Running Service Test Program	138
Troubleshooting	139
Checking SCPs	139
Disassembly	140
Repair/Maintenance Guidelines.....	143
ESD Precautions	143
Introduction.....	145
HP E1415A and HP E1419A Accuracy Calculations	146
DCV Accuracy Equations	146
DCI Accuracy Equations	153
Frequency, Pulse and Pulse Width Accuracy Equations	155
Measurement Uncertainty Calculations.....	157

DC Source Measurement Uncertainty	157
DMM Measurement Uncertainty	158
AC Signal Source Uncertainty	158
Counter/Totalizer Pulse Width Measurement Uncertainty	159
Test Accuracy Ratio (TAR) Calculations	160
Self Test Error Messages	161
Introduction.....	173
CALibration Commands.....	173
A/D Calibration	173
Working Calibration	173
CALibration:CONFigure:RESistance	174
CALibration:CONFigure:VOLTagE	175
CALibration:SETup	176
CALibration:SETup?	176
CALibration:STORe	177
CALibration:TARE	178
CALibration:TARE:RESet	179
CALibration:TARE?	180
CALibration:VALue:RESistance	180
CALibration:VALue:VOLTagE	181
CALibration:ZERO?	182
DIAGnostic	183
DIAGnostic:CALibration:SETup[:MODE]	183
DIAGnostic:CALibration:SETup[:MODE]?	184
DIAGnostic:CALibration:TARE[:OTDetect]:MODE	184
DIAGnostic:CALibration:TARE[:OTDetect]:MODE?	185
DIAGnostic:CHECKsum?	185
DIAGnostic:CUSTom:LINear	186
DIAGnostic:CUSTom:PIECewise	186
DIAGnostic:CUSTom:REFerence:TEMPerature	187
DIAGnostic:FLOOR[:CONFigure]	188
DIAGnostic:FLOOR:DUMP	188
DIAGnostic:IEEE	189
DIAGnostic:IEEE?	189
DIAGnostic:INTerrupt[:LINE]	189
DIAGnostic:INTerrupt[:LINE]?	190
DIAGnostic:OTDetect[:STATE]	190
DIAGnostic:OTDetect[:STATE]?	191
DIAGnostic:QUERy:SCPREAD?	192
DIAGnostic:VERSion?	192
Common Commands	193
*CAL?	193
*CLS	193
*ESE <mask>	194
*ESE?	194
*ESR?	194

*IDN?	194
*OPC	195
*OPC?	195
*RST	195
*SRE <mask>	196
*SRE?	196
*STB?	196
*TRG	196
*TST?	196
*WAI	199

Chapter 1

General Information

Introduction

This service manual contains information to test, troubleshoot, and repair the HP E1415A Algorithmic Closed Loop Controller, the HP E1419A Multifunction^{Plus} Measurement and Control and the associated Signal Conditioning Plug-Ons (SCPs). Figure 1-1, “HP E1415A and HP E1419A Module,” shows a typical E1415A or E1419A module and the SCPs described in this manual.

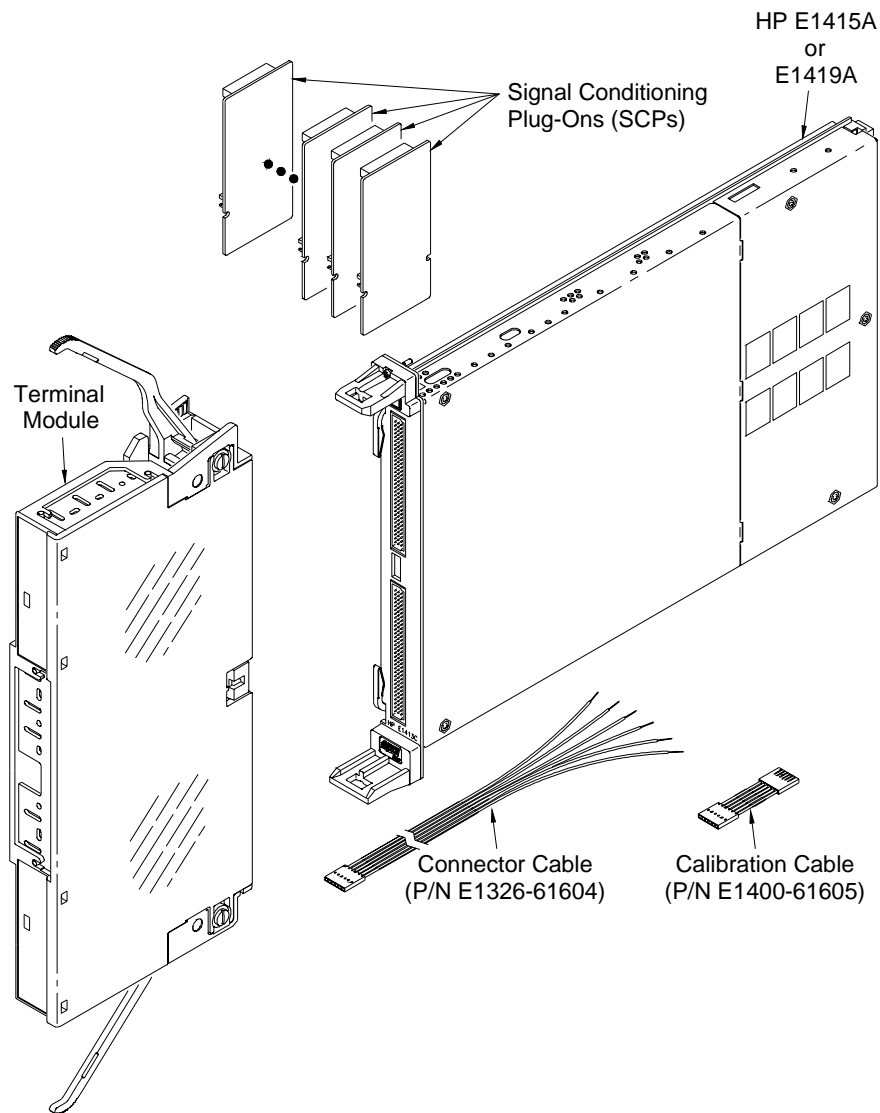

Figure 1-1. HP E1415A and HP E1419A Module

Safety Information

The HP E1415A and the HP E1419A are Safety Class I instruments that are provided with a protective earth terminal when installed in the mainframe. Check the mainframe and all related documentation for safety markings and instructions before operating or servicing either module.

See the WARNINGS on page 4 for a summary of safety information. Safety information to test and service the HP E1415A or HP E1419A follows. Other safety information is also found throughout this manual.

WARNINGS

Follow the WARNINGS listed to avoid possible injury to yourself or others when operating, repairing, or servicing either an HP E1415A or and HP E1419A.

WARNING

SERVICE-TRAINED PERSONNEL ONLY. The information in this manual is for service-trained personnel who are familiar with electronic circuitry and are aware of the hazards involved. To avoid personal injury or damage to the instrument, do not perform procedures in this manual or do any servicing unless you are qualified to do so.

CHECK MAINFRAME POWER SETTINGS. Before applying power, verify that the mainframe setting matches the line voltage and the correct fuse is installed. An uninterruptible safety earth ground must be provided from the main power source to the supplied power cord set.

GROUNDING REQUIREMENTS. Interruption of the protective (grounding) conductor (inside or outside the mainframe) or disconnecting the protective earth terminal will cause a potential shock hazard that could result in personal injury. (Grounding one conductor of a two-conductor outlet is not sufficient protection.)

IMPAIRED PROTECTION. Whenever it is likely that instrument protection has been impaired, the mainframe must be made inoperative and be secured against any unintended operation.

REMOVE POWER IF POSSIBLE. Some procedures in this manual may be performed with power supplied to the mainframe while protective covers are removed. Energy available at many points may, if contacted, result in personal injury. (If service can be performed without power applied, remove the power.)

WARNING **USING AUTOTRANSFORMERS.** If the mainframe is to be energized via an autotransformer (for voltage reduction) make sure the common terminal is connected to neutral (that is, the grounded side of the main's supply).

USE PROPER FUSES. For continued protection against fire hazard, replace the line fuse(s) only with fuses of the same current rating and type (such as normal blow, time delay, etc.). Do not use repaired fuses or short-circuited fuse holders.

CAUTIONS

Follow the CAUTIONS listed to avoid possible damage to the equipment when performing instrument operation, service, or repair.

Caution **MAXIMUM INPUT VOLTAGE/CURRENT.** To avoid possible damage to the instrument, maximum input voltage (normal mode plus common mode) is ± 42 V_{peak}. Maximum operating voltage is ± 16 V_{peak}. Maximum current per channel or common: 100 mA DC or AC RMS.

STATIC ELECTRICITY. Static electricity is a major cause of component failure. To prevent damage to the electrical components in the module or SCPs, observe anti-static techniques when removing an HP E1415A/E1419A from the mainframe or when handling an HP E1415A/E1419A or SCP. Also, be sure to tighten the front panel screws when installing an HP E1415A or HP E1419A in a mainframe slot.

Controller Description

The HP E1415A and HP E1419A modules are VXIbus C-Size instruments that are digital sampling closed loop control systems on a single module. They operate in a VXIbus mainframe using a Command Module and Standard Commands for Programmable Instruments (SCPI).

The modules have a variety of signal conditioning plug-ons for making measurements of:

- Voltage, current, resistance
- Temperature, strain
- RPM, frequency, totalize
- Discrete levels, TTL, contact closures.

Specifications

See *Appendix A* for HP E1415A Algorithmic Closed Loop Controller, HP E1419A Multifunction^{Plus} Measurement and Control and SCP specifications. These specifications are the performance standards or limits against which the instrument may be tested.

Environment

The HP E1415A or HP E1419A and SCPs should be stored in a clean, dry environment. Recommended operating/storage environments for the modules and SCPs are:

Table 1-1. Environmental Specifications

	Temperature	Relative Humidity
Operating Environment	0°C to +55°C	<65% (0°C to +40°C)
Storage/Shipment	-40°C to +75°C	<65% (0°C to +40°C)

Signal Conditioning Plug-Ons (SCPs)

SCPs for the HP E1415A Algorithmic Closed Loop Controller and the HP E1419A Multifunction^{Plus} Measurement and Control contained in this manual include:

Table 1-2. Signal Conditioning Plug-Ons (SCP)

SCP Model Number	Description	SCP Model Number	Description	SCP Model Number	Description
E1501A	Direct Input	E1510A	4 Channel Sample & Hold	E1531A	Voltage Output
E1502A	Low Pass Filter Input	E1511A	4 Channel Transient Strain	E1532A	Current Output
E1503A	Gain/Filter Input	E1512A	8 Channel 25Hz Low Pass	E1533A	Digital Input/Output
E1504A	Breadboard (no tests)	E1513A	Attenuator Input / 16	E1534A	Freq/Totalize/PWM
E1505A	Current Source	E1514A	Iso x1, 4 Channel 10Hz LP	E1535A	Watchdog Timer
E1506A	120 Ω Strain Gage	E1515A	Iso x1, 4 Channel 100Hz LP	E1536A	Isolated Digital I/O
E1507A	350 Ω Strain Gage	E1516A	Iso x64, 4 Channel 10Hz LP	E1537A	Voltage Output
E1508A	Fixed Gain/Filter Input	E1517A	Iso x64, 4 Channel 100Hz LP	E1538A	Freq/Totalize/PWM
E1509A	Fixed Gain/Filter Input	E1518A	Resistance Measurement		

Service Programs Disk

An HP E1415A/E1419A Service Programs disk is shipped with this manual. The programs on the disk are in ANSI C language using HP VISA. The disk is DOS formatted, the programs were written in Microsoft® Visual C++ but the programs should compile under any standard ANSI C compiler. *The files on the disk can be read by any standard ASCII editor.*

To run the programs you must have the HP I/O Library (SICL/VISA), SCPI Instrument Drivers, VXIplug&play Drivers, and an HP 82341, or equivalent, HP-IB module installed and properly configured in your computer.

The following table lists the programs on the disk.

Table 1-3. HP E1415A and HP E1419A Service Programs

Chap	Category	filename	Test Description
2 & 5	Functional Verification Tests	SELFTTEST.C	Performs self-test of the HP E1415A or HP E1419A
		OVERRANG.C	Tests overrange detection function
		OPENTRAN.C	Tests open transducer detection (OTD) function
	Performance Verification Tests	PERF01.C	Tests DC voltage accuracy using E1501A SCP
		PERF02_12.C	Tests DC voltage accuracy using E1502A or E1512A SCP
		PERF0301.C	Tests DC voltage accuracy using E1503A SCP @ Gain X1
		PERF0308.C	Tests DC voltage accuracy using E1503A SCP @ Gain X8
		PERF0364.C	Tests DC voltage accuracy using E1503A SCP @ Gain X64
		PERF05.C	Tests current accuracy using E1505A SCP
		PERF06_07.C	Tests excitation voltage accuracy using E1506A SCP or E1507A SCP
		PERF08.C	Tests DC voltage accuracy using E1508A SCP
		PERF09.C	Tests DC voltage accuracy using E1509A SCP
		PERF10SH.C	Tests 4 Sample & Hold Channels DC voltage accuracy using E1510A SCP
		PERF10ST.C	Tests 4 Straight-Through Channels DC voltage accuracy using E1510A SCP
		PERF11.C	Tests DC voltage accuracy and Excitation voltage using E1511A SCP
		PERF13.C	Tests DC voltage accuracy using E1513A SCP
		PERF14_15.C	Tests DC voltage accuracy using E1514A or E1515A SCP
		PERF16_17.C	Tests DC voltage accuracy using E1516A or E1517A SCP
		PERF18V.C	Tests DC voltage accuracy using E1518A SCP (4 channels)
PERF18i.C	Tests DC current accuracy using E1518A SCP (4 channels)		
PERF31.C	Tests DC voltage output accuracy using E1531A SCP		

Table 1-3. HP E1415A and HP E1419A Service Programs

Chap	Category	filename	Test Description
		PERF32.C	Tests DC current output accuracy using E1532A SCP
		PERF33.C	Tests 16-bit Digital I/O operation using E1533A SCP
		PERF34.C	Tests frequency, totalize and PWM using E1534A SCP
		PERF35.C	Tests the timing and alarm of the E1535A SCP
		PERF36.C	Tests 8-bit isolated Digital I/O operation using E1536A
		PERF37.C	Test the DC voltage output accuracy using E1537A
		PERF38.C	Tests frequency, totalize and PWM using E1538A SCP
3	Adjustments	ADJSPROC.C	Performs internal A/D adjustments

Recommended Test Equipment

See Table 1-4 for test equipment recommended to test and service the HP E1415A, the HP E1419A and SCPs. Essential requirements for each piece of test equipment are listed in the *Requirements* column. You may substitute other equipment if it meets the requirements listed in the table.

Table 1-4. Recommended Test Equipment

Instrument	Requirements	Recommended Model	Use
Controller, HP-IB	HP-IB compatibility as defined by IEEE Standard 488-1987 and the identical ANSI Standard MC1.1: SH1, AH1, T2, TE0, L2, LE0, SR0, RL0, PP0, DC0, DT0, and C1, 2, 3, 4, 5	IBM Compatible PC with HP 82340, 82341 or 82350 HP-IB module	F,P
Mainframe	Compatible with HP E1405B or HP E1406A Command Module	HP E1401B/T or E1421B (requires HP E1405B or E1406A)	F,P
Digital Multimeter	Voltage Range: ± 20 Vdc Resistance Range: 1 M Ω Current Range: 100 μ A to 1 mA DC	HP 3458A	A,T
Voltage Source	Voltage Range: ± 20 Vdc	Datron 4708 Option 10	F,P
Counter	Ability to make pulse width measurements from 7 μ S to 1 mS. Resolution < 200 nS.	HP E1332A Counter/Totalizer	P
*A = Adjustments, F = Functional Verification Tests, P = Performance Verification Tests, T = Troubleshooting			

Introduction

The three levels of test procedures described in this chapter are used to verify that the HP E1415A or HP E1419A and associated Signal Conditioning Plug-Ons (SCPs)

- are functional (Functional Verification)
- meet selected testable specifications (Operation Verification)
- meet all testable specifications (Performance Verification)

WARNING Do not perform any of the following verification tests unless you are a qualified, service-trained technician and have read the WARNINGS and CAUTIONS in Chapter 1.

Test Conditions & Procedures

See Table 1-4 for test equipment requirements. You should complete the performance verification tests on a periodic basis, as required. For best results, the test environment temperature should be $23^{\circ}\text{C} \pm 1^{\circ}\text{C}$.

The verification tests assume that the person performing the tests understands how to operate the mainframe, the E1415 or E1419, and specified test equipment. The test procedures do not specify equipment settings for test equipment, except in general terms. It is assumed a qualified, service-trained technician will select and connect any cables, adapters, and probes required for the test.

Performance Test Record

Record the results of each performance verification test in Table 2-1, *HP E1415A/E1419A Performance Test Record*. Copy the form as needed.

Verification Test Programs

There is a performance verification test program for each SCP. Each verification test is included on the *HP E1415A/E1419A Service Programs* disk sent with this manual. All programs assume the following:

- Controller is a PC
- Programming language is ANSI C
- Module address is 70926 (logical address is 208)
- DMM is an HP 3458A at address 722
- HP E1332A Counter/Totalizer at address 70906 (logical address is 48)

Functional Verification Tests

The purpose of the functional verification tests is to verify that the E1415/E1419 is functioning properly. No attempt is made to verify that the instrument is meeting specifications. Functional verification tests include:

- Test F-1: Self-Test
- Test F-2: Controller Overrange Detection
- Test F-3: Open Transducer Detection

Note For a quick functional check of the E1415/19, perform only the Self-Test.

Test F-1: Self-Test

Test Program Description The self-test (test program SELFTEST.C) provides a high degree of confidence that the instrument is functional. The self-test may take several minutes.

Note During the first 5 minutes after power-on, the self-test may fail. Allow the instrument to warm up before running the self-test.

Test Summary **1 Execute the self-test**

*TST? *Self-test command*

2 Read the result

ENTER statement *"0" = test passed. Any other number = self-test failure.*

Self-Test Program Run the "SELFTEST" program to perform a self-test of the E1415/E1419. The test also identifies installed SCPs and tests for system errors. If the self-test passes, the display is: **Self-test PASSED**.

If the self-test fails, it will display the error number, for example:

Self Test Error: 3052

Note Refer to Appendix B for a list of error messages.

Test F-2: Overrange Detection

Test Program Description

This test (test program OVERRANG.C) checks the DCV overrange detection function of the E1415/E1419. An input of ± 17 Vdc is applied with the module set to the 16V range. The result should be an overrange indication ($\pm 9.9E+37$). *This test applies to only the E1501A through E1503A, E1508A through E1512A, E1514A, and E1515A SCPs.*

Test Summary 1 Make Equipment Connections

- Set up the equipment as shown in Figure 2-1. Connections are shown to channel 07. You can connect inputs to any channel.
- Be sure the desired SCP is installed for the channel(s) tested.

WARNING The DC Standard (Datron 4708, Option 10) can produce dangerous voltages that are present on the terminals. Do not touch the front (or rear) panel terminals unless you are sure no dangerous voltage is present.

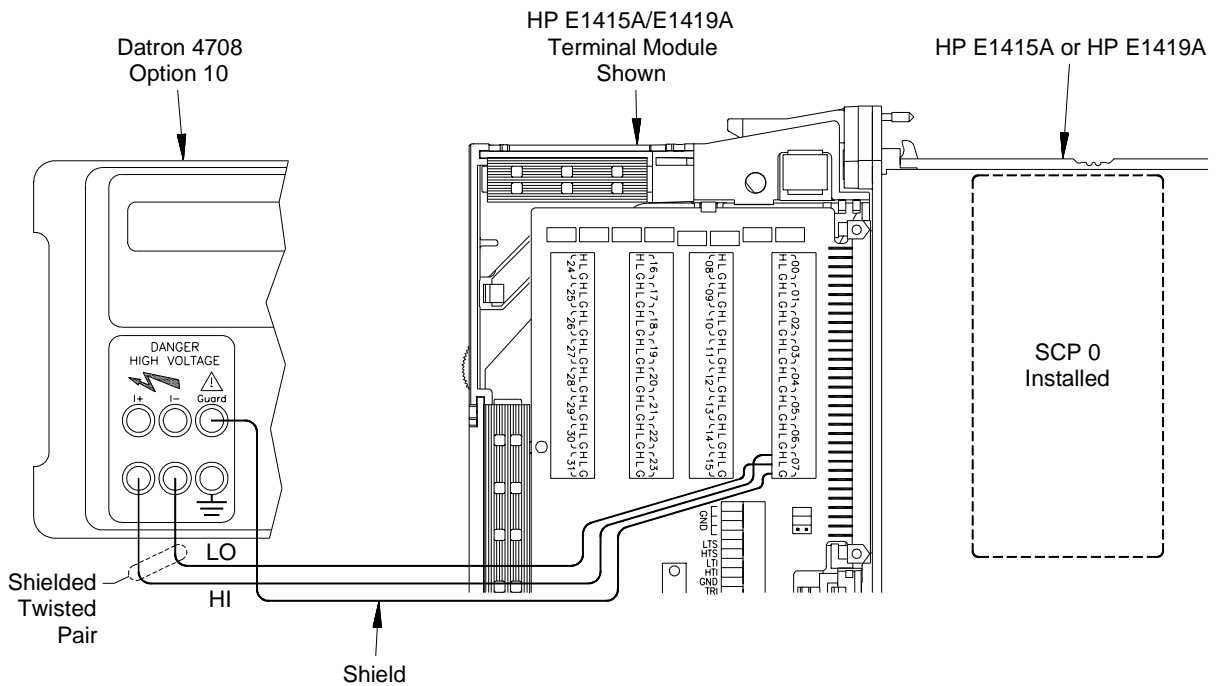

Figure 2-1. Overrange Detection Test Connections

2 Set up the Module

Test with +17 Vdc applied (Input to channel 07 illustrated)

*RST;*CLS;*OPC?	<i>Reset Scan and clear status register</i>
ENTER statement	<i>*OPC? response</i>
FUNC:VOLT 16, (@107)	<i>Set voltage meas, 16V range on ch 07</i>

3 Trigger the Module

INIT	<i>Set Wait For Trigger state</i>
TRIG	<i>Trigger the instrument</i>

4 Read measurement from Current Value Table

DATA:CVT? (@107)	<i>Reads channel 07 voltage from CVT</i>
ENTER statement	<i>Returns reading - should be 9.9E+37</i>

5 Repeat Steps 3 and 4 for -17 Vdc input

Overrange Test Program

Run the "OVERRANG" program to perform an overrange check for +17 Vdc and -17 Vdc input to the HPE1415/E1419. Typical results when the test passes are:

+17 Vdc overrange indication = 9.9E+37

-17 Vdc overrange indication = -9.9E+37

Test F-3: Open Transducer Detection

Test Program Description

This test (test program OPENTRAN.C) checks the HP E1415A "Open Transducer Detection (OTD)" capability. To do this test, an input short is applied and the channel voltage is measured. Then, the input is opened and the channel voltage is again measured. The short should return <1 Vdc and the open should return $9.9E+37$ (overrange). *This test applies to only the E1501A through E1503A, E1508A through E1512A, and E1518A (Channels 4 - 7 only) SCPs.*

Note

Enabling any SCP channel for OTD selects all eight channels on that SCP. Thus, an open transducer on any channel to an enabled SCP results in an OTD indication for the SCP. You will need to determine which channel(s) have open transducers.

Test Summary

1 Make Equipment Connections

- Set up the equipment as shown in Figure 2-2. Connections are shown for channel 07 - modify as required.
- Be sure the desired SCP is installed for the channel tested.

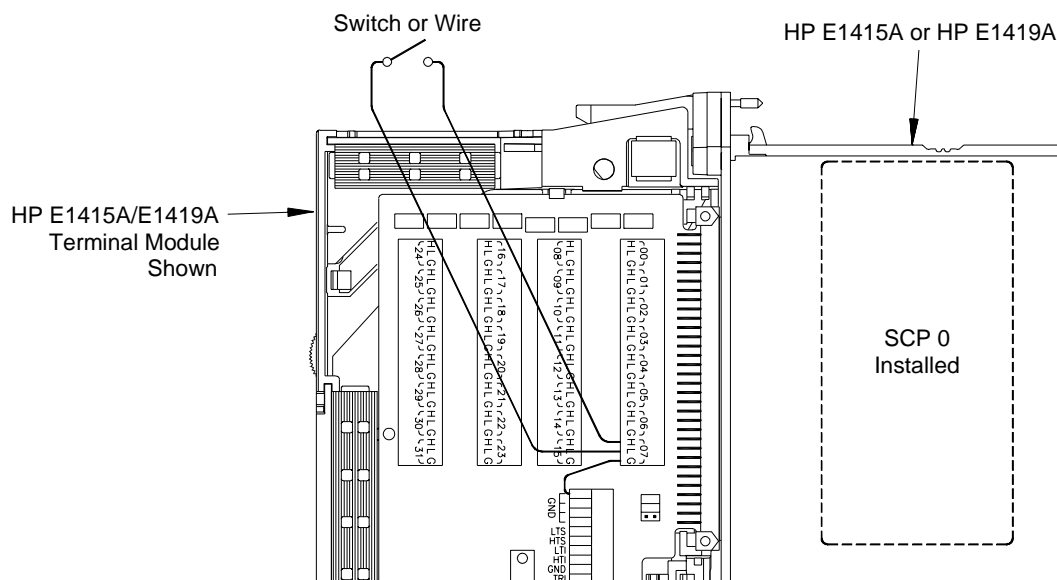

Figure 2-2. Open Transducer Detection Connections

2 Set up the Module

Test with short applied to module (channel 07 illustrated)

*RST;*CLS;*OPC?

Reset and clear status register

ENTER statement
FUNC:VOLT 4, (@107)
DIAG:OTD ON, (@107)

**OPC? response
Set for voltage meas, 4V range
on channel 07
Enable OTD on channels 00 - 07
(SCP 0)*

3 Trigger the Module

INIT
WAIT 15
TRIG

*Set Wait For Trigger state
Filter settling time
Trigger the module*

4 Read measurement from Current Value Table

DATA:CVT? (@107)
ENTER statement

*Read channel 07 voltage from
CVT
Return reading - should be <1
Vdc*

5 Repeat Steps 3 and 4 for open input. Reading for this test should be 9.9E+37 (overrange).

Open Transducer Test Program

Run the "OPENTRAN" program to perform an open transducer check. A typical result for this test is:

Shorted input value = 0.002929 Vdc
Open input value = 9.9E+37 Vdc

Performance Verification Tests

The procedures in this section are used to test the HP E1415/E1419 DC voltage accuracy using the 90-day specifications in *Appendix A* as the performance standards. The results of each performance verification test can be recorded on the *Performance Test Record* (Table 2-1 at the end of this chapter).

Operation Verification Tests

For the HP E1415A or HP E1419A, Operation Verification tests are the same as the Performance Verification tests. If a performance verification test fails, adjust the instrument using the procedures in Chapter 3 - Adjustments and then rerun the test. If the test fails again, return to your nearest Hewlett-Packard service center for possible replacement.

Performance Verification Test Conditions

The assumed conditions for the performance verification tests are based on the following specifications/conditions:

- Minimum 1 hour warm-up for the HP E1415/E1419 and DC Standard
- Test environment temperature $23^{\circ}\text{C} \pm 1^{\circ}\text{C}$
- Linearity = \pm % of reading (90-day specifications)
- *CAL? command executed before measurements. Executing CAL:TARE automatically executes *CAL?.
- CAL:ZERO? executed within 5 minutes after *CAL?

Performance Verification Test Programs

The table on the next page summarizes HP E1415/E1419 performance verification tests. The *filename* in the table refers to the name of the verification test program on the *Service Programs* disk. Full and complete verification procedures are best viewed by printing the program for the SCP you are testing.

The programs on the disk are in standard ANSI C language using HP I/O Libraries (SICL/VISA). The disk is DOS formatted and the programs can be opened into any standard DOS editor. The programs were written and verified in Microsoft[®] Visual C++, on an HP Vectra computer, with an HP 82341 HP-IB interface installed in the computer. The programs should compile under any standard ANSI C compiler.

To run the programs you must have the HP I/O Library (SICL/VISA), SCPI Instrument Drivers, VXIplug&play Drivers, and an HP 82341 (or equivalent) HP-IB module installed and properly configured in your computer.

Note

View complete performance verification test procedures by opening the SCP test program source file in any standard DOS editor. You can print a hard copy version to view along with this chapter. The test summaries provided in this chapter are simply "summaries" which supplement the test set-up diagrams. These test summaries support the test programs but are not intended to provide a full replacement in a written format.

**HP E1415A and HP E1419A
Performance Verification
SCP Test Program List**

Test	Test Name	Test Description	SCP/Gain	Filename
2-1	DCV Accuracy - E1501A	DC voltage accuracy for the .0625V, .25V, 1.0V, 4.0V, and 16.0V ranges	E1501A Gain X1	PERF01.C
2-2	DCV Accuracy - E1502A and E1512A	DC voltage accuracy for the .0625V, .25V, 1.0V, 4.0V, and 16.0V ranges	E1502A & E1512A Gain X1	PERF02_12.C
2-3	DCV Accuracy - E1503A (Gain X1)	DC voltage accuracy for the .0625V, .25V, 1.0V, 4.0V, and 16.0V ranges and 2Hz, 10Hz, 100Hz filters or filter OFF	E1503A Gain X1	PERF0301.C
2-4	DCV Accuracy - E1503A (Gain X8)	DC voltage accuracy for the .0625V, .25V, 1.0V, 4.0V, and 16.0V ranges and 2Hz, 10Hz, 100Hz filters or filter OFF	E1503A Gain X8	PERF0308.C
2-5	DCV Accuracy - E1503A (Gain X64)	DC voltage accuracy for the .0625V, .25V, 1.0V, 4.0V, and 16.0V ranges and 2Hz, 10Hz, 100Hz filters or filter OFF	E1503A Gain X64	PERF0364.C
2-6	DCI Accuracy - E1505A	DC current accuracy for the 30 μ A and 488 μ A ranges	E1505A	PERF05.C
2-7	Excitation Voltage Accuracy - E1506A	3.9 Vdc excitation voltage accuracy	E1506A	PERF06_07.C
2-8	Excitation Voltage Accuracy - E1507A	3.9 Vdc excitation voltage accuracy	E1507A	PERF06_07.C
2-9	DCV Accuracy -E1508A	DC voltage accuracy for the .0625V, .250V, 1.0V, 4.0V, and 16.0V ranges	E1508A Gain X16	PERF08.C
2-10	DCV Accuracy - E1509A	DC voltage accuracy for the .0039V, .0156V, .0625V, and .25V ranges	E1509A Gain X64	PERF09.C
2-11	DCV Accuracy - E1510A S&H channels.	DC voltage accuracy and sample & hold droop for the 4 sample & hold channels	E1510A all gains	PERF10SH.C
2-12	DCV Accuracy - E1511A	DC voltage accuracy and sample & hold droop for the 4 Bridge Sense (Sample & Hold) channels	E1511A all gains	PERF11.C
2-13	DCV Accuracy - E1510A Straight- Through channels	DC voltage accuracy for the .0625V, .250V, 1.0V, 4.0V, and 16.0V ranges	E1510A Gain X1	PERF10ST.C
2-14	Excitation Voltage - E1511A	1, 2, 5, and 10 volt Excitation Voltage measurement	E1511A	PERF11.C
2-15	DCV Accuracy - E1512A	DC voltage accuracy for the .0625V, .25V, 1.0V, 4.0V, and 16.0V ranges	E1512A Gain X1	PERF02_12.C
2-16	DCV Accuracy - E1513A	DC voltage accuracy for the 1.0V and 4.0V ranges	E1513A Gain \div 16	PERF13.C
2-17	DCV Accuracy - E1514A and E1515A	DC voltage accuracy for the 16V range	E1514A & E1515A Gain X1	PERF14_15.C

Test	Test Name	Test Description	SCP/Gain	Filename
2-18	DCV Accuracy - E1516A and E1517A	DC voltage accuracy for the 4V range	E1516A & E1517A Gain X64	PERF16_17.C
2-19	DCI Accuracy - E1518A (ch 00-03)	DC current accuracy for the 30 μ A and 488 μ A ranges	E1518A	PERF18i.C
2-20	DCV Accuracy - E1518A (ch 04-07)	DC voltage accuracy for the .0625V, .25V, 1.0V, 4.0V, and 16.0V ranges	E1518A Gain X1	PERF18V.C
2-21	DCV Accuracy - E1531A	DC voltage output source accuracy	E1531A	PERF31.C
2-22	DCI Accuracy - E1532A	DC current output source accuracy	E1532A	PERF32.C
2-23	Digital I/O verification - E1533A	Digital output and input functions	E1533A	PERF33.C
2-24	Freq/PWM verification - E1534A	Frequency counter, frequency source and pulse source accuracy	E1534A	PERF34.C
2-25	Alarm verification - E1535A	Timer and alarm functioning	E1535A	PERF35.C
2-26	Digital I/O verification - E1536A	Digital output and input functions	E1536A	PERF36.C
2-27	DCV Accuracy - E1537A	DC voltage output source accuracy	E1537A	PERF37.C
2-28	Freq/PWM verification - E1538A	Frequency counter, frequency source, pulse width measurement and pulse source accuracy	E1538A	PERF38.C

Test 2-1: DCV Accuracy - E1501A

Test 2-2: DCV Accuracy - E1502A & E1512A

Test Program Description Test 2-1 (test program PERF01.C) checks HP E1415A or E1419A DC voltage measurement accuracy when an E1501A Straight-Through SCP is used. Test 2-2 (test program PERF02_12.C) checks DCV accuracy when an E1502A or E1512A Fixed Filter SCP is used.

Note View complete performance verification test procedures by opening the SCP test program source file in any standard word processor (e.g., MS WORD, WordPad, Notepad, etc.). You can print a hard copy version to view along with this chapter. The test descriptions provided in this chapter are simply "summaries" which supplement the test set-up diagrams. These test summaries support the test programs but are not intended to provide a full replacement in a written format.

Test Summary 1 Make Channel Tare/Calibration Connections

[a] Connect wiring to terminal block (see Figure 2-3)

[b] Connect terminal block to either the HP E1415A or E1419A

Note The procedure shown uses channel 07. Substitute the appropriate channel number and SCP number if you use another channel.

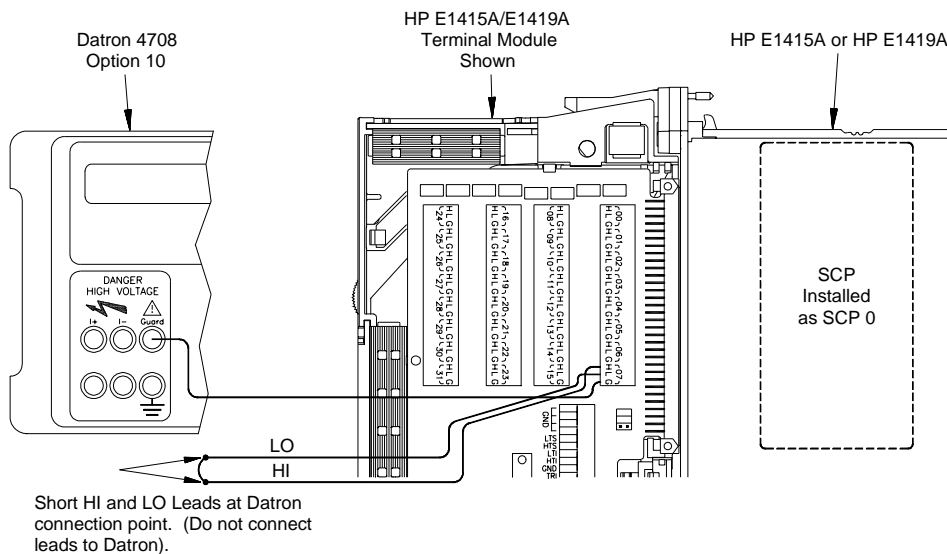

Figure 2-3. Channel Tare Calibration Connections

2 Check SCP 0 type (must be E1501A, E1502A or E1512A)

SYST:CTYP? (@107)
ENTER statement

*Check SCP 0 type
Returns SCP type*

3 Perform Channel Calibrations

CAL:TARE (@107)

*Compensate for voltage offsets
in wiring, plus executes *CAL?
command.*

CAL:ZERO?
ENTER statement

*Compensate for offset drift.
Wait for CAL:ZERO to complete*

4 Make Connections to DC Standard

WARNING

The DC Standard (Datron 4708, Option 10) can produce dangerous voltages that are present on the terminals. Do not touch the front (or rear) panel terminals unless you are sure no dangerous voltage is present.

[a] Connect HI and LO leads to DC Standard (see Figure 2-4)

[b] Set DC Standard OUTPUT to -50 mV

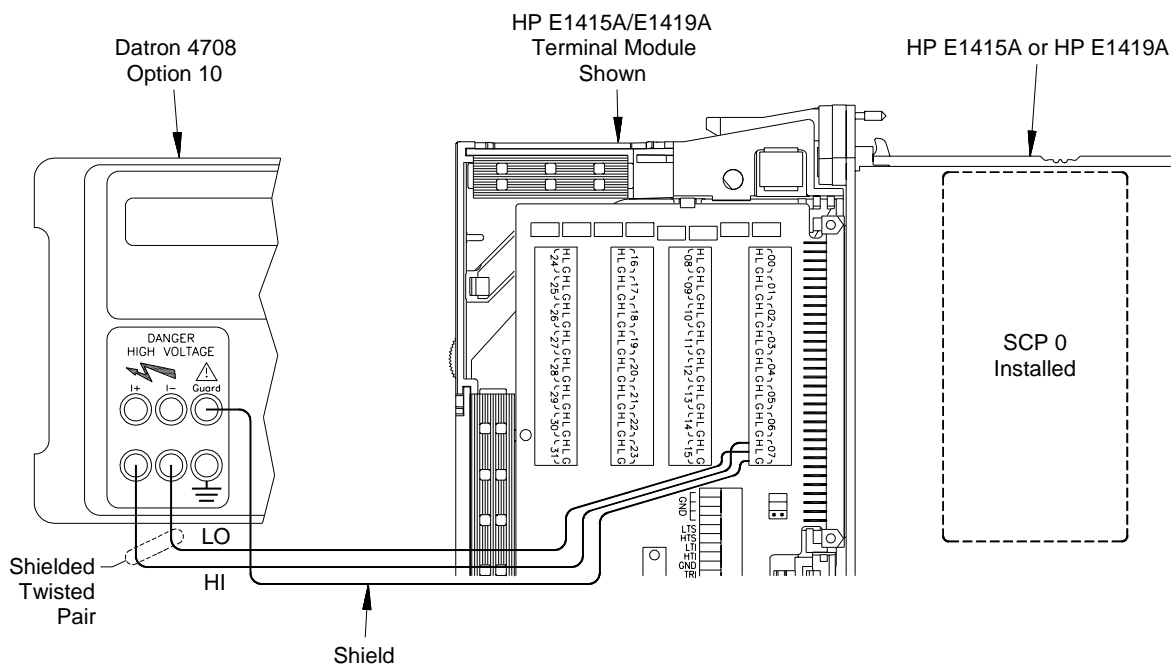

Figure 2-4. DC Standard Connections

5 Configure for DCV Measurements

*RST;*CLS;*OPC?

*Reset module, clear status
register*

ENTER statement

**OPC? return*

TRIG:SOUR TIM	<i>Configure trigger system</i>
TRIG:TIM 1e-3	<i>Set trigger intervals</i>
ARM:SOUR IMM	<i>Configure ARM system</i>
TRIG:COUN 400	<i>Set number of times to trigger</i>
SAMP:TIM 1e-4	<i>Set time between channels</i>
ALG:DEF <algorithm>	<i>Define algorithm</i>

6 Make DCV Measurements

FUNC:VOLT .0625, (@107)	<i>Set DCV meas, .0625V range on ch 07</i>
INIT:IMM	<i>Initiate measurement</i>
DATA:FIFO:PART? 400	<i>Returns 400 readings from FIFO buffer</i>
ENTER statement	<i>Enters 400 readings</i>
Average = SUM(Result)/400.0	<i>Result is average of 400 readings</i>

7 Repeat Measurements for each Input and Range

[a] Set DC Standard OUTPUT to -37 mV and repeat Step 6

[b] Repeat [a] for the inputs and ranges in the following table

Controller Range	.0625 V	.25 V	1.0 V	4.0 V	16.0 V
Input (Vdc)	-0.050	-0.20	-0.80	-3.2	-12.8
	-0.037	-0.15	-0.60	-2.4	-9.6
	-0.025	-0.10	-0.40	-1.6	-6.4
	-0.012	-0.05	-0.20	-0.8	-3.2
	0.000	0.00	0.00	0.0	0.0
	0.012	0.05	0.20	0.8	3.2
	0.025	0.10	0.40	1.6	6.4
	0.037	0.15	0.60	2.4	9.6
	0.050	0.20	0.80	3.2	12.8

E1501A, E1502A and E1512A Verification Test Programs

To test the E1501A, run the "PERF01" program. To test the E1502A or E1512A, run the "PERF02_12" program. Typical results for Tests 2-1 and 2-2 follow.

Test 2-1: DCV Accuracy - E1501A (PERF01) Typical Results

HP E1415A and HP E1419A
DC Voltage Accuracy Test
E1501A Straight-Through SCP

Range	Input	Minimum	Reading	Maximum
.0625 V	-50.0000 mV	-50.0103 mV	-50.0071 mV	-49.9897 mV
.0625 V	-37.0000 mV	-37.0090 mV	-37.0063 mV	-36.9910 mV
.
.
16.0 V	+12.8000 V	+12.7982 V	+12.8001 V	+12.8018 V

Test 2-2: DCV Accuracy - E1502A or E1512A (PERF02_12) Typical Results

HP E1415A and HP E1419A
DC Voltage Accuracy Test
E1502A or E1512A Fixed Filter SCP

Range	Input	Minimum	Reading	Maximum
.0625 V	-50.0000 mV	-50.0122 mV	-50.0046 mV	-49.9878 mV
.0625 V	-37.0000 mV	-37.0109 mV	-37.0049 mV	-36.9891 mV
.
.
16.0 V	+12.8000 V	+12.7982 V	+12.8001 V	+12.8018 V

Test 2-3: DCV Accuracy - E1503A (Gain X1)
Test 2-4: DCV Accuracy - E1503A (Gain X8)
Test 2-5: DCV Accuracy - E1503A (Gain X64)

Test Program Description These three tests (test program PERF0301.C, PERF0308 and PERF0364) check DC Voltage measurement accuracy with an E1503A Amplifier+Filter SCP. Test 2-3 uses gain X1, Test 2-4 uses gain X8, and Test 2-5 uses gain X64.

Note View complete performance verification test procedures by opening the SCP test program source file in any standard word processor (e.g., MS WORD, WordPad, Notepad, etc.). You can print a hard copy version to view along with this chapter. The test descriptions provided in this chapter are simply "summaries" which supplement the test set-up diagrams. These test summaries support the test programs but are not intended to provide a full replacement in a written format.

Test Summary 1 Make Channel Tare/Calibration Connections

- [a] Connect wiring to terminal block (see Figure 2-5)
- [b] Connect terminal block to installed HP E1415A or E1419A

Note The procedure shown uses channel 07, gain X1, and 100 Hz filter cutoff frequency. Substitute the appropriate channel number, gain, and filter cutoff frequency as required for your application..

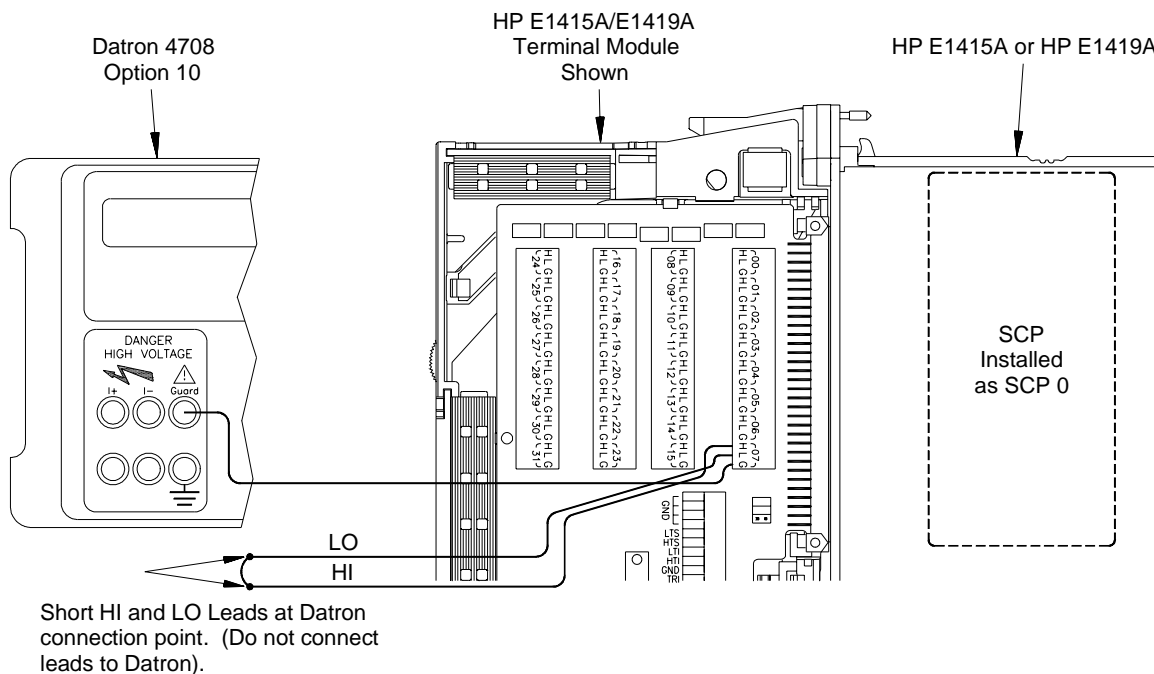

Figure 2-5. Channel Tare/Calibration Connections

2 Check SCP 0 type (must be E1503A); Set Gain and Filter

```

SYST:CTYP? (@107)
ENTER statement
*RST;*CLS;*OPC?
ENTER statement
INP:GAIN 1, (@107)
INP:FILT:FREQ 100, (@107)
    
```

Check SCP 0 type
Returns SCP type
Reset module, clear status reg
*Verify *OPC? completion*
Set SCP gain X1
Set 100 Hz as filter cutoff freq

3 Perform Channel Calibrations

```

CAL:TARE (@107)

CAL:ZERO?
ENTER statement
    
```

Compensate for voltage offsets
*in wiring, plus executes *CAL?.*
Compensate for offset drift.
Wait for CAL:ZERO to complete

4 Make Connections to DC Standard

WARNING

The DC Standard (Datron 4708, Option 10) can produce dangerous voltages that are present on the terminals. Do not touch the front (or rear) panel terminals unless you are sure no dangerous voltage is present.

[a] Connect HI and LO leads to DC Standard (see Figure 2-6)

[b] Set DC Standard OUTPUT to -50 mV

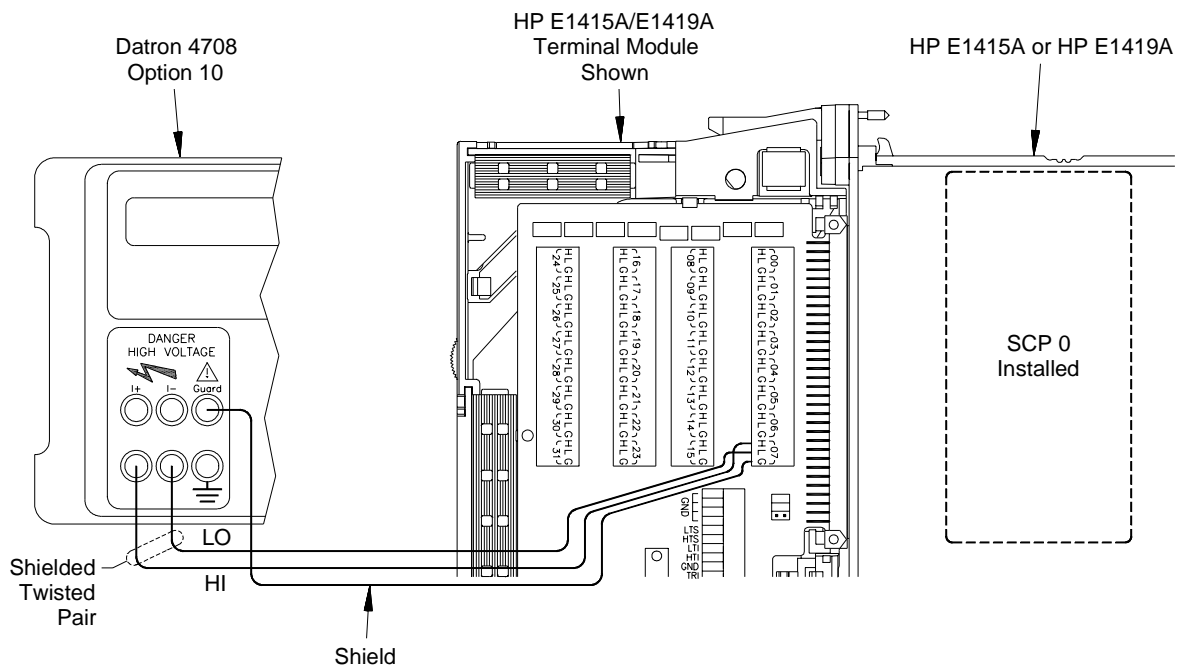

Figure 2-6. DC Standard Connections

5 Make DCV Measurements

ALG:DEF <algorithm>
 FUNC:VOLT .0625, (@107)

*Define algorithm
 Set DCV meas, .0625V range on
 ch 07*

TRIG:SOUR TIM
 TRIG:TIM 1E-3
 TRIG:COUN 400
 SAMP:TIM 1E-4

*Sets triggering to timer
 Set trigger timing
 Set trigger count
 Pace measurements at 0.1 msec
 intervals*

CAL:ZERO?
 ENTER statement
 INIT:IMM
 DATA:FIFO:PART? 400

*Auto zero measurement
 Wait for CAL:ZERO to complete
 Sets Wait for Trigger state
 Returns 400 readings from
 FIFO buffer*

ENTER Statement
 INIT:CONT OFF

*Enters 400 readings
 Finish scan, return to Trigger
 Idle state*

Average = SUM(Result)/400.0

*Result is average of 400
 readings*

6 Repeat measurements for each input and range

[a] Set DC Standard OUTPUT to -37 mV and repeat Step 5
 (except for *RST;*CLS;*OPC?)

[b] Repeat [a] for the inputs and ranges in the following table

Controller Range	.0625V	.25V	1.0V	4.0V	16.0V
SCP Gain X1 (Test 2-3)	-50 mV	-0.20 V	-0.80 V	-3.2 V	-12.8 V
	-37 mV	-0.15 V	-0.60 V	-2.4 V	- 9.6 V
	-25 mV	-0.10 V	-0.40 V	-1.6 V	- 6.4 V
	-12 mV	-0.05 V	-0.20 V	-0.8 V	- 3.2 V
	0 mV	0.00 V	0.00 V	0.0 V	0.0 V
	12 mV	0.05 V	0.20 V	0.8 V	3.2 V
	25 mV	0.10 V	0.40 V	1.6 V	6.4 V
	37 mV	0.15 V	0.60 V	2.4 V	9.6 V
	50 mV	0.20 V	0.80 V	3.2 V	12.8 V
SCP Gain X8 (Test 2-4)	-6.0 mV	-25 mV	-100 mV	-0.4 V	-1.6 V
	-4.5 mV	-18 mV	- 75 mV	-0.3 V	-1.2 V
	-3.0 mV	-12 mV	- 50 mV	-0.2 V	-0.8 V
	-1.5 mV	- 6 mV	- 25 mV	-0.1 V	-0.4 V
	0.0 mV	0 mV	0 mV	0.0 V	0.0 V
	1.5 mV	6 mV	25 mV	0.1 V	0.4 V
	3.0 mV	12 mV	50 mV	0.2 V	0.8 V
	4.5 mV	18 mV	75 mV	0.3 V	1.2 V
	25 mV	100 mV	0.4 V	1.6 V	

SCP Gain X64 (Test 2-5)	N/A	-3.0 mV	-12.8 mV	-50.0 mV	-200 V
		-2.5 mV	- 9.6 mV	-37.5 mV	-150 V
		-1.5 mV	- 6.4 mV	-25.0 mV	-100 V
		-0.8 mV	- 3.2 mV	-12.5 mV	- 50 V
		0.0 mV	0.0 mV	0.0 mV	0 V
		0.8 mV	3.2 mV	12.5 mV	50 V
		1.5 mV	6.4 mV	25.0 mV	100 V
		2.5 mV	9.6 mV	37.5 mV	150 V
		3.0 mV	12.8 mV	50.0 mV	200 V

E1503A Verification Test Programs

To perform Test 2-3, run the "PERF0301" program. To perform Test 2-4, run the "PERF0308" program. To perform Test 2-5, run the "PERF0364" program. Typical results for the "PERF0301", "PERF0308" and "PERF0364" programs (all with 100 Hz filter) follow.

Note

There are 14 performance verification tests available for the E1503A SCP. You may do any or all tests, depending on your specific application requirements. The E1503A SCP was factory-tested at 2 Hz, 10 Hz, 100 Hz and filter OFF for gain X1; at 100 Hz for gain X8; and at 100 Hz for gain X64.

Test 2-3: DCV Accuracy - E1503A (Gain X1) (PERF0301) Typical Results

HP E1415A or HP E1419A
DC Voltage Accuracy Test
E1503A Amplifier+Filter SCP
Gain X1 and 100 Hz Filter

Range	Input	Minimum	Reading	Maximum
.0625 V	-50.0000 mV	-50.0118 mV	-50.0032 mV	-49.9882 mV
.0625 V	-37.0000 mV	-37.0105 mV	-37.0035 mV	-36.9895 mV
.
.
16.0 V	+12.8000 V	+12.7982 V	+12.7997 V	+12.8018 V

Test 2-4: DCV Accuracy - E1503A (Gain X8) (PERF0308) Typical Results

HP E1415A or HP E1419A
DC Voltage Accuracy Test
E1503A Amplifier+Filter SCP
Gain X8 and 100 Hz Filter

Range	Input	Minimum	Reading	Maximum
.0625 V	-6.0000 mV	-6.0044 mV	-6.0010 mV	-5.9956 mV
.0625 V	-4.5000 mV	-4.5043 mV	-4.5029 mV	-4.4953 mV
.
.
16.0 V	+1.6000 V	+1.5998 V	+1.6001 V	+1.6002 V

Test 2-5: DCV Accuracy - E1503A (Gain X64) (PERF0364) Typical Results

HP E1415A or HP E1419A
DC Voltage Accuracy Test
E1503A Amplifier+Filter SCP
Gain X64 and 100 Hz Filter

Range	Input	Minimum	Reading	Maximum
.25 V	-3.0000 mV	-3.0024 mV	-3.0019 mV	-2.9976 mV
.25 V	-2.5000 mV	-2.5024 mV	-2.5016 mV	-2.4977 mV
.
.
16 V	+200.0000 mV	+199.972 mV	+200.0024 mV	+200.028 mV

Test 2-6: DCI Accuracy - E1505A

Test Program Description Test 2-6 (test program PERF05.C) checks DC current output accuracy when an E1505A Current Source SCP is used.

Note View complete performance verification test procedures by opening the SCP test program source file in any standard word processor (e.g., MS WORD, WordPad, Notepad, etc.). You can print a hard copy version to view along with this chapter. The test descriptions provided in this chapter are simply "summaries" which supplement the test set-up diagrams. These test summaries support the test programs but are not intended to provide a full replacement in a written format.

Test Summary 1 Make Channel Connections

- [a] Connect wiring to terminal block and DMM (see Figure 2-7)
- [b] Connect the terminal block to the installed HP E1415A or E1419A
- [c] Connect an HP-IB cable from the DMM to the computer

Note The procedure shown uses channel 00. Substitute the appropriate channel number as required for your application. Using shielded, teflon-coated cable for connections is highly recommended.

NOTE: The E1415/19 has a negative current source. Connect the channel H terminal to the DMM LO. Connect the channel L terminal to the DMM "I" terminal to read positive current.

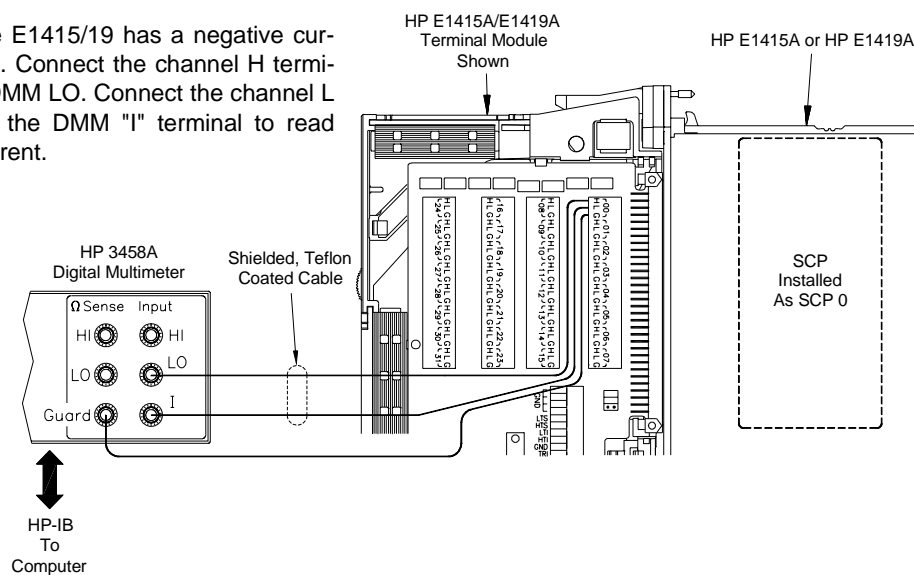

Figure 2-7. Typical Wiring Configurations

2 Check SCP 0 type (must be E1505A)

SYST:CTYP? (@100)
ENTER statement

*Check SCP 0 type
Returns SCP type*

3 Perform HP 3458A DMM Autocalibration (Optional)

For most accurate results, an autocalibration (ACAL) of the HP 3458A DMM is recommended every 24 hours. (The autocalibration takes about 12 minutes.) As required, perform an autocalibration with the following command. If autocalibration is not required, go to step 4.

OUTPUT 722;"ACAL ALL" *Performs HP 3458A DMM autocalibration*

4 Perform Channel Calibration (30 μ A range)

Note It is essential to perform a channel calibration (*CAL?) for each current range before measuring the current output on the range. For example, you must set the module for DCI operation on the 30 μ A range and perform *CAL? for the 30 μ A range before measuring the 30 μ A output. The same procedure is required for the 488 μ A range.

OUTP:CURR:STAT ON, (@100) *Enable current output on channel 00*
OUTP:CURR:AMPL 30E-6, (@100) *Set output current on ch 00 to 30 μ A*
*CAL? *Perform *CAL?*
ENTER statement *Return *CAL? result*
CAL:ZERO? *Perform Controller Zero*
ENTER statement *Return CAL:ZERO result*

5 Make DCI Measurement (30 μ A range)

OUTPUT 722;"PRESET NORM" *Set HP 3458A DMM @ address 722 to known state*
OUTPUT 722;"NPLC 100" *Set HP 3458A DMM to NPLC 100*
OUTPUT 722;"DCI 100E-6" *Set DMM range to DCI @ 100 μ A*
WAIT 5 *Wait 5 sec for settling*
ENTER statement *Return DCI reading (~30.518 μ A)*

6 Perform Channel Calibration (488 μ A range)

OUTP:CURR:STAT ON, (@100) *Enable current output on channel 00*
OUTP:CURR:AMPL 488E-6, (@100) *Set output current on ch 00 to 488 μ A*
*CAL? *Perform *CAL?*
ENTER statement *Return *CAL? result*
CAL:ZERO? *Perform Controller Zero*
ENTER statement *Return CAL>ZERO? result*

7 Make DCI Measurement (488 μ A range)

OUTPUT 722;"PRESET NORM" *Set HP 3458A DMM @ address 722 to known state*
OUTPUT 722;"NPLC 100" *Set HP 3458A DMM to NPLC 100*

OUTPUT 722;"DCI 1E-3"
WAIT 5
ENTER statement

*Set DMM range to DCI @ 1 mA
Wait 5 sec for settling
Return DCI reading (~488.28
uA)*

E1505A Verification Test Program

To perform Test 2-6, run the "PERF05" program. Typical results for the "PERF05" program follow.

Test 2-6: DCI Accuracy - E1505A (PERF05) Typical Results

HP E1415A or HP E1419A DC Current Accuracy Test E1505A Current Source SCP			
Current (μ A)	Minimum (μ A)	Reading (μ A)	Maximum (μ A)
30.518	30.509	30.521	30.527
488.28	488.22	488.29	488.34

Test 2-7: Excitation Voltage Accuracy - E1506A

Test 2-8: Excitation Voltage Accuracy - E1507A

Test Program Description

These two tests (test program PERF06_07.C) check SCP excitation voltage accuracy. Test 2-7 uses an E1506A 120Ω Strain Gage SCP and Test 2-8 uses an E1507A 350Ω Strain Gage SCP. An HP 3458A DMM is used to measure the excitation voltage for each SCP.

Note

View complete performance verification test procedures by opening the SCP test program source file in any standard word processor (e.g., MS WORD, WordPad, Notepad, etc.). You can print a hard copy version to view along with this chapter. The test descriptions provided in this chapter are simply "summaries" which supplement the test set-up diagrams. These test summaries support the test programs but are not intended to provide a full replacement in a written format.

Test Summary 1 Make Channel Connections

- [a] Connect wiring to terminal block and DMM (see Figure 2-8)
- [b] Connect the terminal block to the installed HP E1415A or E1419A
- [c] Connect an HP-IB cable from the DMM to the computer

Note

This procedure shown uses channel 06. Substitute the appropriate channel number as required for your application. Connections are shown to channel 06 (+E and -E for SCP 0). Modify the connections as required for the channel you use.

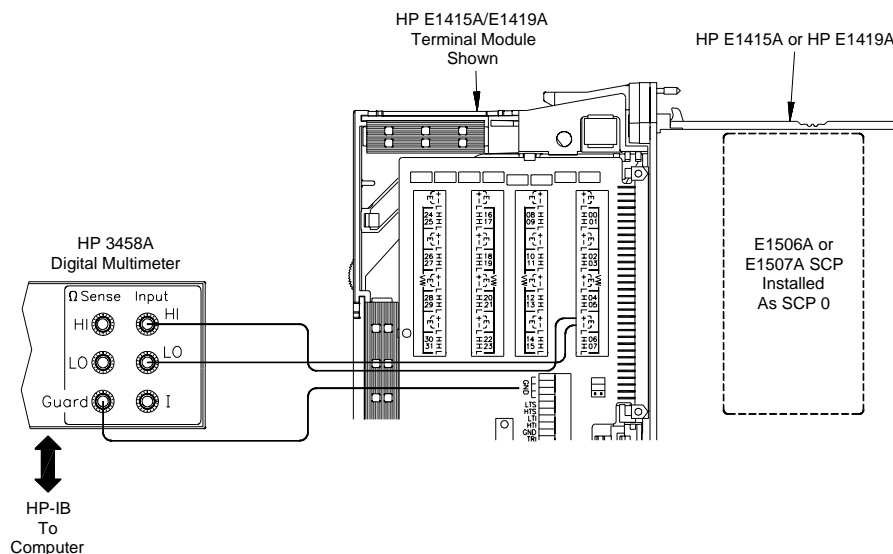

Figure 2-8. Typical Wiring Configuration

2 Check SCP 0 Type (must be E1506A or E1507A)

SYST:CTYP? (@106) *Check SCP 0 type*
ENTER statement *Returns SCP type*

3 Perform HP 3458A DMM Autocalibration (Optional)

For most accurate results, an autocalibration (ACAL) of the HP 3458A DMM is recommended every 24 hours. (The autocalibration takes about 12 minutes.) As required, perform an autocalibration with the following command. If autocalibration is not required, go to Step 4.

OUTPUT 722;"ACAL ALL" *HP 3458A DMM
autocalibration*

4 Perform Channel Calibration

*RST;*CLS;*OPC? *Reset module, clear status
registers, wait for completion*
ENTER statement *Return *OPC? completion*
*CAL? *Perform *CAL?*
ENTER statement *Return *CAL? result*
CAL:ZERO? *Perform Controller Zero*
ENTER statement *Return CAL:ZERO result*

5 Measure Excitation Voltage

OUTPUT 722;"PRESET NORM" *Set HP 3458A DMM @ address
722 to known state*
OUTPUT 722;"NPLC 100" *Set HP 3458A DMM to NPLC
100*
ENTER statement *Return Excitation Voltage (~3.9
Vdc)*

E1506A and E1507A Verification Test Program

To perform Test 2-7 or Test 2-8, run the "PERF06_07" program. Typical results for the "PERF06_07" program follows.

Test 2-7: Excitation Voltage Accuracy - E1506A (PERF06_07) Typical Results

HP E1415A or HP E1419A Excitation Voltage Accuracy Test E1506A Strain Gage SCP		
Minimum	Measured	Maximum
3.899488 Vdc	3.900027 Vdc	3.900512 Vdc

Test 2-8: Excitation Voltage Accuracy - E1507A (PERF06_07) Typical Results

HP E1415A or HP E1419A Excitation Voltage Accuracy Test E1507A Strain Gage SCP		
Minimum	Measured	Maximum
3.899488 Vdc	3.900068 Vdc	3.900512 Vdc

Test 2-9: DCV Accuracy - E1508A

Test 2-10: DCV Accuracy - E1509A

Test Program Description Test 2-9 (test program PERF08.C) checks DC voltage measurement accuracy when an E1508A Fixed Filter+Amplifier SCP is used. Test 2-10 (test program PERF09.C) checks DC voltage measurement accuracy when an E1509A Fixed Filter+Amplifier SCP is used.

Note View complete performance verification test procedures by opening the SCP test program source file in any standard word processor (e.g., MS WORD, WordPad, Notepad, etc.). You can print a hard copy version to view along with this chapter. The test descriptions provided in this chapter are simply "summaries" which supplement the test set-up diagrams. These test summaries support the test programs but are not intended to provide a full replacement in a written format.

Test Summary 1 Make Channel Tare/Calibration Connections

[a] Connect wiring to terminal block (see Figure 2-9)

[b] Connect terminal block to installed HP E1415A or E1419A

Note The procedure shown uses channel 07. Substitute the appropriate channel number and SCP number if you use another channel.

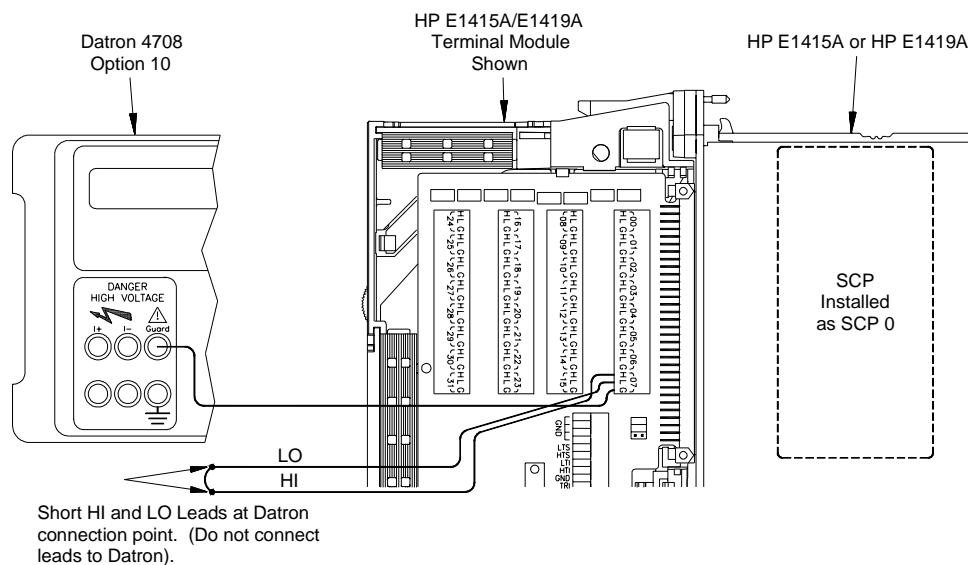

Figure 2-9. Channel Tare/Calibration Connections

2 Check SCP 0 type (must be E1508A or E1509A)

SYST:CTYP? (@107)
ENTER statement

*Check SCP 0 type
Returns SCP type*

3 Perform Channel Calibrations

CAL:TARE

Perform channel calibration

4 Make Connections to DC Standard

WARNING

The DC Standard (Datron 4708, Option 10) can produce dangerous voltages that are present on the terminals. Do not touch the front (or rear) panel terminals unless you are sure no dangerous voltage is present.

[a] Connect HI and LO leads to DC Standard (see Figure 2-10)

[b] Set DC Standard OUTPUT to -3 mV

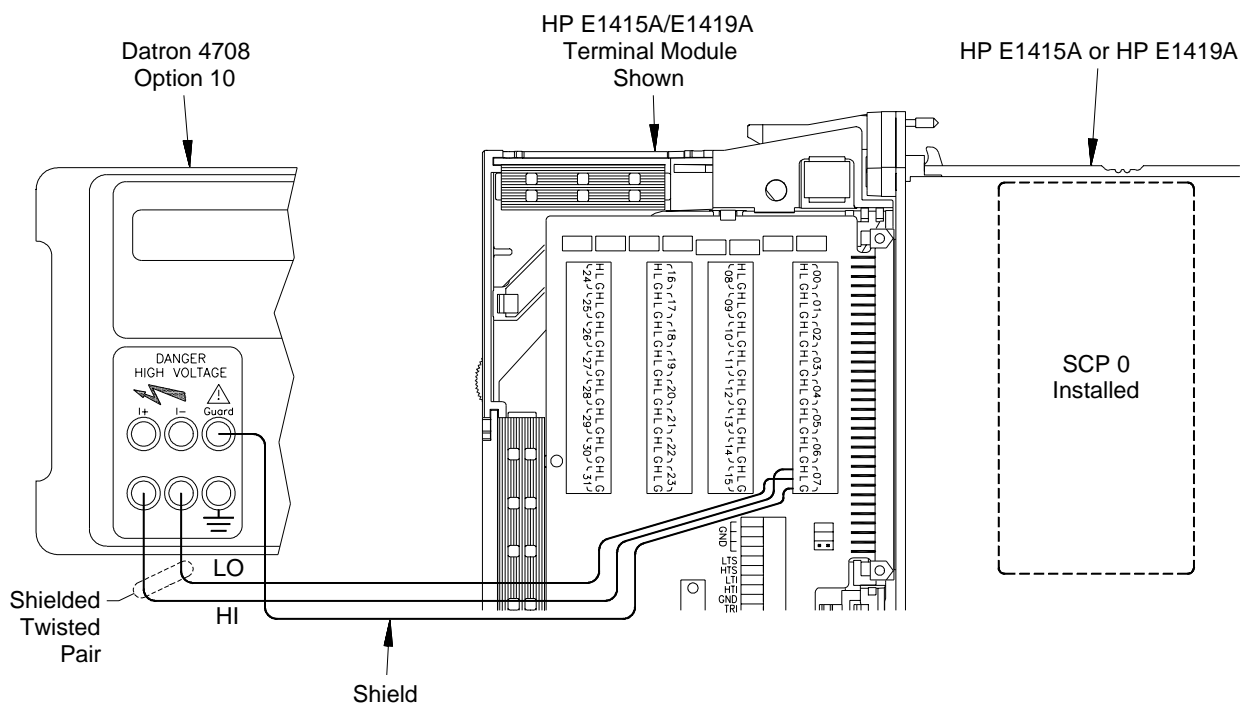

Figure 2-10. DC Standard Connections

5 Make DCV Measurements

*RST;*CLS;*OPC?

Reset module, clear status register

ENTER statement
FUNC:VOLT .0625, (@107)

**OPC? return
Set DCV meas, .0625V range on ch 07*

TRIG:SOUR TIM
TRIG:TIM 1E-3

*Sets triggering to timer
Set trigger time interval*

SAMP:TIM 1E-4

Pace measurements at 0.1 msec intervals

ALG:DEF <algorithm>

Define algorithm

CAL:ZERO?

Auto zero measurement

ENTER statement

Wait for CAL:ZERO to complete

INIT:IMM

Sets Wait for Trigger state

DATA:FIFO:PART? 400

Returns 400 readings from FIFO buffer

ENTER Statement

Enters 400 readings

Average = SUM(Result)/400.0

Result is average of 400 readings

6 Repeat Measurements for each input and range

[a] Set DC Standard OUTPUT to -2.3 mV and repeat Step 5 (except for *RST;*CLS;*OPC?)

[b] Repeat [a] for the inputs and ranges in the following table

Controller Range	.0625 V	.25 V	1.0 V	4.0 V	16.0 V*
Input (mV)	-3.0	-13	-50	-200	-800
	-2.3	-9	-38	-150	-600
	-1.5	-6	-25	-100	-400
	-0.8	-3	-13	-50	-200
	0	0	0	0	0
	0.8	3	13	50	200
	1.5	6	25	100	400
	2.3	9	38	150	600
	3.0	13	50	200	800

* Range applies to Test 2-9 (E1508A SCP) ONLY

E1508A and E1509A Verification Test Programs

To perform Test 2-9, run the "PERF08" program. To perform Test 2-10, run the "PERF09" program. Typical results for Test 2-9 and Test 2-10 follow.

Test 2-9: DCV Accuracy - E1508A (PERF08) Typical Results

HP E1415A or HP E1419A DC Voltage Accuracy Test E1508A Fixed Filter+Amplifier SCP				
Range	Input	Minimum	Reading	Maximum
.0625 V	-3.0 mV	-3.0041 mV	-3.0028 mV	-2.9959 mV
.0625 V	-2.3 mV	-2.3040 mV	-2.3034 mV	-2.2960 mV
.
16.0 V	+800.0 mV	+799.889 mV	+800.0083 mV	+800.111 mV

Test 2-10: DCV Accuracy - E1509A (PERF09) Typical Results

HP E1415A or HP E1419A DC Voltage Accuracy Test E1509A Fixed Filter+Amplifier SCP				
Range	Input	Minimum	Reading	Maximum
.25 V	-3.0 mV	-3.0026 mV	-2.9980 mV	-2.9974 mV
.25 V	-2.3 mV	-2.3025 mV	-2.3001 mV	-2.2975 mV
.
16 V	+200.0 mV	+199.972mV	+200.0287 mV	+200.028 mV

Test 2-11: Sample&Hold DCV Accuracy and Droop - E1510A

Test 2-12: Sample&Hold DCV Accuracy and Droop - E1511A

Test Program Description Test 2-11 (test program PERF10SH.C) checks the DC Voltage accuracy and Sample & Hold Droop for the four Sample & Hold channels (00 - 03; 08 - 11; etc) on the E1510A 4-Channel Sample & Hold Signal Conditioning SCP. Test 2-12 (test program PERF11.C) checks the DC Voltage accuracy and Sample & Hold Droop for the four Bridge Sense channels on an E1511A Transient Strain SCP.

Note The E1511A Transient Strain SCP should have all four channels configured for full-bridge measurements for proper calibration.

To test the 4 Straight-Through channels on the E1510A 4-Channel Sample & Hold Signal Conditioning SCP, use Test 2-13. To test the Excitation voltages on an E1511A Transient Strain SCP, use Test 2-14.

Note View complete performance verification test procedures by opening the SCP test program source file in any standard word processor (e.g., MS WORD, WordPad, Notepad, etc.). You can print a hard copy version to view along with this chapter. The test descriptions provided in this chapter are simply "summaries" which supplement the test set-up diagrams. These test summaries support the test programs but are not intended to provide a full replacement in a written format.

Test Summary 1 Make Channel Tare/Calibration Connections

[a] Connect wiring to Terminal Module (see Figure 2-11).

[b] Connect Terminal Module to installed HP E1415A or E1419A.

Note The example shown uses channel 02. Substitute the appropriate channel number and SCP number if you use another channel.

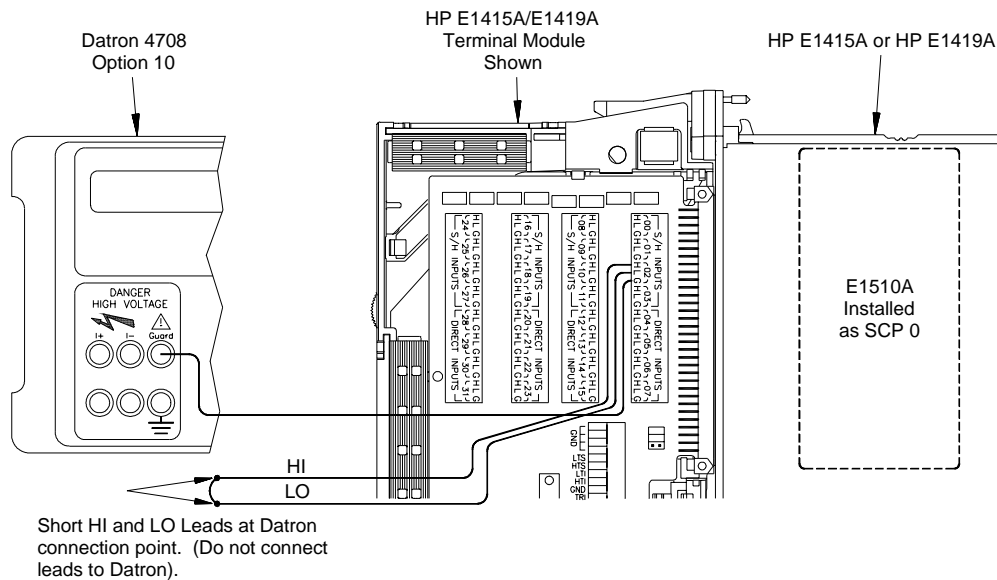

Figure 2-11. Channel Tare/Calibration Connections

2 Check SCP 0 type (must be E1510A); Set Gain and Filter

SYST:CTYP? (@102)	<i>Check SCP 0 type</i>
ENTER statement	<i>Returns SCP type</i>
INP:FILT:FREQ 15,(@102)	<i>Enables 15 Hz filter on S&H channels</i>
INP:GAIN 0.5,(@102)	<i>Sets gain to 0.5 on S&H channels</i>

3 Perform Channel Calibrations

CAL:TARE (@102)	<i>Perform channel calibration</i>
ENTER statement	<i>Return the *CAL? result</i>

4 Make Connections to DC Standard

WARNING The DC Standard (Datron 4708, Option 10) can produce dangerous voltages that are present on the terminals. Do not touch the front (or rear) panel terminals unless you are sure no dangerous voltage is present.

[a] Connect HI and LO leads to DC Standard (see Figure 2-12). (This test is only for the 4 Sample & Hold channels on an E1510A or E1511A.)

[b] Set DC Standard OUTPUT to -100 mV (first gain tested is X0.5).

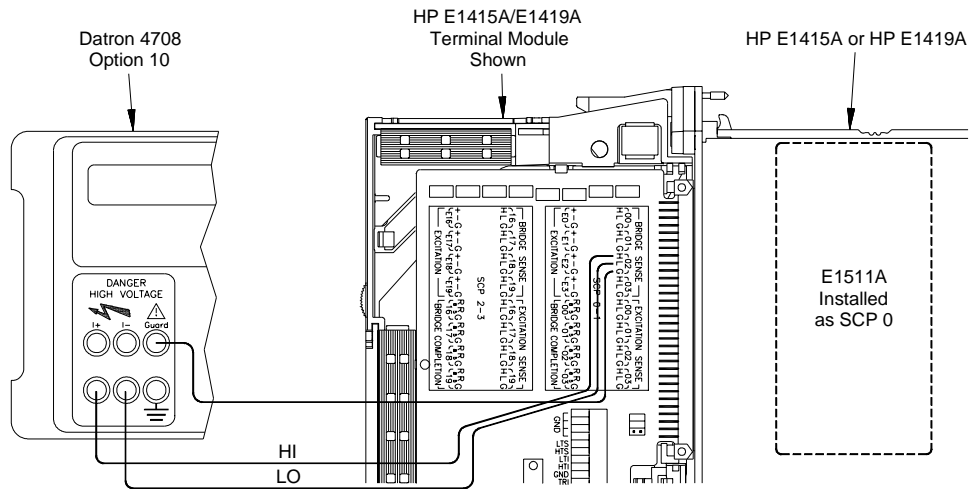

Figure 2-12. DC Standard Connections

5 Make DC Voltage Measurements

*RST;*CLS;*OPC?

ENTER statement
FUNC:VOLT .125, (@102)

TRIG:SOUR TIM
TRIG:TIM 1E-3
TRIG:COUN 400
SAMP:TIM 1E-4
ALG:DEF <algorithm>
CAL:ZERO?
ENTER statement
INIT:IMM
DATA:FIFO:PART? 1600

ENTER Statement

Average = SUM(Readings)/400.0

Reset module, clear status register

OPC? return

Set DCV meas, .125V range on ch 102

Sets trig source as internal timer

Set trigger timer

Set trigger count

Pace measurements at 0.1 mS

Define algorithm

Auto zero measurement

Wait for CAL:ZERO to complete

Sets Wait for Trigger state

Returns 1600 readings from

FIFO buffer

Enters 1600 readings (400 per ch)

Result is average of 400 rdgs/channel

6 Repeat Measurements for each gain, input, and range

[a] Set DC Standard OUTPUT to 0.0 V and repeat Step 5 (except reset)

[b] Repeat [a] for the inputs and ranges in the following table

Sample&Hold Channels Gain = X0.5	Controller Range	.0625	.25	1.0	4.0	
	Input (V)	-0.1 0.0 0.1	-0.4 0.0 0.4	-1.6 0.0 1.6	-6.4 0.0 6.4	
Sample&Hold Channels Gain = X8	Controller Range	.0625	.25	1.0	4.0	
	Input (V)	-0.00624 0.0 0.00624	-0.025 0.0 0.025	-0.1 0.0 0.1	-0.4 0.0 0.4	
Sample&Hold Channels Gain = X64	Controller Range		.25	1.0	4.0	
	Input (V)		-0.00312 0.0 0.00312	-0.0125 0.0 0.0125	-0.05 0.0 0.05	
Sample&Hold Channels Gain = X512	Controller Range				4.0	
	Input (V)				-0.00625 0.0 0.00625	
Straight-Through Channels	CONTROLLER RANGE	0.0625	0.25	1.0	4.0	16.0
	Input (V)	-0.05	-0.2	-0.8	-3.2	-12.8
		-0.037	-0.15	-0.6	-2.4	-9.6
		-0.025	-0.1	-0.4	-1.6	-6.4
		-0.012	-0.05	-0.2	0.8	-3.2
		0.00	0.0	0.0	0.0	0.0
		0.012	0.05	0.2	0.8	3.2
		0.025	0.1	0.4	1.6	6.4
		0.037	0.15	0.6	2.4	9.6
	0.05	0.2	0.8	3.2	12.8	

7 Set Up module for Sample & Hold Droop Test

INP:GAIN .5,(@102)	<i>Set gain to X0.5</i>
INP:FILT:LPAS:STATE ON,(@102)	<i>Filter on</i>
INP:FILT:FREQ 100,(@102)	<i>Filter Freq 100 Hz</i>
CAL:ZERO?	<i>Do Cal Zero on SCP</i>
ENTER statement	<i>Return CAL:ZERO response</i>
INP:FILT:LPAS:STATE OFF	<i>Turn filter off</i>
FUNC:VOLT 4,(@108,111)	<i>DCV meas, 4 V range</i>
TRIG:SOUR TIM	<i>Sets triggering to timer</i>
TRIG:TIM 1E-3	<i>Set trigger timing</i>
TRIG:COUN 100	<i>Set trigger count</i>
SAMP:TIM 1E-4	<i>Sets sample rate at 0.1 msec</i>
DATA:FIFO:RESET	<i>Clear FIFO buffer</i>
FORMAT ASCII	<i>Readings are ASCII format</i>
INIT:IMM	<i>Trigger the module</i>

DATA:FIFO:PART? 100
 ENTER statement
 Droop = (Max-Min)/1

Read back 100 readings
Enters 100 readings
Droop in Volts/Sec = (Start V -
*End V)/(Tsamp * NRDGS).*
*Note: Tsamp * NRDGS = 1 Sec*

**E1510A and E1511A
 Verification Test
 Programs**

To perform Test 2-11 on an E1510A Sample & Hold SCP, run the "PERF10SH" program. To perform Test 2-12 on an E1511A Transient Strain SCP, run the "PERF11" program. Typical Results for the program follow.

Test 2-11: DCV Accuracy and Sample&Hold Droop - E1510A (PERF10SH) Typical Results

HP E1415A or HP E1419A DC Voltage Accuracy Test E1510A 4-Channel Sample & Hold SCP Channel 102 set at gain = 64.0				
Range	Input	Minimum	Reading	Maximum
0.25000	-0.003120	-0.003136	-0.003125	-0.003104
0.25000	0.000000	-0.000015	-0.000014	0.000015
0.25000	0.003120	0.003104	0.003122	0.003136
1.0000	-0.012500	-0.012518	-0.012503	-0.012483
1.0000	0.000000	-0.000015	-0.000014	0.000015
.
.
.
4.0000	0.000000	-0.000015	-0.000013	0.000015
4.0000	0.050000	0.049975	0.050007	0.050025

Test 2-13: DCV Accuracy, Straight-Through Channels -- E1510A

Test Program Description Test 2-13 (test program PERF10ST.C) is functionally identical to Test 2-1 for the E1501A SCP. Refer to that test earlier in this chapter for more information.

Note View complete performance verification test procedures by opening the SCP test program source file in any standard word processor (e.g., MS WORD, WordPad, Notepad, etc.). You can print a hard copy version to view along with this chapter. The test descriptions provided in this chapter are simply "summaries" which supplement the test set-up diagrams. These test summaries support the test programs but are not intended to provide a full replacement in a written format.

Figure 2-13 shows how to connect the equipment for testing; channel 07 is shown as an example.

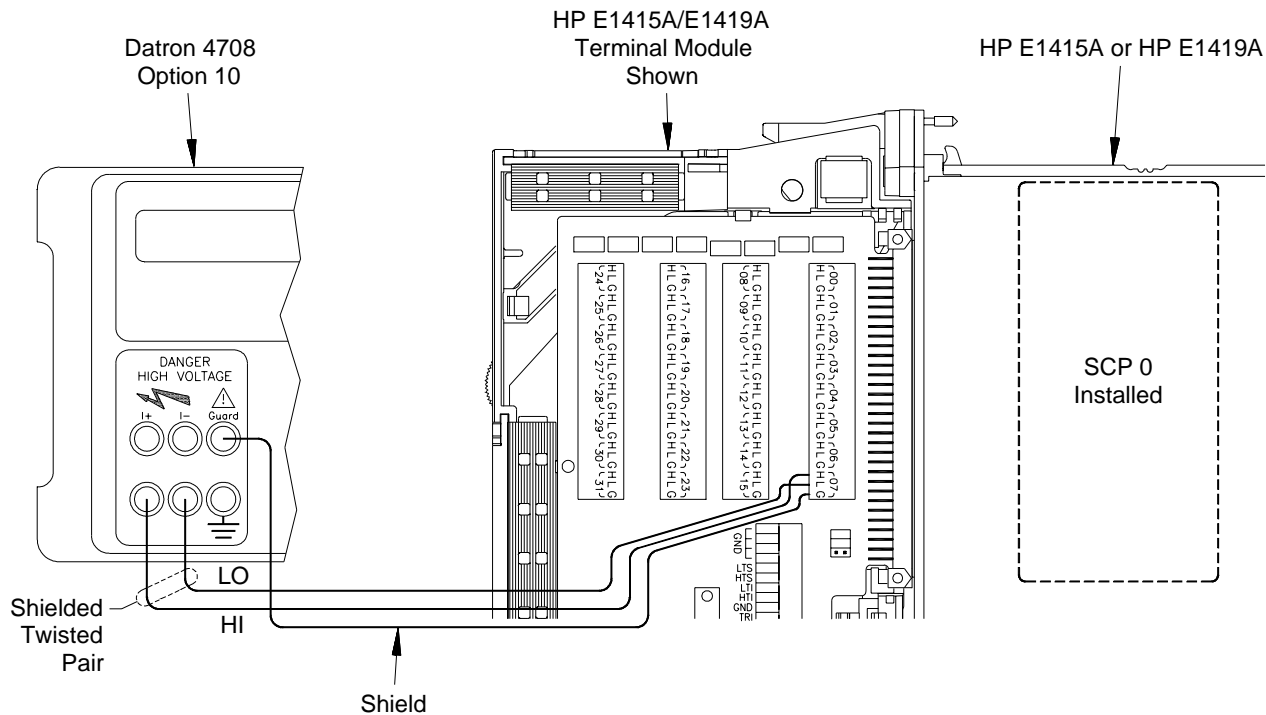

Figure 2-13. DC Standard Connections for the Straight-Through Channels

E1510A Verification Test Program

To perform Test 2-13 on the 4 straight-through channels (04 - 08; 12 - 15; etc.) of an E1510A Sample & Hold SCP, run the "PERF10ST" program. Use the program "PERF10SH" (Test 2-11) to test the 4 Sample & Hold channels.

Test 2-14: Excitation Voltage Measurement -- E1511A

Test Program Description

Test 2-14 (test program PERF11.C) checks the E1511A SCP excitation voltages. Voltage values are: 0 (off), 1, 2, 5, and 10 volts. There are no specifications for these voltages; the test uses an HP 3458A DMM to measure the excitation voltage.

Note

View complete performance verification test procedures by opening the SCP test program source file in any standard word processor (e.g., MS WORD, WordPad, Notepad, etc.). You can print a hard copy version to view along with this chapter. The test descriptions provided in this chapter are simply "summaries" which supplement the test set-up diagrams. These test summaries support the test programs but are not intended to provide a full replacement in a written format.

Test Summary 1 Make Channel Connections

- [a] Connect wiring to terminal module and DMM (see Figure 2-14)
- [b] Connect the terminal module to the installed HP E1415A or E1419A
- [c] Connect an HP-IB cable from the DMM to the computer

Note

This example shown uses channel 102. Substitute the appropriate channel number as required for your application. Connections are shown to channel 02 (E2+ and E2- for SCP 0/1). Modify the connections as required for the channel you use.

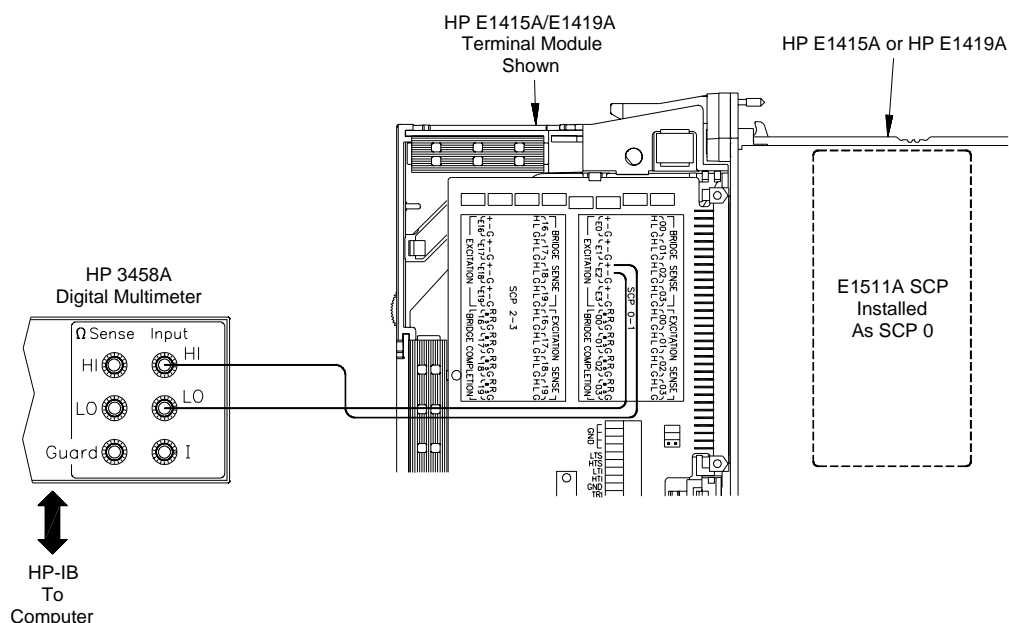

Figure 2-14. Typical Wiring Configuration

2 Check SCP 0 Type (must be E1511A)

SYST:CTYP? (@102) *Check SCP 0 type*
ENTER statement *Returns SCP type*

3 Perform HP 3458A DMM Autocalibration (Optional)

For most accurate results, an autocalibration (ACAL) of the HP 3458A DMM is recommended every 24 hours. (The autocalibration takes about 12 minutes.) As required, perform an autocalibration with the following command. If autocalibration is not required, go to Step 4.

OUTPUT 722; "ACAL ALL" *HP 3458A DMM autocalibration*

4 Set Excitation Voltages

OUTP:VOLT:AMPL 1,(@102,102,102) *Set excitation voltage to 1 volt on channel 102*

5 Measure Excitation Voltages

OUTPUT 722;"PRESET NORM" *Set HP 3458A DMM @ address 722 to known state*
OUTPUT 722;"NPLC 10" *Set HP 3458A DMM to NPLC 10*
ENTER statement *Return Excitation Voltage (~1.0 Vdc)*

6 Repeat Measurements for each excitation voltage

[a] Set the excitation voltage to 2, 5, and 10 volts and repeat Step 5

E1511A Verification Test Program

To perform Test 2-14 on an E1511A, run the program "PERF11". This program also tests the DCV accuracy and Sample&Hold droop on the Bridge Sense channels.

Test 2-15: DCV Accuracy -- E1512A

Test Program Description Test 2-15 (test program PERF02_12.C) is functionally identical to Test 2-2 for the E1502A SCP. Refer to Test 2-2 earlier in this chapter for more information.

Note View complete performance verification test procedures by opening the SCP test program source file in any standard word processor (e.g., MS WORD, WordPad, Notepad, etc.). You can print a hard copy version to view along with this chapter. The test descriptions provided in this chapter are simply "summaries" which supplement the test set-up diagrams. These test summaries support the test programs but are not intended to provide a full replacement in a written format.

E1512A Verification Test Program To perform Test 2-15 on the E1512A SCP, run the "PERF02_12" program.

Test 2-16: DCV Accuracy - E1513A

Test Program Description Test 2-16 (test program PERF13.C) checks HP E1415A or HP E1419A DC voltage measurement accuracy when an E1513A Divide by 16 SCP is used.

Note View complete performance verification test procedures by opening the SCP test program source file in any standard word processor (e.g., MS WORD, WordPad, Notepad, etc.). You can print a hard copy version to view along with this chapter. The test descriptions provided in this chapter are simply "summaries" which supplement the test set-up diagrams. These test summaries support the test programs but are not intended to provide a full replacement in a written format.

Test Summary 1 Make Channel Tare/Calibration Connections

[a] Connect wiring to terminal block (see Figure 2-15)

[b] Connect terminal block to installed HP E1415A or E1419A

Note The procedure shown uses channel 07. Substitute the appropriate channel number and SCP number if you use another channel.

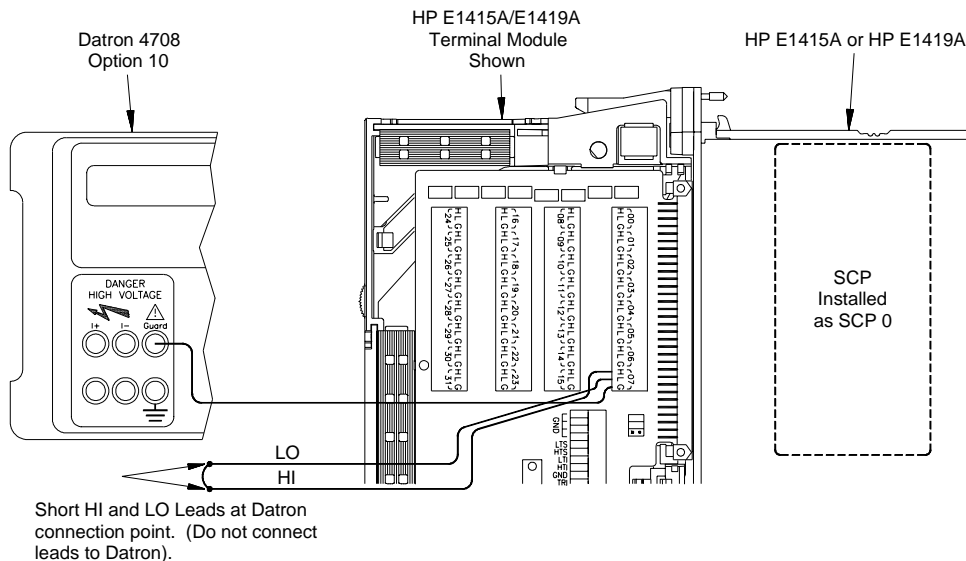

Figure 2-15. Channel Tare/Calibration Connections

2 Check SCP 0 type (must be E1513A)

SYST:CTYP? (@107)
ENTER statement

*Check SCP 0 type
Returns SCP type*

3 Perform Channel Calibrations

CAL:TARE (@107)

*Perform cal tare
Perform channel calibration
Auto zero measurement
Wait for CAL:ZERO to*

CAL:ZERO?

ENTER statement

4 Make Connections to DC Standard

WARNING

The DC Standard (Datron 4708, Option 10) can produce dangerous voltages that are present on the terminals. Do not touch the front (or rear) panel terminals unless you are sure no dangerous voltage is present.

[a] Connect HI and LO leads to DC Standard (see Figure 2-16)

[b] Set DC Standard OUTPUT to -12.8 V

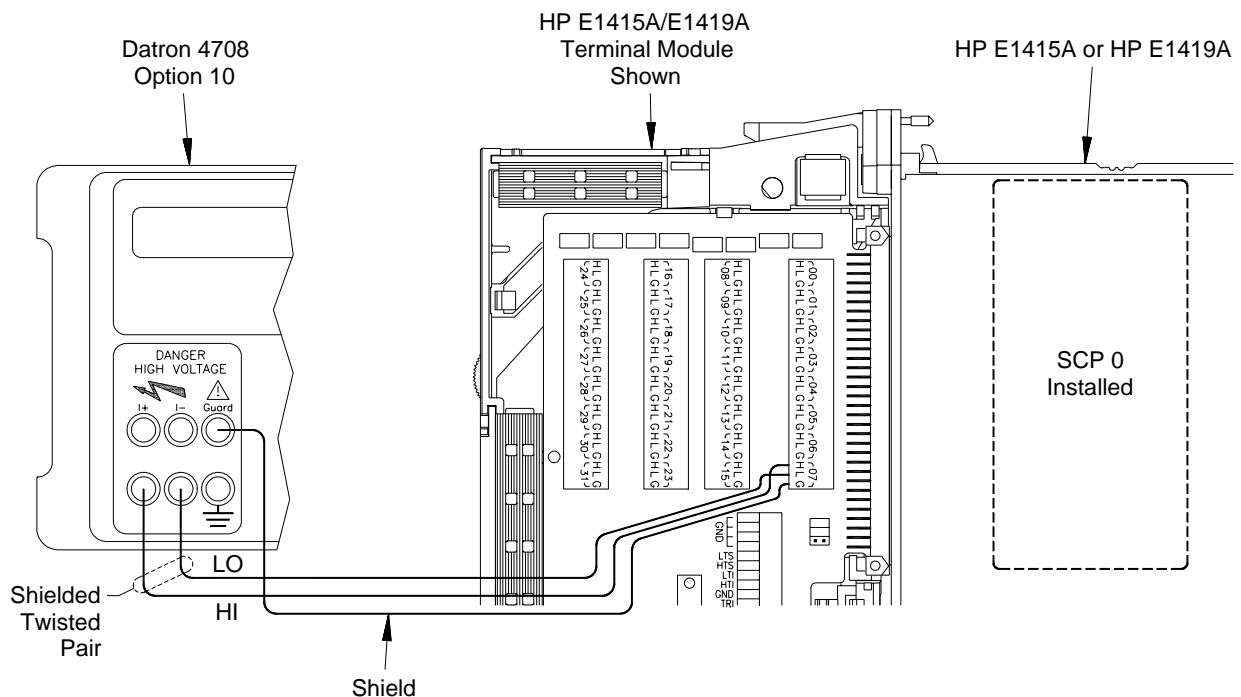

Figure 2-16. DC Standard Connections

5 Make DCV Measurements

*RST;*CLS;*OPC?

Reset module, clear status register

ENTER statement
FUNC:VOLT 1, (@107)

**OPC? return
Set DCV meas, 1V range on ch 07*

TRIG:SOUR TIM
TRIG:TIM 1E-3
TRIG:COUN 400
SAMP:TIM 1E-4

*Sets triggering to timer
Set trigger time to 1 mS
Set trigger count
Pace measurements at 0.1 msec*

ALG:DEF <algorithm>	<i>intervals</i>
CAL:ZERO?	<i>Define algorithm</i>
ENTER statement	<i>Auto zero measurement</i>
INIT:IMM	<i>Wait for CAL:ZERO to complete</i>
DATA:FIFO:PART? 400	<i>Sets Wait for Trigger state</i>
	<i>Returns 400 readings from</i>
	<i>FIFO buffer</i>
ENTER statement	<i>Enters 400 readings</i>
Average = SUM(Result)/400.0	<i>Result is average of 400</i>
	<i>readings</i>

6 Repeat Measurements for each Input and Range

[a] Set DC Standard OUTPUT to -9.6 V and repeat Step 5 (except for *RST;*CLS;*OPC?)

[b] Repeat [a] for the inputs and ranges in the following table

Controller Range	1.0 V	4.0 V
Inputs (Vdc)	-12.8	-51.2
	-9.6	-38.4
	-6.4	-25.6
	-3.2	-12.8
	0.0	0.0
	3.2	12.8
	6.4	25.6
	9.6	38.4
	12.8	51.2

E1513A Verification Test Programs

To test the E1513A run the "PERF13" program. Typical results for Test 2-16 follows.

Test 2-16: DCV Accuracy - E1513A (PERF13) Typical Results

HP E1415A or HP E1419A DC Voltage Accuracy Test E1513A Divide by 16 SCP				
Range	Input	Minimum	Reading	Maximum
1.0 V	-12.8 V	-12.8031 V	-12.8011 mV	-12.7969 V
1.0 V	- 9.6 V	- 9.6024 V	- 9.6002 mV	- 9.5976 V
.
4.0 V	+51.2 V	+51.1878 V	+51.2073 V	+51.2122 V

Test 2-17: DCV Accuracy - E1514A and E1515A

Test Program Description Test 2-17 (test program PERF14_15.C) checks HP E1415A or HP E1419A DC voltage measurement accuracy when an E1514A or E1515A Fixed Filter and Amplifier SCP is used.

Note View complete performance verification test procedures by opening the SCP test program source file in any standard word processor (e.g., MS WORD, WordPad, Notepad, etc.). You can print a hard copy version to view along with this chapter. The test descriptions provided in this chapter are simply "summaries" which supplement the test set-up diagrams. These test summaries support the test programs but are not intended to provide a full replacement in a written format.

Test Summary 1 Make Channel Tare/Calibration Connections

[a] Connect wiring to terminal block (see Figure 2-17)

[b] Connect terminal block to installed HP E1415A or E1419A

Note The procedure shown uses channel 07. Substitute the appropriate channel number and SCP number if you use another channel.

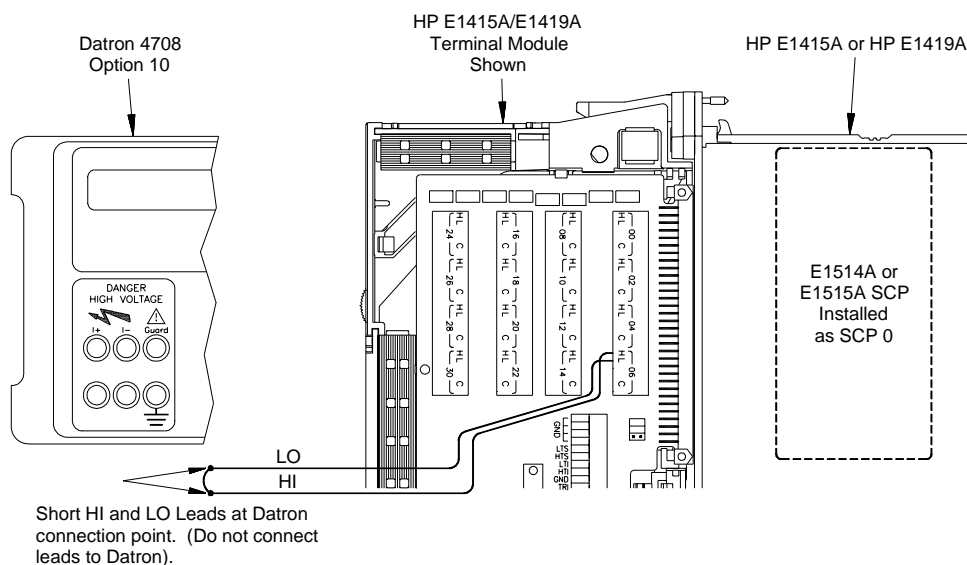

Figure 2-17. Channel Tare/Calibration Connections

2 Check SCP 0 type (must be E1514A or E1515A)

SYST:CTYP? (@107)
ENTER statement

Check SCP 0 type
Returns SCP type

3 Perform Channel Calibrations

CAL:TARE (@107)
CAL:ZERO?
ENTER statement

*Perform CAL TARE
Auto zero measurement
Wait for CAL:ZERO results*

4 Make Connections to DC Standard

WARNING The DC Standard (Datron 4708, Option 10) can produce dangerous voltages that are present on the terminals. Do not touch the front (or rear) panel terminals unless you are sure no dangerous voltage is present.

[a] Connect HI and LO leads to DC Standard (see Figure 2-18)

[b] Set DC Standard OUTPUT to -12.8 V

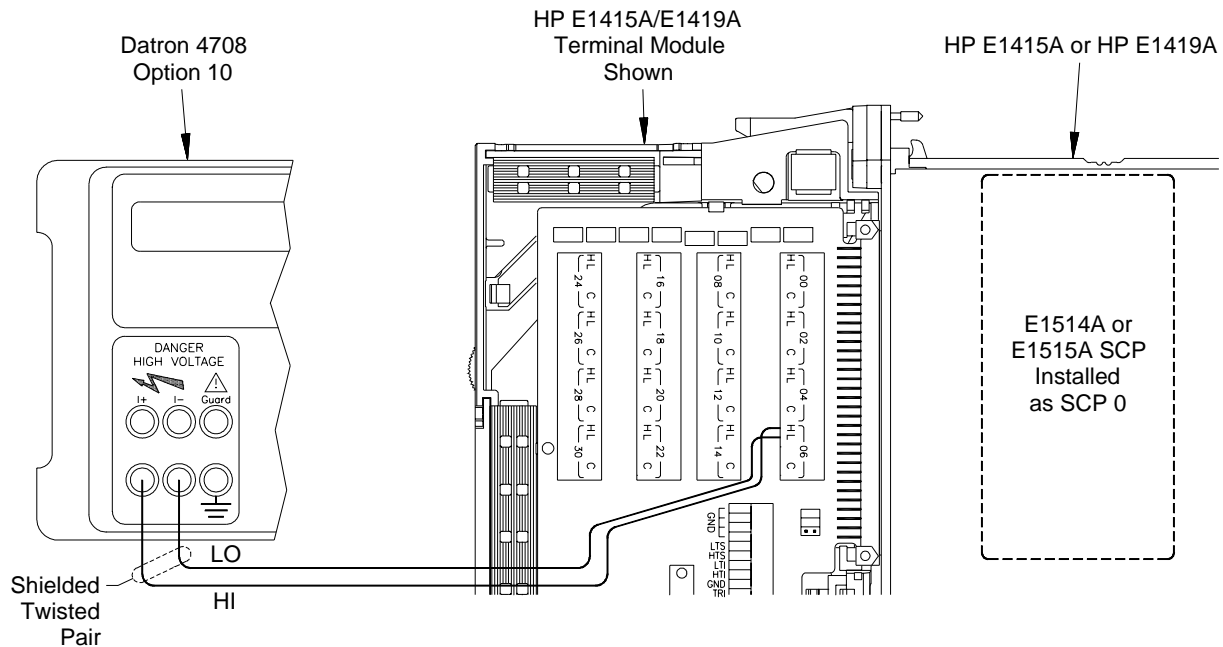

Figure 2-18. DC Standard Connections

5 Make DCV Measurements

*RST;*CLS;*OPC?

ENTER statement
FUNC:VOLT 16, (@107)

TRIG:SOUR TIM
TRIG:TIM 1E-3
TRIG:COUN 400
SAMP:TIM 1E-4

*Reset module, clear status register
*OPC? return
Set DCV meas, 16V range on 107
Sets triggering to timer
Set trigger time
Set trigger count
Pace measurements at 0.1 msec intervals*

ALG:DEF <algorithm>
 CAL:ZERO?
 ENTER statement
 INIT:IMM
 DATA:FIFO:PART? 400

Define algorithm
Auto zero measurement
Wait for CAL:ZERO to complete
Sets Wait for Trigger state
Returns 400 readings from
FIFO buffer

ENTER statement
 Average = SUM(Result)/400.0

Enters 400 readings
Result is average of 400
readings

6 Repeat Measurements for each Input on the 16V Range

[a] Set DC Standard OUTPUT to -9.6 V and repeat Step 5 (except for *RST;*CLS;*OPC?)

[b] Repeat [a] for the inputs in the following table

Controller Range	16.0 V
Inputs (Vdc)	-12.8
	-9.6
	-6.4
	-3.2
	0.0
	3.2
	6.4
	9.6
	12.8

E1514A and E1515A Verification Test Programs

To test the E1514A or E1515A run the "PERF14_15" program. Typical results for Test 2-17 follows.

Test 2-17: DCV Accuracy - E1514A or E1515A (PERF14_15) Typical Results

HP E1415A or HP E1419A DC Voltage Accuracy Test E1514A or E1515A SCP				
Range	Input	Minimum	Reading	Maximum
16.0 V	-12.8 V	-12.8029 V	-12.8007 mV	-12.7971 V
16.0 V	- 9.6 V	- 9.6024 V	- 9.6007mV	- 9.5976 V
.
16.0 V	+12.8 V	+12.7971 V	+12.8019 V	+12.8029 V

Test 2-18: DCV Accuracy - E1516A and E1517A

Test Program Description Test 2-18 (test program PERF16_17.C) checks HP E1415A or HP E1419A DC voltage measurement accuracy when an E1516A or E1517A Iso. Fixed Filter and Amplifier SCP is used.

Note View complete performance verification test procedures by opening the SCP test program source file in any standard word processor (e.g., MS WORD, WordPad, Notepad, etc.). You can print a hard copy version to view along with this chapter. The test descriptions provided in this chapter are simply "summaries" which supplement the test set-up diagrams. These test summaries support the test programs but are not intended to provide a full replacement in a written format.

Test Summary 1 Make Channel Tare/Calibration Connections

[a] Connect wiring to terminal block (see Figure 2-19)

[b] Connect terminal block to installed HP E1415A or E1419A

Note The procedure shown uses channel 07. Substitute the appropriate channel number and SCP number if you use another channel.

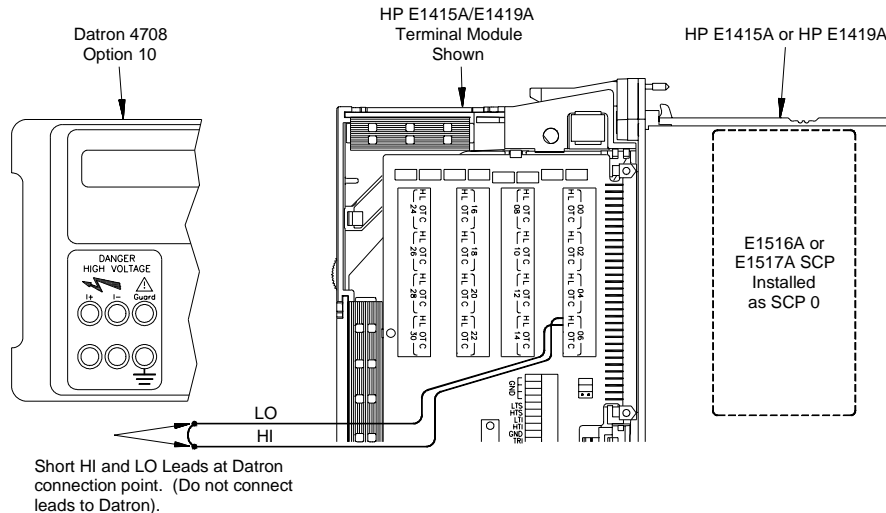

Figure 2-19. Channel Tare/Calibration Connections

2 Check SCP 0 type (must be E1516A or E1517A)

SYST:CTYP? (@107)
ENTER statement

Check SCP 0 type
Returns SCP type

3 Perform Channel Calibrations

CAL:TARE (@107)
CAL:ZERO?
ENTER statement

*Perform CAL TARE
Auto zero measurement
Wait for CAL:ZERO results*

4 Make Connections to DC Standard

WARNING The DC Standard (Datron 4708, Option 10) can produce dangerous voltages that are present on the terminals. Do not touch the front (or rear) panel terminals unless you are sure no dangerous voltage is present.

[a] Connect HI and LO leads to DC Standard (see Figure 2-20)

[b] Set DC Standard OUTPUT to -0.050 V

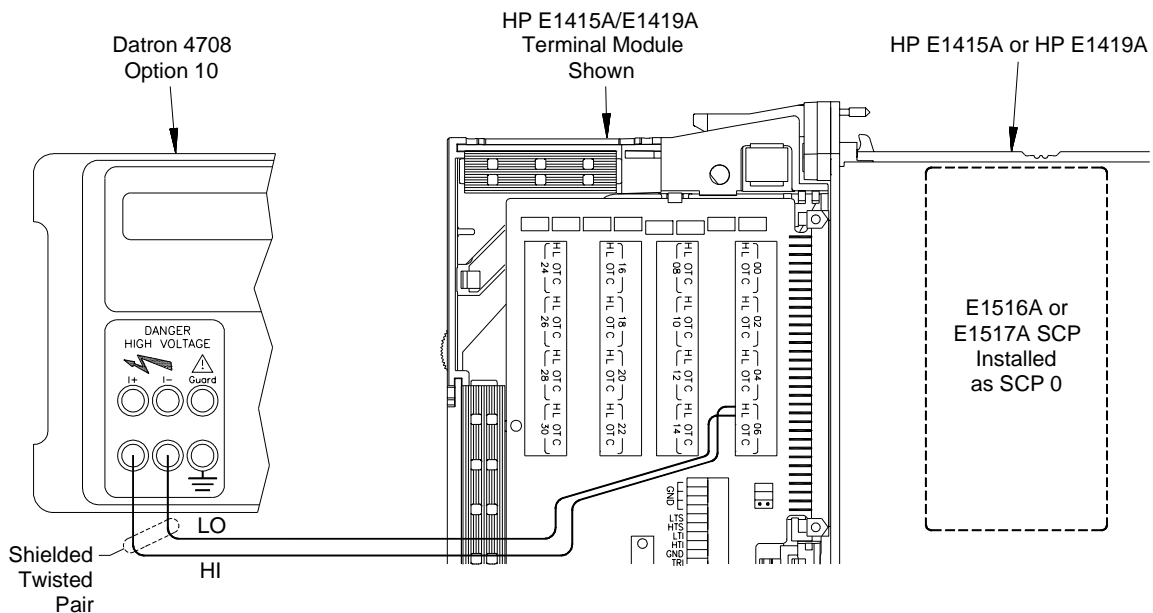

Figure 2-20. DC Standard Connections

5 Make DCV Measurements

*RST;*CLS;*OPC?
ENTER statement
FUNC:VOLT 4, (@107,107)
TRIG:SOUR TIM
TRIG:TIM 1E-3
TRIG:COUN 400
SAMP:TIM 1E-4

*Reset module, clear status register
*OPC? return
Set DCV meas, 4V range on ch 07
Sets triggering to timer
Set trigger timing
Set trigger count
Pace measurements at 0.11 msec intervals*

ALG:DEF <algorithm>
 CAL:ZERO?
 ENTER statement
 INIT:IMM
 DATA:FIFO:PART? 400

Define algorithm
Auto zero measurement
Wait for CAL:ZERO to complete
Sets Wait for Trigger state
Returns 400 readings from
FIFO buffer

ENTER statement
 Average = SUM(Result)/400.0

Enters 400 readings
Result is average of 400
readings

6 Repeat Measurements for each Input on the 4V Range

[a] Set DC Standard OUTPUT to -0.037 V and repeat Step 5 (except for *RST;*CLS;*OPC?)

[b] Repeat [a] for the inputs in the following table

Controller Range	4.0 V
Inputs (Vdc)	-0.050
	-0.037
	-0.025
	-0.012
	0.000
	+0.012
	+0.025
	+0.037
	+0.050

E1516A and E1517A Verification Test Programs

To test the E1516A or E1517A run the "PERF16_17" program. Typical results for Test 2-18 follows.

Test 2-18: DCV Accuracy - E1516A or E1517A (PERF16_17) Typical Results

HP E1415A or HP E1419A DC Voltage Accuracy Test E1516A or E1517A SCP				
Range	Input	Minimum	Reading	Maximum
4.0 V	-0.050 V	-0.050011 V	-0.049992 V	-0.049989 V
4.0 V	-0.037 V	-0.037009 V	-0.037003 V	-0.036991 V
.
4.0 V	+0.050 V	+0.049989 V	+0.049995 V	+0.050011 V

Test 2-19: DCI Accuracy - E1518A

Test Program Description Test 2-19 (test program PERF18I.C) checks DC current output accuracy when an E1518A Current Source SCP is used.

Note View complete performance verification test procedures by opening the SCP test program source file in any standard word processor (e.g., MS WORD, WordPad, Notepad, etc.). You can print a hard copy version to view along with this chapter. The test descriptions provided in this chapter are simply "summaries" which supplement the test set-up diagrams. These test summaries support the test programs but are not intended to provide a full replacement in a written format.

Test Summary 1 Make Channel Connections

- [a] Connect wiring to terminal block and DMM (see Figure 2-21)
- [b] Connect the terminal block to the installed HP E1415A or E1419A
- [c] Connect an HP-IB cable from the DMM to the computer

Note The procedure shown uses channel 00. Substitute the appropriate channel number as required for your application. Using shielded, teflon-coated cable for connections is highly recommended.

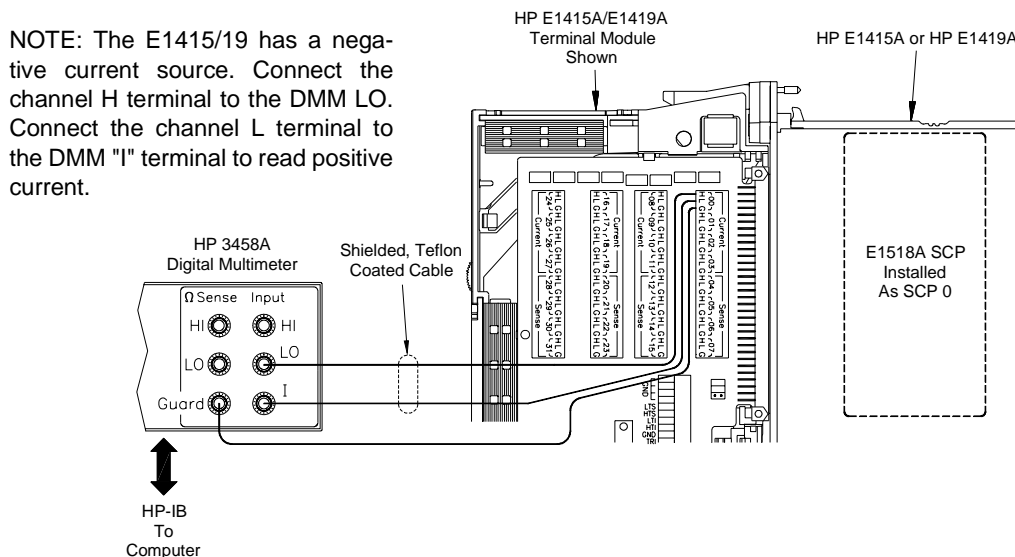

Figure 2-21. Typical Wiring Configurations

2 Check SCP 0 type (must be E1518A)

SYST:CTYP? (@100)

Check SCP 0 type

ENTER statement *Returns SCP type*

3 Perform HP 3458A DMM Autocalibration (Optional)

For most accurate results, an autocalibration (ACAL) of the HP 3458A DMM is recommended every 24 hours. (The autocalibration takes about 12 minutes.) As required, perform an autocalibration with the following command. If autocalibration is not required, go to step 4.

OUTPUT 722;"ACAL ALL" *Performs HP 3458A DMM autocalibration*

4 Perform Channel Calibration (30 μ A range)

Note It is essential to perform a channel calibration (*CAL?) for each current range before measuring the current output on the range. For example, you must set the module for DCI operation on the 30 μ A range and perform *CAL? for the 30 μ A range before measuring the 30 μ A output. The same procedure is required for the 488 μ A range.

OUTP:CURR:STAT ON, (@100) *Enable current output on channel 00*
OUTP:CURR:AMPL 30E-6, (@100) *Set output current on ch 00 to 30 μ A*
*CAL? *Perform *CAL?*
ENTER statement *Return *CAL? results*
CAL:ZERO? *Perform Controller Zero*
ENTER statement *Return CAL:ZERO results*

5 Make DCI Measurement (30 μ A range)

OUTPUT 722;"PRESET NORM" *Set HP 3458A DMM @ address 722 to known state*
OUTPUT 722;"NPLC 100" *Set HP 3458A DMM to NPLC 100*
OUTPUT 722;"DCI 100E-6" *Set DMM range to DCI @ 100 μ A*
WAIT 5 *Wait 5 sec for settling*
ENTER statement *Return DCI reading (~30.518 μ A)*

6 Perform Channel Calibration (488 μ A range)

OUTP:CURR:STAT ON, (@100) *Enable current output on channel 00*
OUTP:CURR:AMPL 488E-6, (@100) *Set output current on ch 00 to 488 μ A*
*CAL? *Perform *CAL?*
ENTER statement *Return *CAL? results*
CAL:ZERO? *Perform Controller Zero*
ENTER statement *Return CAL:ZERO results*

7 Make DCI Measurement (488 μ A range)

OUTPUT 722;"PRESET NORM" *Set HP 3458A DMM @ address 722 to known state*

OUTPUT 722;"NPLC 100"

*Set HP 3458A DMM to NPLC
100*

OUTPUT 722;"DCI 1E-3"

Set DMM range to DCI @ 1 mA

WAIT 5

Wait 5 sec for settling

ENTER statement

*Return DCI reading (~488.28
uA)*

E1518A DC Current Verification Test Program

To perform Test 2-19, run the "PERF18i" program. Typical results for the "PERF18i" program follow.

Test 2-19: DCI Accuracy - E1518A (PERF18i) Typical Results

HP E1415A or HP E1419A DC Current Accuracy Test E1518A Current Source SCP			
Current (μ A)	Minimum (μ A)	Reading (μ A)	Maximum (μ A)
30.518	30.509	30.521	30.527
488.28	488.22	488.29	488.34

Test 2-20: DCV Accuracy - E1518A

Test Program Description Test 2-20 (test program PERF18V.C) checks DC voltage measurement accuracy when an E1518A Resistance Measurement SCP is used.

Note View complete performance verification test procedures by opening the SCP test program source file in any standard word processor (e.g., MS WORD, WordPad, Notepad, etc.). You can print a hard copy version to view along with this chapter. The test descriptions provided in this chapter are simply "summaries" which supplement the test set-up diagrams. These test summaries support the test programs but are not intended to provide a full replacement in a written format.

Test Summary **1 Make Channel Tare/Calibration Connections**

- [a] Connect wiring to terminal block (see Figure 2-22)
- [b] Connect terminal block to installed HP E1415A or E1419A

Note The procedure shown uses channel 07. Substitute the appropriate channel number and SCP number if you use another channel.

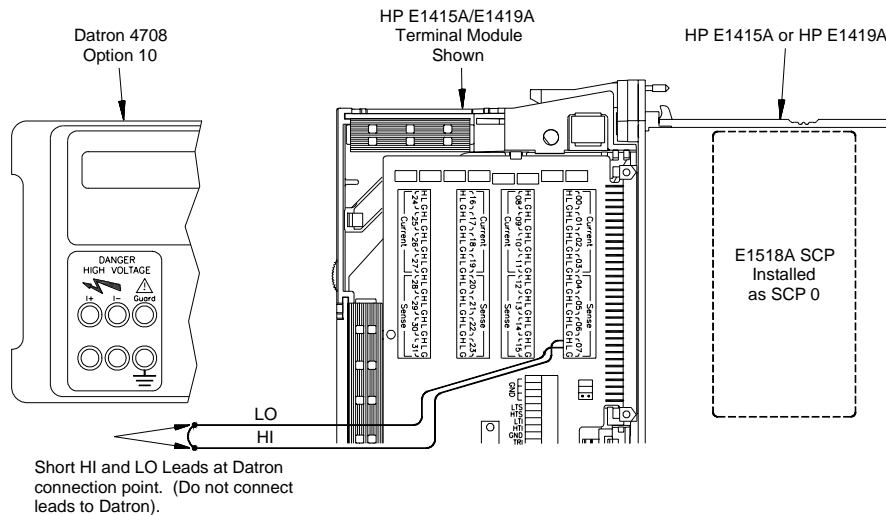

Figure 2-22. Channel Tare/Calibration Connections

2 Check SCP 0 type (must be E1518A)

SYST:CTYP? (@107)
ENTER statement

*Check SCP 0 type
Returns SCP type*

3 Perform Channel Calibrations

CAL:TARE (@107)
CAL:ZERO?
ENTER statement

*Perform CAL TARE
Auto zero measurement
Wait for CAL:ZERO results*

4 Make Connections to DC Standard

WARNING The DC Standard (Datron 4708, Option 10) can produce dangerous voltages that are present on the terminals. Do not touch the front (or rear) panel terminals unless you are sure no dangerous voltage is present.

[a] Connect HI and LO leads to DC Standard (see Figure 2-23)

[b] Set DC Standard OUTPUT to -3 mV

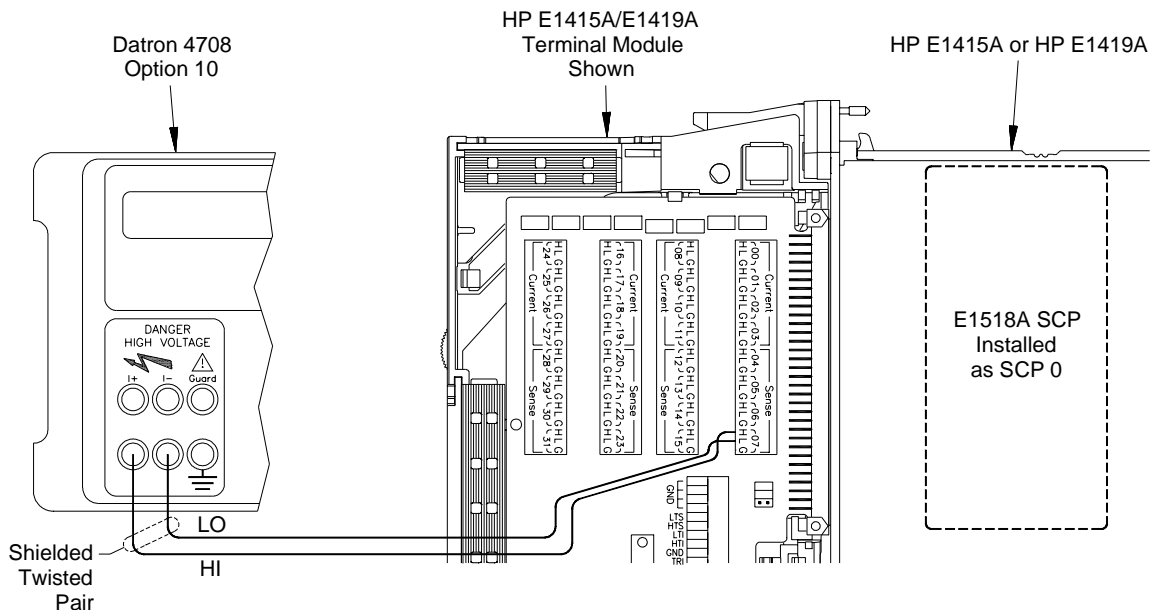

Figure 2-23. DC Standard Connections

5 Make DCV Measurements

*RST;*CLS;*OPC?

ENTER statement
FUNC:VOLT .0625, (@107,107)

TRIG:SOUR TIM
TRIG:TIM 1E-3
TRIG:COUN 400
SAMP:TIM 1E-

*Reset module, clear status register
*OPC? return
Set DCV meas, .0625V range on ch 07
Sets triggering to timer
Set trigger timing
Set trigger count
Pace measurements at 0.1 msec*

ALG:DEF <algorithm>
 CAL:ZERO?
 ENTER statement
 INIT:IMM
 DATA:FIFO:PART? 400

 ENTER Statement
 Average = SUM(Result)/400.0

intervals
Define algorithm
Auto zero measurement
Wait for CAL:ZERO to complete
Sets Wait for Trigger state
Returns 400 readings from
FIFO buffer
Enters 400 readings
Result is average of 400
readings

6 Repeat Measurements for each input and range

- [a] Set DC Standard OUTPUT to -2.3 mV and repeat Step 5 (except for *RST;*CLS;*OPC?)
- [b] Repeat [a] for the inputs and ranges in the following table

Controller Range	.0625 V	.25 V	1.0 V	4.0 V	16.0 V
Input (mV)	-3.0	-13	-50	-200	-800
	-2.3	-9	-38	-150	-600
	-1.5	-6	-25	-100	-400
	-0.8	-3	-13	-50	-200
	0	0	0	0	0
	0.8	3	13	50	200
	1.5	6	25	100	400
	2.3	9	38	150	600
	3.0	13	50	200	800

E1518A DC Voltage Verification Test Programs

To perform Test 2-20, run the "PERF18V" program. Typical results for Test 2-20 follow.

Test 2-20: DCV Accuracy - E1518A (PERF18V) Typical Results

HP E1415A or HP E1419A DC Voltage Accuracy Test E1518A Fixed Filter+Amplifier SCP				
Range	Input	Minimum	Reading	Maximum
.0625 V	-3.0 mV	-3.0041 mV	-3.0028 mV	-2.9959 mV
.0625 V	-2.3 mV	-2.3040 mV	-2.3034 mV	-2.2960 mV
.
16.0 V	+800.0 mV	+799.889 mV	+800.0083 mV	+800.111 mV

Test 2-21: DCV Output Accuracy - E1531A

Test Program Description Test 2-21 (test program PERF31.C) checks DC voltage output accuracy when an E1531A 8-Channel Voltage Output SCP is used.

Note View complete performance verification test procedures by opening the SCP test program source file in any standard word processor (e.g., MS WORD, WordPad, Notepad, etc.). You can print a hard copy version to view along with this chapter. The test descriptions provided in this chapter are simply "summaries" which supplement the test set-up diagrams. These test summaries support the test programs but are not intended to provide a full replacement in a written format.

Test Summary 1 Make Channel Connections

- [a] Connect wiring to terminal block and DMM (see Figure 2-24)
- [b] Connect the terminal block to the installed HP 1415A or E1419A
- [c] Connect an HP-IB cable from the DMM to the computer

Note The procedure shown uses channel 100. Substitute the appropriate channel number and SCP number if you use another channel.

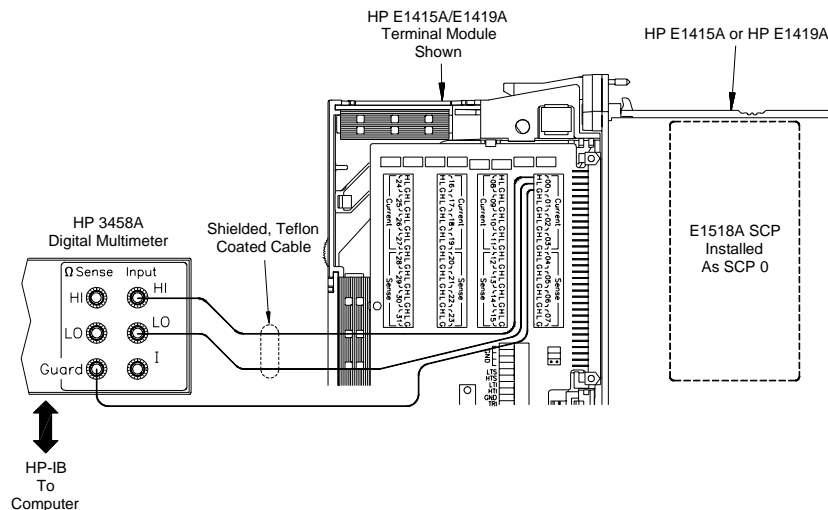

Figure 2-24. Typical DMM Connections for Voltage Measurements.

2 Check SCP 0 type (must be E1531A)

SYST:CTYP? (@107)
ENTER statement

*Check SCP 0 type
Returns SCP type*

3 Make Connections to Multimeter

[a] Connect HI and LO leads to multimeter HI and LO leads.

4 Set Voltage Output Level

*RST;*CLS;*OPC?	<i>Reset module, clear status register</i>
ENTER statement	<i>*OPC? return</i>
ALG:DEF <algorithm>	<i>Define algorithm</i>
Set the voltage output	<i>Set algorithm DCV variable</i>

5 Make Measurements for each of the following outputs:

-15.5V
-5V
0V
+5V
+15.5V

E1531A Verification Test Program To perform Test 2-21, run the "PERF31" program. Typical results for Test 2-21 follow.

Test 2-21: DCV Output Accuracy - E1531A (PERF31) Typical Results

HP E1415A or HP E1419A
DC Voltage Output Accuracy Test
E1531A 8-Channel Voltage Output SCP

Output	Minimum	Reading	Maximum
-15.5V	-15.5067V	-15.5021V	-15.4933V
-5V	-5.0046V	-4.9993V	-4.9954V
0V	-3.6 mV	0.0012V	3.6 mV
+5V	4.9954V	5.0017V	5.0046V
+15.5V	15.4933V	15.4986V	15.5067V

Test 2-22: DCI Output Accuracy - E1532A

Test Program Description Test 2-22 (test program PERF32.C) checks DC current output accuracy when an E1532A 8-Channel Current Output SCP is used.

Note View complete performance verification test procedures by opening the SCP test program source file in any standard word processor (e.g., MS WORD, WordPad, Notepad, etc.). You can print a hard copy version to view along with this chapter. The test descriptions provided in this chapter are simply "summaries" which supplement the test set-up diagrams. These test summaries support the test programs but are not intended to provide a full replacement in a written format.

Test Summary 1 Make Channel Connections

- [a] Connect wiring to terminal block and DMM (see Figure 2-25)
- [b] Connect the terminal block to the installed HP 1415A or E1419A
- [c] Connect an HP-IB cable from the DMM to the computer

Note The procedure shown uses channel 100. Substitute the appropriate channel number and SCP number if you use another channel.

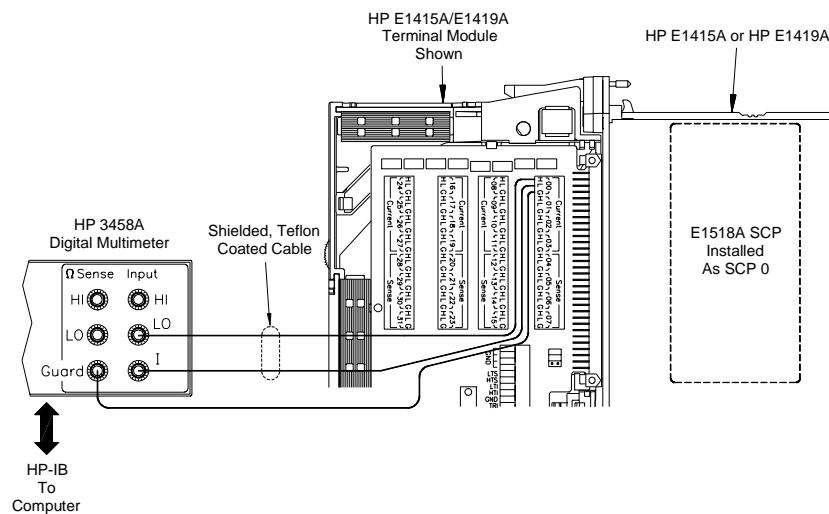

Figure 2-25. Typical DMM Connections for Current Measurements.

2 Check SCP 0 type (must be E1532A)

SYST:CTYP? (@107)
ENTER statement

*Check SCP 0 type
Returns SCP type*

3 Make DCI Measurements

*RST;*CLS;*OPC?

Reset module, clear status register

ENTER statement

**OPC? return*

ALG:DEF <algorithm>

Define algorithm

Set the current output

set algorithm DCI variable

Make multimeter measurement

4 Make Measurements for each of the following outputs:

-9.5mA

-5mA

0A

+5mA

+9.5mA

E1532A Verification Test Program

To perform Test 2-22, run the "PERF32" program. Typical results for Test 2-22 follow.

Test 2-22: DCI Output Accuracy - E1532A (PERF32) Typical Results

HP E1415A or HP E1419A
DC Current Output Accuracy Test
E1532A 8-Channel Current Output SCP

Ouput	Minimum	Reading	Maximum
-9.5 mA	-9.5090 mA	-9.4998 mA	-9.4910 mA
-5 mA	-5.0066 mA	-4.9993 mA	-4.9934 mA
0 mA	-3.3 mA	0.128 mA	3.3 mA
+5 mA	4.9954 mA	5.0017 mA	5.0066 mA
+9.5 mA	9.4910 mA	9.5009 mA	9.5090 mA

Test 2-23: 16-Bit Digital I/O - E1533A

Test Program Description Test 2-23 (test program PERF33.C) checks both the input and output modes of the 16-bit (2-channel) Digital I/O when an E1533A 16-Bit Digital I/O SCP is used.

Note View complete performance verification test procedures by opening the SCP test program source file in any standard word processor (e.g., MS WORD, WordPad, Notepad, etc.). You can print a hard copy version to view along with this chapter. The test descriptions provided in this chapter are simply "summaries" which supplement the test set-up diagrams. These test summaries support the test programs but are not intended to provide a full replacement in a written format.

Test Summary 1 Make Terminal Module Connections

[a] Connect wiring on terminal block (see Figure 2-26)

[b] Connect terminal block to installed HP E1415A or E1419A

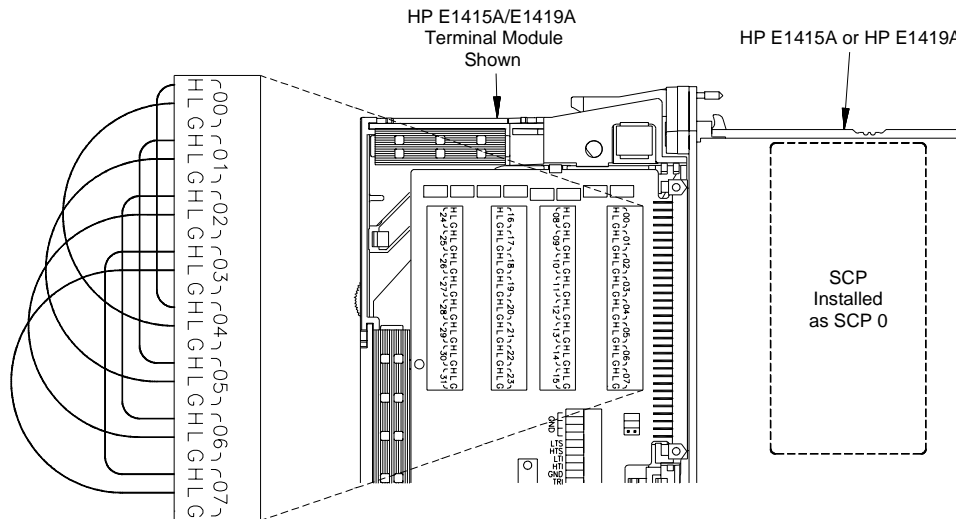

Figure 2-26. Channel-to-Channel Digital I/O Connections

2 Check SCP 0 type (must be E1533A)

SYST:CTYP? (@100)
ENTER statement

*Check SCP 0 type
Returns SCP type*

3 Set Output Bits on Channel 100

*RST;*CLS;*OPC?
ENTER statement
ALG:DEF <algorithm>

*Reset module, clear status
register
*OPC? return
Define algorithm*

Set the output bits to 01

4 Read Input Bits on Channel 101

Verify input reads 01.

5 Repeat Setting Output and Reading Input for the following Bit Values:

2, 4, 8, 16, 32, 64, 128, 255, 0

E1533A Verification Test Program

To perform Test 2-23, run the "PERF33" program.

Test 2-24: 8-Bit Frequency/Totalize/PWM - E1534A

Test Program Description Test 2-24 (test program PERF34.C) checks the frequency and pulse width modes when an E1534A 8-bit frequency/totalize/PWM SCP is used.

Note View complete performance verification test procedures by opening the SCP test program source file in any standard word processor (e.g., MS WORD, WordPad, Notepad, etc.). You can print a hard copy version to view along with this chapter. The test descriptions provided in this chapter are simply "summaries" which supplement the test set-up diagrams. These test summaries support the test programs but are not intended to provide a full replacement in a written format.

Test Summary 1 Make Terminal Module Connections

[a] Connect wiring from terminal block to frequency generator (see Figure 2-27)

[b] Connect terminal block to installed HP E1415A or E1419A

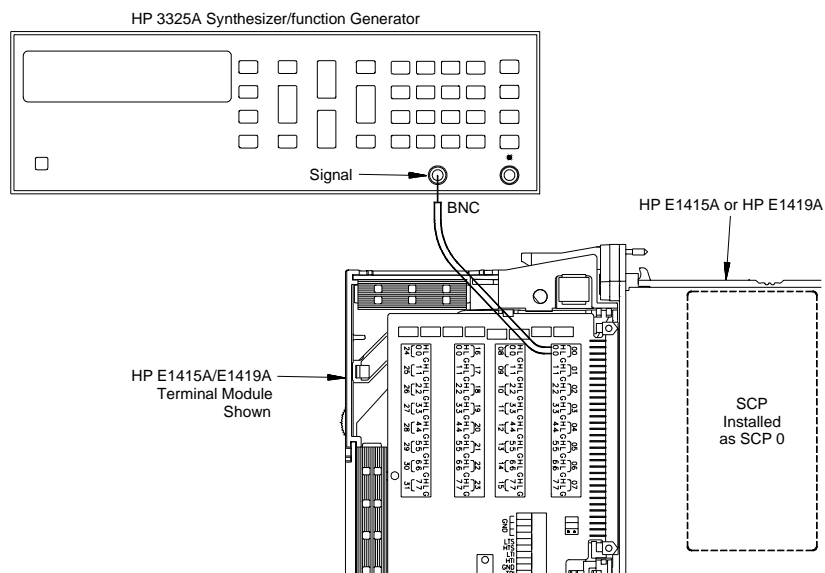

Figure 2-27. Frequency Counter Connections

2 Check SCP 0 type (must be E1534A)

SYST:CTYP? (@100)
ENTER statement

*Check SCP 0 type
Returns SCP type*

3 Set Up Module Channel 100 for Counter Measurements

*RST;*CLS;*OPC?
ENTER statement
ALG:DEF <algorithm>

*Reset module, clear status
register
*OPC? return
Define algorithm*

SENS:FUNC:FREQ <channel>
SENS:FREQ:APER 0.1

Set frequency function
Set aperture

4 Set the Frequency Source Output

Set the frequency source:
5V TTL square wave @ 1 kHz

5 Make 1 kHz Measurement and Repeat Measurement for the Following Frequencies:

10 kHz, 50 kHz, 100 kHz

6 Set Up Channel 100 for Source Measurements

SOUR:FUNC:SQU <channel> *Set source signal*
SOUR:FM ON,<channel>
Set the frequency to 200 Hz in the algorithm

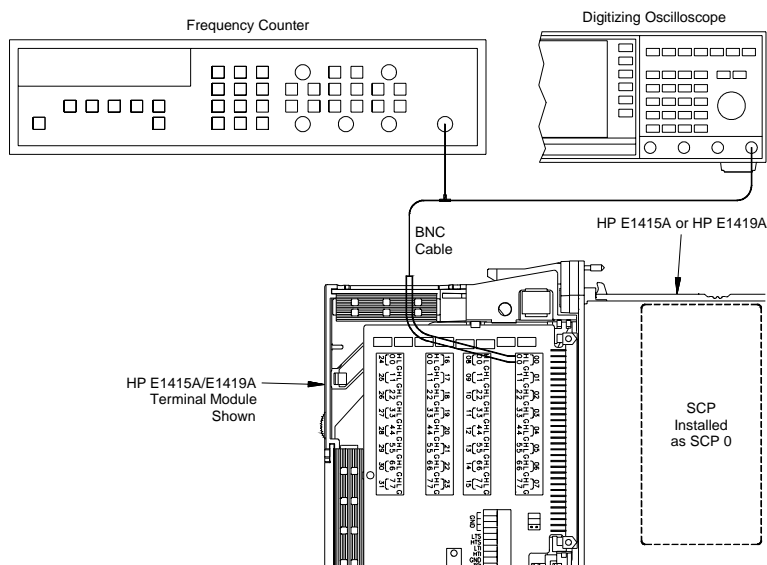

Figure 2-28. Frequency Source Connections

7 Make 200 Hz Measurement and Repeat Measurement for the Following Frequencies:

10 kHz, 20 kHz, 40 kHz

E1534A Verification Test Program

To perform Test 2-24, run the "PERF34" program.

Test 2-25: Watchdog Timer - E1535A

Test Program Description Test 2-25 (test program PERF35.C) checks the timer and alarm modes when an E1535A Watchdog Timer SCP is used.

Note View complete performance verification test procedures by opening the SCP test program source file in any standard word processor (e.g., MS WORD, WordPad, Notepad, etc.). You can print a hard copy version to view along with this chapter. The test descriptions provided in this chapter are simply "summaries" which supplement the test set-up diagrams. These test summaries support the test programs but are not intended to provide a full replacement in a written format.

Test Summary 1 Make Terminal Module Connections

[a] Connect wiring on terminal block (see Figure 2-29)

[b] Connect terminal block to installed HP E1415A or E1419A

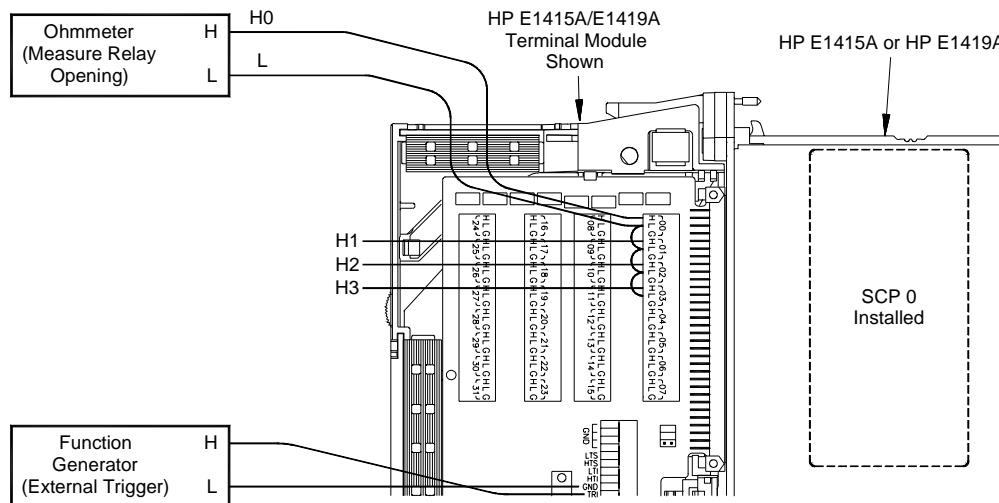

Figure 2-29. Watchdog Timer Functional Test Connections

2 Check SCP 0 type (must be E1535A)

SYST:CTYP? (@100)
ENTER statement

*Check SCP 0 type
Returns SCP type*

3 Set Output Bits on Channel 100

*RST;*CLS;*OPC?
ENTER statement
Set the output bits to 01

*Reset module, clear status
register
OPC? return

4 Read Input Bits on Channel 101

Verify input reads 01.

5 Repeat Setting Output and Reading Input for the following Bit Values:

2, 4, 8, 16, 32, 64, 128, 255, 0

E1535A Verification Test Program

To perform Test 2-25, run the "PERF35" program.

Test 2-26: 8-Bit Isolated Digital I/O - E1536A

Test Program Description Test 2-26 (test program PERF36.C) checks both the input and output modes of the 8-bit Isolated Digital I/O when an E1536A 8-Bit Isolated Digital I/O SCP is used.

Note View complete performance verification test procedures by opening the SCP test program source file in any standard word processor (e.g., MS WORD, WordPad, Notepad, etc.). You can print a hard copy version to view along with this chapter. The test descriptions provided in this chapter are simply "summaries" which supplement the test set-up diagrams. These test summaries support the test programs but are not intended to provide a full replacement in a written format.

Test Summary 1 Make Terminal Module Connections

[a] Connect wiring on terminal block (see Figure 2-30)

[b] Connect terminal block to installed HP E1415A or E1419A

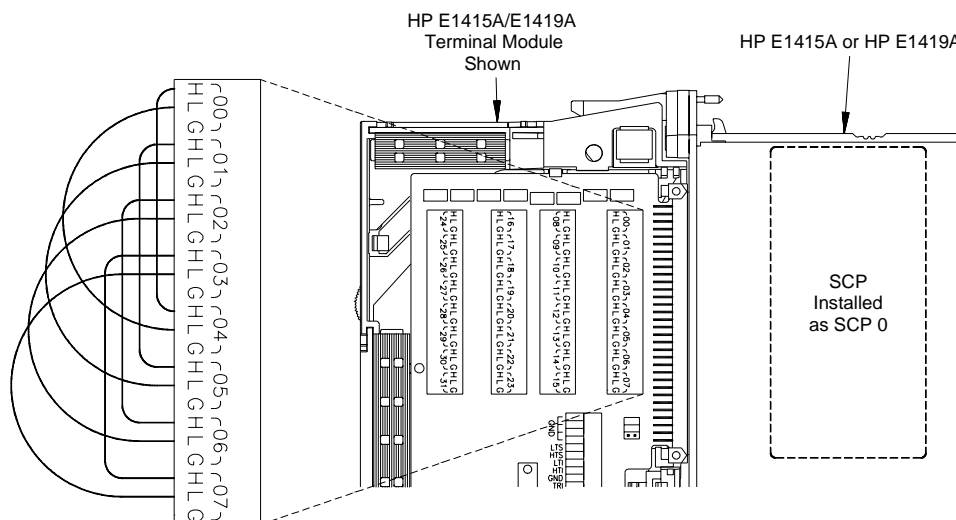

Figure 2-30. Channel-to-Channel Digital I/O Connections

2 Check SCP 0 type (must be E1536A)

SYST:CTYP? (@100)
ENTER statement

*Check SCP 0 type
Returns SCP type*

3 Set Output Bits on Channel 100

*RST;*CLS;*OPC?

ENTER statement
ALG:DEF <algorithm>

*Reset module, clear status
register
*OPC? return
Define algorithm*

Set the output bits to 01

4 Read Input Bits on Channel 101

Verify input reads 01.

5 Repeat Setting Output and Reading Input for the following Bit Values:

2, 4, 8, 16, 32, 64, 128, 255, 0

E1536A Verification Test Program

To perform Test 2-26, run the "PERF36" program.

Test 2-27: DCV Output Accuracy - E1537A

Test Program Description Test 2-27 (test program PERF37.C) checks DC voltage output accuracy when an E1537A 4-Channel Voltage Output SCP is used.

Note View complete performance verification test procedures by opening the SCP test program source file in any standard word processor (e.g., MS WORD, WordPad, Notepad, etc.). You can print a hard copy version to view along with this chapter. The test descriptions provided in this chapter are simply "summaries" which supplement the test set-up diagrams. These test summaries support the test programs but are not intended to provide a full replacement in a written format.

Test Summary **1 Check SCP 0 type (must be E1537A)**

SYST:CTYP? (@107) *Check SCP 0 type*
ENTER statement *Returns SCP type*

2 Make Connections to Multimeter

[a] Connect HI and LO leads to multimeter HI and LO leads.

3 Set Voltage Output Level

*RST;*CLS;*OPC? *Reset module, clear status register*
ENTER statement **OPC? return*
ALG:DEF <algorithm> *Define algorithm*
Set the voltage output *Set algorithm DCV variable*

4 Make Measurements for each of the following outputs:

-15.5V
-5V
0V
+5V
+15.5V

E1537A Verification Test Program To perform Test 2-27, run the "PERF37" program. Typical results for Test 2-27 follow.

Test 2-27: DCV Output Accuracy - E1537A (PERF37) Typical Results

HP E1415A or HP E1419A
DC Voltage Output Accuracy Test
E1537A 8-Channel Voltage Output SCP

Ouput	Minimum	Reading	Maximum
-15.5V	-15.5067V	-15.5021V	-15.4933V
-5V	-5.0046V	-4.9993V	-4.9954V
0V	-3.6 mV	0.0012V	3.6 mV
+5V	4.9954V	5.0017V	5.0046V
+15.5V	15.4933V	15.4986V	15.5067V

Test 2-28: Enhanced Frequency/Totalize/PWM - E1538A

Test Program Description Test 2-28 (test program PERF38.C) checks the frequency and pulse width modes when an E1538A enhanced frequency/totalize/PWM SCP is used. It also functionally checks the VRS input circuitry.

Note View complete performance verification test procedures by opening the SCP test program source file in any standard word processor (e.g., MS WORD, WordPad, Notepad, etc.). You can print a hard copy version to view along with this chapter. The test descriptions provided in this chapter are simply "summaries" which supplement the test set-up diagrams. These test summaries support the test programs but are not intended to provide a full replacement in a written format.

Test Summary 1 Make Terminal Module Connections

[a] Connect wiring from terminal block to frequency generator (see Figure 2-31)

[b] Connect terminal block to installed HP E1415A or E1419A

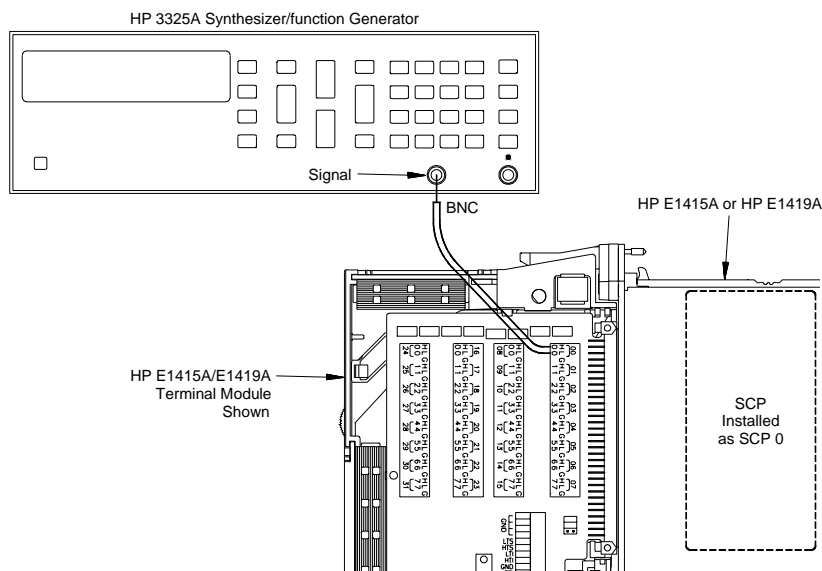

Figure 2-31. Frequency Counter Connections

2 Check SCP 0 type (must be E1538A)

SYST:CTYP? (@100)
ENTER statement

*Check SCP 0 type
Returns SCP type*

3 Set Up Module Channel 100 for Counter Measurements

*RST;*CLS;*OPC?

ENTER statement

*Reset module, clear status
register
OPC? return

ALG:DEF <algorithm>
SENS:FUNC:FREQ <channel>
SENS:FREQ:APER 0.1

Define algorithm
Set frequency function
Set aperture

4 Set the Frequency Source Output

Set the frequency source:
5V TTL square wave @ 1 kHz

5 Make 1 kHz Measurement and Repeat Measurement for the Following Frequencies:

10 kHz, 50 kHz, 100 kHz

6 Set Up Channel 100 for Source Measurements

[a] Connect wiring from terminal block to frequency generator
(see Figure 2-32)

SOUR:FUNC:SQU <channel>
SOUR:FM ON,<channel>

Set source signal

Set the frequency to 200 Hz in the algorithm

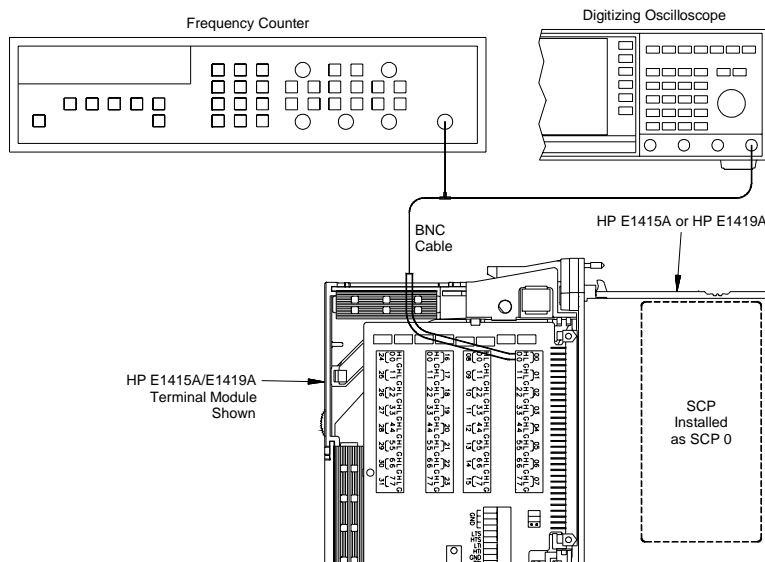

Figure 2-32. Frequency Source Connections

7 Make 200 Hz Measurement and Repeat Measurement for the Following Frequencies:

10 kHz, 20 kHz, 40 kHz

8 Make Pulse Width Measurements

INP:THR:LEV 0, <channel>
TRIG:SOUR TIM

Set threshold level
Set trigger to timer

```

TRIG:TIM 1E-3
TRIG:COUN 100
SENS:FUNC:PWID 100, <channel>
SAMP:TIM 1E-5
INIT

```

Set trigger time to 1 mS
Set trigger count to 100
Set pulse width
Set sample time
Initiate measurement

9 Set Up to Make Pulse Source Measurements

[a] Connect wiring from terminal block to counter and oscilloscope (see Figure 2-33)

[b] Connect a 500Ω resistor from the High lead to a +5V power supply. Connect the power supply common to the Low lead. (see Figure 2-33)

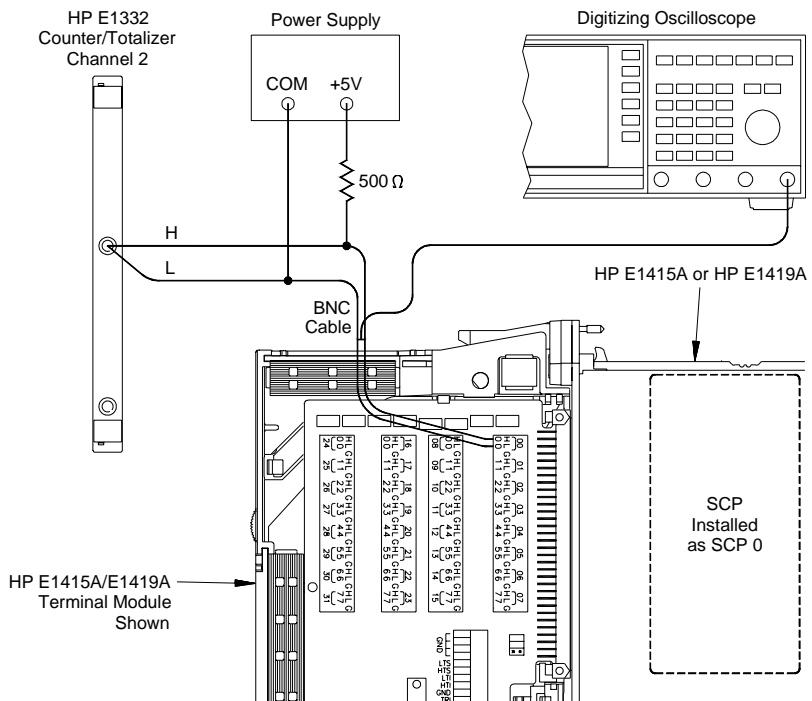

Figure 2-33.

10 Make Pulse Source Measurements

```

SOUR:FUNC:PULS <channel>
SOUR:FM ON, <channel>
SOUR:PULS:WIDT .001
INIT
SOUR:PULS:WIDT 10e-6
SOUR:FM OFF, <channel>
SOUR:PULM ON, <channel>
SOUR:PULS:PER 31.3E-6, <channel>
INIT
SOUR:PULS:PER 2E-3, <channel>
INIT

```

Set function and source signal
Enable FM function
Set pulse width
Initiate pulses
Set pulse width to 10 usec
Disable FM function
Enable Pulse period
Set pulse period
Initiate pulses
Set pulse period
Initiate pulses

11 Set Up Module Channel 100 for Counter Measurements With VAR Input Enabled (verify VAR input circuitry)

*RST;*CLS;*OPC?	<i>Reset module, clear status register</i>
ENTER statement	<i>*OPC? return</i>
ALG:DEF <algorithm>	<i>Define algorithm</i>
SENS:FUNC:FREQ <channel>	<i>Set frequency function</i>
SENS:FREQ:APER 0.1	<i>Set aperture</i>

E1538A Verification Test Program

To perform Test 2-28, run the "PERF38" program.

Performance Test Record

Copy and use Table 2-1, *Performance Test Record*, to record performance verification test results for the HP E1415A. This table shows HP E1415A, instrument accuracy, Datron 4708 Option 10 measurement uncertainty, and test accuracy ratio (TAR) values. See *Appendix A - Calculating HP E1415A and HP E1419A Accuracy* for information on accuracy, measurement uncertainty, and TAR calculations.

Test Limits

Test limits are defined using the 90 day specifications in *Appendix A of this manual*. See *Appendix A - Calculating HP E1415A and HP E1419A Accuracy* in this manual for sample calculations of HP E1415A and HP E1419A test limits.

Measurement Uncertainty

For the performance verification tests in this manual, the measurement uncertainties are based on the 90-day accuracy specifications for the Datron 4708 Source and HP 3458A DMM. See *Appendix A - Calculating HP E1415A and HP E1419A Accuracy* in this manual for sample calculations of measurement uncertainty.

Test Accuracy Ratio (TAR)

Test Accuracy Ratio (TAR) for the HP E1415A and HP E1419A is defined as HP E1415A and HP E1419A Accuracy divided by Measurement Uncertainty, where accuracy = maximum allowable value - expected reading. That is:

$$TAR = \frac{\text{Maximum Value} - \text{Expected Reading}}{\text{Measurement Uncertainty}}$$

For TARs that exceed 10:1, the entry is ">10:1".

Table 2-1. Performance Test Record for the HP E1415A and HP E1419A (Page 2 of 37)

Test Equipment Used: Description	Model No.	Trace No.	Cal Due Date
1. _____	_____	_____	_____
2. _____	_____	_____	_____
3. _____	_____	_____	_____
4. _____	_____	_____	_____
5. _____	_____	_____	_____
6. _____	_____	_____	_____
7. _____	_____	_____	_____
8. _____	_____	_____	_____
9. _____	_____	_____	_____
10. _____	_____	_____	_____
11. _____	_____	_____	_____
12. _____	_____	_____	_____
13. _____	_____	_____	_____
14. _____	_____	_____	_____
15. _____	_____	_____	_____
16. _____	_____	_____	_____
17. _____	_____	_____	_____
18. _____	_____	_____	_____
19. _____	_____	_____	_____
20. _____	_____	_____	_____

Table 2-1. Performance Test Record for the HP E1415A and HP E1419A (Page 3 of 37)

Test 2-1: DCV Measurement Accuracy - E1501A Straight-Through SCP							
Ctlr Range	Input	Minimum	Measured	Maximum	M.U.*	TAR**	
.0625 V	- 50.0000 mV	- 50.0112 mV	_____	- 49.9888 mV	7.5E-7 V	>10:1	
	- 37.0000 mV	- 37.0099 mV	_____	- 36.9901 mV	6.6E-7 V	>10:1	
	- 25.0000 mV	- 25.0087 mV	_____	- 24.9913 mV	5.8E-7 V	>10:1	
	- 12.0000 mV	- 12.0074 mV	_____	- 11.9926 mV	4.8E-7 V	>10:1	
	0.0000 mV	- 0.0062 mV	_____	+ 0.0062 mV	4.0E-7 V	>10:1	
	+ 12.0000 mV	+ 11.9926 mV	_____	+ 12.0074 mV	4.8E-7 V	>10:1	
	+ 25.0000 mV	+ 24.9913 mV	_____	+ 25.0087 mV	5.8E-7 V	>10:1	
	+ 37.0000 mV	+ 36.9901 mV	_____	+ 37.0099 mV	6.6E-7 V	>10:1	
	+ 50.0000 mV	+ 49.9888 mV	_____	+ 50.0112 mV	7.5E-7 V	>10:1	
	.25 V	- 200.0000 mV	- 200.0325 mV	_____	- 199.9675 mV	1.6E-6 V	>10:1
		- 150.0000 mV	- 150.0275 mV	_____	- 149.9725 mV	1.4E-6 V	>10:1
- 100.0000 mV		- 100.0226 mV	_____	- 99.9775 mV	1.2E-6 V	>10:1	
- 50.0000 mV		- 50.0176 mV	_____	- 49.9825 mV	1.0E-6 V	>10:1	
0.0000 mV		- 0.0126 mV	_____	+ 0.0126 mV	8.0E-7 V	>10:1	
+ 50.0000 mV		+ 49.9825 mV	_____	+ 50.0176 mV	1.0E-6 V	>10:1	
+100.0000 mV		+ 99.9775 mV	_____	+100.0226 mV	1.2E-6 V	>10:1	
+150.0000 mV		+149.9725 mV	_____	+150.0275 mV	1.4E-6 V	>10:1	
+200.0000 mV		+199.9675 mV	_____	+200.0325 mV	1.6E-6 V	>10:1	
1.0V		- 800.000 mV	- 800.117 mV	_____	- 799.884 mV	4.0E-6 V	>10:1
		- 600.000 mV	- 600.097 mV	_____	- 599.904 mV	3.2E-6 V	>10:1
	- 400.000 mV	- 400.077 mV	_____	- 399.924 mV	2.4E-6 V	>10:1	
	- 200.000 mV	- 200.057 mV	_____	- 199.944 mV	1.6E-6 V	>10:1	
	0.000 mV	- 0.037 mV	_____	+ 0.037 mV	0.8E-6 V	>10:1	
	+200.000 mV	+199.944 mV	_____	+200.057 mV	1.6E-6 V	>10:1	
	+400.000 mV	+399.924 mV	_____	+400.077 mV	2.4E-6 V	>10:1	
	+600.000 mV	+599.904 mV	_____	+600.097 mV	3.2E-6 V	>10:1	
	+800.000 mV	+799.884 mV	_____	+800.117 mV	4.0E-6 V	>10:1	
	4.0V	- 3.2000 V	- 3.2005 V	_____	- 3.1995 V	1.1E-5 V	>10:1
		- 2.4000 V	- 2.4004 V	_____	- 2.3996 V	9.0E-6 V	>10:1
- 1.6000 V		- 1.6003 V	_____	- 1.5997 V	7.0E-6 V	>10:1	
- 0.8000 V		- 0.8002 V	_____	- 0.7998 V	5.0E-6 V	>10:1	
0.0000 V		- 0.0001 V	_____	+0.0001 V	3.0E-6 V	>10:1	
+0.8000 V		+0.7998 V	_____	+0.8002 V	5.0E-6 V	>10:1	
+1.6000 V		+1.5997 V	_____	+1.6003 V	7.0E-6 V	>10:1	
+2.4000 V		+2.3996 V	_____	+2.4004 V	9.0E-6 V	>10:1	
+3.2000 V		+3.1995 V	_____	+3.2005 V	1.1E-5 V	>10:1	
16.0V		- 12.8000 V	- 12.8019 V	_____	- 12.7981 V	1.0E-4 V	>10:1
		- 9.6000 V	- 9.6015 V	_____	- 9.5985 V	8.8E-5 V	>10:1
	- 6.4000 V	- 6.4012 V	_____	- 6.3988 V	7.6E-5 V	>10:1	
	- 3.2000 V	- 3.2009 V	_____	- 3.1991 V	6.3E-5 V	>10:1	
	0.0000 V	- 0.0006 V	_____	+ 0.0006 V	5.0E-5 V	10:1	
	+ 3.2000 V	+ 3.1991 V	_____	+ 3.2009 V	6.3E-5 V	>10:1	
	+ 6.4000 V	+ 6.3988 V	_____	+ 6.4012 V	7.6E-5 V	>10:1	
	+ 9.6000 V	+ 9.5985 V	_____	+ 9.6015 V	8.8E-5 V	>10:1	
	+12.8000 V	+12.7981 V	_____	+12.8019 V	1.0E-4 V	>10:1	

Table 2-1. Performance Test Record for the HP E1415A and HP E1419A (Page 4 of 37)

Test 2-2: DCV Measurement Accuracy - E1502A 7 Hz Low Pass Filter SCP						
Ctlr Range	Input	Minimum	Measured	Maximum	M.U.	TAR
.0625 V	- 50.0000 mV	- 50.0129 mV	_____	- 49.9871 mV	7.5E-7 V	>10:1
	- 37.0000 mV	- 37.0116 mV	_____	- 36.9883 mV	6.6E-7 V	>10:1
	- 25.0000 mV	- 25.0104 mV	_____	- 24.9896 mV	5.8E-7 V	>10:1
	- 12.0000 mV	- 12.0092 mV	_____	- 11.9909 mV	4.8E-7 V	>10:1
	0.0000 mV	- 0.0080 mV	_____	+ 0.0080 mV	4.0E-7 V	>10:1
	+ 12.0000 mV	+ 11.9909 mV	_____	+ 12.0092 mV	4.8E-7 V	>10:1
	+ 25.0000 mV	+ 24.9896 mV	_____	+ 25.0104 mV	5.8E-7 V	>10:1
	+ 37.0000 mV	+ 36.9883 mV	_____	+ 37.0116 mV	6.6E-7 V	>10:1
	+ 50.0000 mV	+ 49.9871 mV	_____	+ 50.0129 mV	7.5E-7 V	>10:1
	.25 V	- 200.0000 mV	- 200.0336 mV	_____	- 199.9664 mV	1.6E-6 V
- 150.0000 mV		- 150.0286 mV	_____	- 149.9714 mV	1.4E-6 V	>10:1
- 100.0000 mV		- 100.0236 mV	_____	- 99.9764 mV	1.2E-6 V	>10:1
- 50.0000 mV		- 50.0186 mV	_____	- 49.9814 mV	1.0E-6 V	>10:1
0.0000 mV		- 0.0136 mV	_____	+ 0.0136 mV	8.0E-7 V	>10:1
+ 50.0000 mV		+ 49.9814 mV	_____	+ 50.0186 mV	1.0E-6 V	>10:1
+100.0000 mV		+ 99.9764 mV	_____	+100.0236 mV	1.2E-6 V	>10:1
+150.0000 mV		+149.9714 mV	_____	+150.0286 mV	1.4E-6 V	>10:1
+200.0000 mV		+199.9664 mV	_____	+200.0336 mV	1.6E-6 V	>10:1
1.0V		- 800.000 mV	- 800.118 mV	_____	- 799.882 mV	4.0E-6 V
	- 600.000 mV	- 600.098 mV	_____	- 599.902 mV	3.2E-6 V	>10:1
	- 400.000 mV	- 400.078 mV	_____	- 399.922 mV	2.4E-6 V	>10:1
	- 200.000 mV	- 200.058 mV	_____	- 199.942 mV	1.6E-6 V	>10:1
	0.000 mV	- .038 mV	_____	+ .038 mV	0.8E-6 V	>10:1
	+200.000 mV	+199.942 mV	_____	+200.058 mV	1.6E-6 V	>10:1
	+400.000 mV	+399.922 mV	_____	+400.078 mV	2.4E-6 V	>10:1
	+600.000 mV	+599.902 mV	_____	+600.098 mV	3.2E-6 V	>10:1
	+800.000 mV	+799.882 mV	_____	+800.118 mV	4.0E-6 V	>10:1
	4.0V	- 3.2000 V	- 3.2005 V	_____	- 3.1995 V	1.1E-5 V
- 2.4000 V		- 2.4004 V	_____	- 2.3996 V	9.0E-6 V	>10:1
- 1.6000 V		- 1.6003 V	_____	- 1.5997 V	7.0E-6 V	>10:1
- 0.8000 V		- 0.8002 V	_____	- 0.7998 V	5.0E-6 V	>10:1
0.0000 V		- 0.0001 V	_____	+0.0001 V	3.0E-6 V	>10:1
+0.8000 V		+0.7998 V	_____	+0.8002 V	5.0E-6 V	>10:1
+1.6000 V		+1.5997 V	_____	+1.6003 V	7.0E-6 V	>10:1
+2.4000 V		+2.3996 V	_____	+2.4004 V	9.0E-6 V	>10:1
+3.2000 V		+3.1995 V	_____	+3.2005 V	1.1E-5 V	>10:1
16.0V		- 12.8000 V	- 12.8018 V	_____	- 12.7982 V	1.0E-4 V
	- 9.6000 V	- 9.6015 V	_____	- 9.5985 V	8.8E-5 V	>10:1
	- 6.4000 V	- 6.4012 V	_____	- 6.3988 V	7.6E-5 V	>10:1
	- 3.2000 V	- 3.2009 V	_____	- 3.1991 V	6.3E-5 V	>10:1
	0.0000 V	- 0.0006 V	_____	+ 0.0006 V	5.0E-5 V	10:1
	+ 3.2000 V	+ 3.1991 V	_____	+ 3.2009 V	6.3E-5 V	>10:1
	+ 6.4000 V	+ 6.3988 V	_____	+ 6.4012 V	7.6E-5 V	>10:1
	+ 9.6000 V	+ 9.5985 V	_____	+ 9.6015 V	8.8E-5 V	>10:1
	+12.8000 V	+12.7982 V	_____	+12.8018 V	1.0E-4 V	>10:1

Table 2-1. Performance Test Record for the HP E1415A and HP E1419A (Page 5 of 37)

Test 2-3: DCV Measurement Accuracy - E1503A Amplifier+Filter SCP (Gain X1, 2 Hz Filter)						
Ctlr Range	Input	Minimum	Measured	Maximum	M.U.	TAR
.0625 V	- 50.0000 mV	- 50.0203 mV	_____	- 49.9798 mV	7.5E-7 V	>10:1
	- 37.0000 mV	- 37.0189 mV	_____	- 36.9811 mV	6.6E-7 V	>10:1
	- 25.0000 mV	- 25.0178 mV	_____	- 24.9823 mV	5.8E-7 V	>10:1
	- 12.0000 mV	- 12.0164 mV	_____	- 11.9836 mV	4.8E-7 V	>10:1
	0.0000 mV	- 0.0153 mV	_____	+ 0.0153 mV	4.0E-7 V	>10:1
	+ 12.0000 mV	+ 11.9836 mV	_____	+ 12.0164 mV	4.8E-7 V	>10:1
	+ 25.0000 mV	+ 24.9823 mV	_____	+ 25.0178 mV	5.8E-7 V	>10:1
	+ 37.0000 mV	+ 36.9811 mV	_____	+ 37.0189 mV	6.6E-7 V	>10:1
	+ 50.0000 mV	+ 49.9798 mV	_____	+ 50.0203 mV	7.5E-7 V	>10:1
	.25 V	- 200.000 mV	- 200.038 mV	_____	- 199.962 mV	1.6E-6 V
- 150.000 mV		- 150.032 mV	_____	- 149.967 mV	1.4E-6 V	>10:1
- 100.000 mV		- 100.028 mV	_____	- 99.972 mV	1.2E-6 V	>10:1
- 50.000 mV		- 50.023 mV	_____	- 49.977 mV	1.0E-6 V	>10:1
0.000 mV		- 0.018 mV	_____	+ 0.018 mV	8.0E-7 V	>10:1
+ 50.000 mV		+ 49.977 mV	_____	+ 50.023 mV	1.0E-6 V	>10:1
+100.000 mV		+ 99.972 mV	_____	+100.028 mV	1.2E-6 V	>10:1
+150.000 mV		+149.967 mV	_____	+150.032 mV	1.4E-6 V	>10:1
+200.000 mV		+199.962 mV	_____	+200.038 mV	1.6E-6 V	>10:1
1.0V		- 800.000 mV	- 800.119 mV	_____	- 799.881 mV	4.0E-6 V
	- 600.000 mV	- 600.099 mV	_____	- 599.901 mV	3.2E-6 V	>10:1
	- 400.000 mV	- 400.079 mV	_____	- 399.921 mV	2.4E-6 V	>10:1
	- 200.000 mV	- 200.059 mV	_____	- 199.941 mV	1.6E-6 V	>10:1
	0.000 mV	- 0.039 mV	_____	- 0.039 mV	0.8E-6 V	>10:1
	+200.000 mV	+199.941 mV	_____	+200.059 mV	1.6E-6 V	>10:1
	+400.000 mV	+399.921 mV	_____	+400.079 mV	2.4E-6 V	>10:1
	+600.000 mV	+599.901 mV	_____	+600.099 mV	3.2E-6 V	>10:1
	+800.000 mV	+799.881 mV	_____	+800.119 mV	4.0E-6 V	>10:1
	4.0V	- 3.2000 V	- 3.2005 V	_____	- 3.1995 V	1.1E-5 V
- 2.4000 V		- 2.4004 V	_____	- 2.3996 V	9.0E-6 V	>10:1
- 1.6000 V		- 1.6003 V	_____	- 1.5997 V	7.0E-6 V	>10:1
- 0.8000 V		- 0.8002 V	_____	- 0.7998 V	5.0E-6 V	>10:1
0.0000 V		- 0.0001 V	_____	+0.0001 V	3.0E-6 V	>10:1
+0.8000 V		+0.7998 V	_____	+0.8002 V	5.0E-6 V	>10:1
+1.6000 V		+1.5997 V	_____	+1.6003 V	7.0E-6 V	>10:1
+2.4000 V		+2.3996 V	_____	+2.4004 V	9.0E-6 V	>10:1
+3.2000 V		+3.1995 V	_____	+3.2005 V	1.1E-5 V	>10:1
16.0V		- 12.8000 V	- 12.8019 V	_____	- 12.7981 V	1.0E-4 V
	- 9.6000 V	- 9.6015 V	_____	- 9.5985 V	8.8E-5 V	>10:1
	- 6.4000 V	- 6.4012 V	_____	- 6.3988 V	7.6E-5 V	>10:1
	- 3.2000 V	- 3.2009 V	_____	- 3.1991 V	6.3E-5 V	>10:1
	0.0000 V	- 0.0006 V	_____	+ 0.0006 V	5.0E-5 V	>10:1
	+ 3.2000 V	+ 3.1991 V	_____	+ 3.2009 V	6.3E-5 V	>10:1
	+ 6.4000 V	+ 6.3988 V	_____	+ 6.4012 V	7.6E-5 V	>10:1
	+ 9.6000 V	+ 9.5985 V	_____	+ 9.6015 V	8.8E-5 V	>10:1
	+12.8000 V	+12.7981 V	_____	+12.8019 V	1.0E-4 V	>10:1

Table 2-1. Performance Test Record for the HP E1415A and HP E1419A (Page 6 of 37)

Test 2-3: DCV Measurement Accuracy - E1503A Amplifier+Filter SCP (Gain X1, 10 Hz Filter)						
Ctlr Range	Input	Minimum	Measured	Maximum	M.U.	TAR
.0625 V	- 50.0000 mV	- 50.0168 mV	_____	- 49.9832 mV	7.5E-7 V	>10:1
	- 37.0000 mV	- 37.0154 mV	_____	- 36.9845 mV	6.6E-7 V	>10:1
	- 25.0000 mV	- 25.0143 mV	_____	- 24.9857 mV	5.8E-7 V	>10:1
	- 12.0000 mV	- 12.0130 mV	_____	- 11.9871 mV	4.8E-7 V	>10:1
	0.0000 mV	- 0.0118 mV	_____	+ 0.0118 mV	4.0E-7 V	>10:1
	+ 12.0000 mV	+ 11.9871 mV	_____	+ 12.0130 mV	4.8E-7 V	>10:1
	+ 25.0000 mV	+ 24.9857 mV	_____	+ 25.0143 mV	5.8E-7 V	>10:1
	+ 37.0000 mV	+ 36.9845 mV	_____	+ 37.0154 mV	6.6E-7 V	>10:1
	+ 50.0000 mV	+ 49.9832 mV	_____	+ 50.0168 mV	7.5E-7 V	>10:1
	.25 V	- 200.0000 mV	- 200.0357 mV	_____	- 199.9644 mV	1.6E-6 V
- 150.0000 mV		- 150.0306 mV	_____	- 149.9693 mV	1.4E-6 V	>10:1
- 100.0000 mV		- 100.0257 mV	_____	- 99.9744 mV	1.2E-6 V	>10:1
- 50.0000 mV		- 50.0206 mV	_____	- 49.9794 mV	1.0E-6 V	>10:1
0.0000 mV		- 0.0157 mV	_____	+ 0.0157 mV	8.0E-7 V	>10:1
+ 50.0000 mV		+ 49.9794 mV	_____	+ 50.0206 mV	1.0E-6 V	>10:1
+100.0000 mV		+ 99.9744 mV	_____	+100.0257 mV	1.2E-6 V	>10:1
+150.0000 mV		+149.9693 mV	_____	+150.0306 mV	1.4E-6 V	>10:1
+200.0000 mV		+199.9644 mV	_____	+200.0357 mV	1.6E-6 V	>10:1
1.0V		- 800.0000 mV	- 800.1174 mV	_____	- 799.8826 mV	4.0E-6 V
	- 600.0000 mV	- 600.0974 mV	_____	- 599.9026 mV	3.2E-6V	>10:1
	- 400.0000 mV	- 400.0774 mV	_____	- 399.9226 mV	2.4E-6 V	>10:1
	- 200.0000 mV	- 200.0574 mV	_____	- 199.9426 mV	1.6E-6 V	>10:1
	0.0000 mV	- 0.0374 mV	_____	+ 0.0374 mV	0.8E-6 V	>10:1
	+200.0000 mV	+199.9426 mV	_____	+200.0574 mV	1.6E-6 V	>10:1
	+400.0000 mV	+399.9226 mV	_____	+400.0774 mV	2.4E-6 V	>10:1
	+600.0000 mV	+599.9026 mV	_____	+600.0974 mV	3.2E-6 V	>10:1
	+800.0000 mV	+799.8826 mV	_____	+800.1174 mV	4.0E-6 V	>10:1
	4.0V	- 3.2000 V	- 3.2005 V	_____	- 3.1995 V	1.1E-5 V
- 2.4000 V		- 2.4004 V	_____	- 2.3996 V	9.0E-6 V	>10:1
- 1.6000 V		- 1.6003 V	_____	- 1.5997 V	7.0E-6 V	>10:1
- 0.8000 V		- 0.8002 V	_____	- 0.7998 V	5.0E-6 V	>10:1
0.0000 V		- 0.0001 V	_____	+0.0001 V	3.0E-6 V	>10:1
+0.8000 V		+0.7998 V	_____	+0.8002 V	5.0E-6 V	>10:1
+1.6000 V		+1.5997 V	_____	+1.6003 V	7.0E-6 V	>10:1
+2.4000 V		+2.3996 V	_____	+2.4004 V	9.0E-6 V	>10:1
+3.2000 V		+3.1995 V	_____	+3.2005 V	1.1E-5 V	>10:1
16.0V		- 12.8000 V	- 12.8019 V	_____	- 12.7981 V	1.0E-4 V
	- 9.6000 V	- 9.6015 V	_____	- 9.5985 V	8.8E-5 V	>10:1
	- 6.4000 V	- 6.4012 V	_____	- 6.3988 V	7.6E-5 V	>10:1
	- 3.2000 V	- 3.2009 V	_____	- 3.1991 V	6.3E-5 V	>10:1
	0.0000 V	- 0.0006 V	_____	+ 0.0006 V	5.0E-5 V	10:1
	+ 3.2000 V	+ 3.1991 V	_____	+ 3.2009 V	6.3E-5 V	>10:1
	+ 6.4000 V	+ 6.3988 V	_____	+ 6.4012 V	7.6E-5 V	>10:1
	+ 9.6000 V	+ 9.5985 V	_____	+ 9.6015 V	8.8E-5 V	>10:1
	+12.8000 V	+12.7981 V	_____	+12.8019 V	1.0E-4 V	>10:1

Table 2-1. Performance Test Record for the HP E1415A and HP E1419A (Page 7 of 37)

Test 2-3: DCV Measurement Accuracy - E1503A Amplifier+Filter SCP (Gain X1 and 100 Hz Filter)							
Ctlr Range	Input	Minimum	Measured	Maximum	M.U.	TAR	
.0625 V	- 50.0000 mV	- 50.0141 mV	_____	- 49.9860 mV	7.5E-7 V	>10:1	
	- 37.0000 mV	- 37.0127 mV	_____	- 36.9872 mV	6.6E-7 V	>10:1	
	- 25.0000 mV	- 25.0116 mV	_____	- 24.9885 mV	5.8E-7 V	>10:1	
	- 12.0000 mV	- 12.0102 mV	_____	- 11.9898 mV	4.8E-7 V	>10:1	
	0.0000 mV	- 0.0090 mV	_____	+ 0.0090 mV	4.0E-7 V	>10:1	
	+ 12.0000 mV	+ 11.9898 mV	_____	+ 12.0102 mV	4.8E-7 V	>10:1	
	+ 25.0000 mV	+ 24.9885 mV	_____	+ 25.0116 mV	5.8E-7 V	>10:1	
	+ 37.0000 mV	+ 36.9872 mV	_____	+ 37.0127 mV	6.6E-7 V	>10:1	
	+ 50.0000 mV	+ 49.9860 mV	_____	+ 50.0141 mV	7.5E-7 V	>10:1	
	.25 V	- 200.0000 mV	- 200.0343 mV	_____	- 199.9657 mV	1.6E-6 V	>10:1
		- 150.0000 mV	- 150.0293 mV	_____	- 149.9706 mV	1.4E-6 V	>10:1
- 100.0000 mV		- 100.0244 mV	_____	- 99.9757 mV	1.2E-6 V	>10:1	
- 50.0000 mV		- 50.0194 mV	_____	- 49.9806 mV	1.0E-6 V	>10:1	
0.0000 mV		- 0.0144 mV	_____	+ 0.0144 mV	8.0E-7 V	>10:1	
+ 50.0000 mV		+ 49.9806 mV	_____	+ 50.0194 mV	1.0E-6 V	>10:1	
+100.0000 mV		+ 99.9757 mV	_____	+100.0244 mV	1.2E-6 V	>10:1	
+150.0000 mV		+149.9706 mV	_____	+150.0293 mV	1.4E-6 V	>10:1	
+200.0000 mV		+199.9657 mV	_____	+200.0343 mV	1.6E-6 V	>10:1	
1.0V		- 800.0000 mV	- 800.1169 mV	_____	- 799.8831 mV	4.0E-6 V	>10:1
		- 600.0000 mV	- 600.0969 mV	_____	- 599.9031 mV	3.2E-6 V	>10:1
	- 400.0000 mV	- 400.0769 mV	_____	- 399.9231 mV	2.4E-6 V	>10:1	
	- 200.0000 mV	- 200.0569 mV	_____	- 199.9431 mV	1.6E-6 V	>10:1	
	0.0000 mV	- 0.0369 mV	_____	+ 0.0369 mV	0.8E-6 V	>10:1	
	+200.0000 mV	+199.9431 mV	_____	+200.0569 mV	1.6E-6 V	>10:1	
	+400.0000 mV	+399.9231 mV	_____	+400.0769 mV	2.4E-6 V	>10:1	
	+600.0000 mV	+599.9031 mV	_____	+600.0969 mV	3.2E-6 V	>10:1	
	+800.0000 mV	+799.8831 mV	_____	+800.1169 mV	4.0E-6 V	>10:1	
	4.0V	- 3.2000 V	- 3.2005 V	_____	- 3.1995 V	1.1E-5 V	>10:1
		- 2.4000 V	- 2.4004 V	_____	- 2.3996 V	9.0E-6 V	>10:1
- 1.6000 V		- 1.6003 V	_____	- 1.5997 V	7.0E-6 V	>10:1	
- 0.8000 V		- 0.8002 V	_____	- 0.7998 V	5.0E-6 V	>10:1	
0.0000 V		- 0.0001 V	_____	+0.0001 V	3.0E-6 V	>10:1	
+0.8000 V		+0.7998 V	_____	+0.8002 V	5.0E-6 V	>10:1	
+1.6000 V		+1.5997 V	_____	+1.6003 V	7.0E-6 V	>10:1	
+2.4000 V		+2.3996 V	_____	+2.4004 V	9.0E-6 V	>10:1	
+3.2000 V		+3.1995 V	_____	+3.2005 V	1.1E-5 V	>10:1	
16.0V		- 12.8000 V	- 12.8019 V	_____	- 12.7981 V	1.0E-4	>10:1
		- 9.6000 V	- 9.6015 V	_____	- 9.5985 V	8.8E-5	>10:1
	- 6.4000 V	- 6.4012 V	_____	- 6.3988 V	7.6E-5	>10:1	
	- 3.2000 V	- 3.2009 V	_____	- 3.1991 V	6.3E-5	>10:1	
	0.0000 V	- 0.0006 V	_____	+ 0.0006 V	5.0E-5	>10:1	
	+ 3.2000 V	+ 3.1991 V	_____	+ 3.2009 V	6.3E-5	>10:1	
	+ 6.4000 V	+ 6.3988 V	_____	+ 6.4012 V	7.6E-5	>10:1	
	+ 9.6000 V	+ 9.5985 V	_____	+ 9.6015 V	8.8E-5	>10:1	
	+12.8000 V	+12.7981 V	_____	+12.8019 V	1.0E-4	>10:1	

Table 2-1. Performance Test Record for the HP E1415A and HP E1419A (Page 8 of 37)

Test 2-3: DCV Measurement Accuracy - E1503A Amplifier+Filter Input SCP (Gain X1, Filter OFF)						
Ctlr Range	Input	Minimum	Measured	Maximum	M.U.	TAR
.0625 V	- 50.0000 mV	- 50.0136 mV	_____	- 49.9864 mV	7.5E-7 V	>10:1
	- 37.0000 mV	- 37.0122 mV	_____	- 36.9877 mV	6.6E-7 V	>10:1
	- 25.0000 mV	- 25.0111 mV	_____	- 24.9890 mV	5.8E-7 V	>10:1
	- 12.0000 mV	- 12.0097 mV	_____	- 11.9903 mV	4.8E-7 V	>10:1
	0.0000 mV	- 0.0085 mV	_____	+ 0.0085 mV	4.0E-7 V	>10:1
	+ 12.0000 mV	+ 11.9903 mV	_____	+ 12.0097 mV	4.8E-7 V	>10:1
	+ 25.0000 mV	+ 24.9890 mV	_____	+ 25.0111 mV	5.8E-7 V	>10:1
	+ 37.0000 mV	+ 36.9877 mV	_____	+ 37.0122 mV	6.6E-7 V	>10:1
	+ 50.0000 mV	+ 49.9864 mV	_____	+ 50.0136 mV	7.5E-7 V	>10:1
	.25 V	- 200.0000 mV	- 200.0340 mV	_____	- 199.9661 mV	1.6E-6 V
- 150.0000 mV		- 150.0289 mV	_____	- 149.9710 mV	1.4E-6 V	>10:1
- 100.0000 mV		- 100.0240 mV	_____	- 99.9761 mV	1.2E-6 V	>10:1
- 50.0000 mV		- 50.0189 mV	_____	- 49.9811 mV	1.0E-6 V	>10:1
0.0000 mV		- 0.0140 mV	_____	+ 0.0140 mV	8.0E-7 V	>10:1
+ 50.0000 mV		+ 49.9811 mV	_____	+ 50.0189 mV	1.0E-6 V	>10:1
+100.0000 mV		+ 99.9761 mV	_____	+100.0240 mV	1.2E-6 V	>10:1
+150.0000 mV		+149.9710 mV	_____	+150.0289 mV	1.4E-6 V	>10:1
+200.0000 mV		+199.9661 mV	_____	+200.0340 mV	1.6E-6 V	>10:1
1.0V		- 800.0000 mV	- 800.1168 mV	_____	- 799.8832 mV	4.0E-6 V
	- 600.0000 mV	- 600.0968 mV	_____	- 599.9032 mV	3.2E-6 V	>10:1
	- 400.0000 mV	- 400.0768 mV	_____	- 399.9232 mV	2.4E-6 V	>10:1
	- 200.0000 mV	- 200.0568 mV	_____	- 199.9432 mV	1.6E-6 V	>10:1
	0.0000 mV	- 0.0368 mV	_____	+ 0.0368 mV	0.8E-6 V	>10:1
	+200.0000 mV	+199.9432 mV	_____	+200.0568 mV	1.6E-6 V	>10:1
	+400.0000 mV	+399.9232 mV	_____	+400.0768 mV	2.4E-6 V	>10:1
	+600.0000 mV	+599.9032 mV	_____	+600.0968 mV	3.2E-6 V	>10:1
	+800.0000 mV	+799.8832 mV	_____	+800.1168 mV	4.0E-6 V	>10:1
	4.0V	- 3.2000 V	- 3.2005 V	_____	- 3.1995 V	1.1E-5 V
- 2.4000 V		- 2.4004 V	_____	- 2.3996 V	9.0E-6 V	>10:1
- 1.6000 V		- 1.6003 V	_____	- 1.5997 V	7.0E-6 V	>10:1
- 0.8000 V		- 0.8002 V	_____	- 0.7998 V	5.0E-6 V	>10:1
0.0000 V		- 0.0001 V	_____	+0.0001 V	3.0E-6 V	>10:1
+0.8000 V		+0.7998 V	_____	+0.8002 V	5.0E-6 V	>10:1
+1.6000 V		+1.5997 V	_____	+1.6003 V	7.0E-6 V	>10:1
+2.4000 V		+2.3996 V	_____	+2.4004 V	9.0E-6 V	>10:1
+3.2000 V		+3.1995 V	_____	+3.2005 V	1.1E-5 V	>10:1
16.0V		- 12.8000 V	- 12.8019 V	_____	- 12.7981 V	1.0E-4
	- 9.6000 V	- 9.6015 V	_____	- 9.5985 V	8.8E-5	>10:1
	- 6.4000 V	- 6.4012 V	_____	- 6.3988 V	7.6E-5	>10:1
	- 3.2000 V	- 3.2009 V	_____	- 3.1991 V	6.3E-5	>10:1
	0.0000 V	- 0.0006 V	_____	+ 0.0006 V	5.0E-5	10:1
	+ 3.2000 V	+ 3.1991 V	_____	+ 3.2009 V	6.3E-5	>10:1
	+ 6.4000 V	+ 6.3988 V	_____	+ 6.4012 V	7.6E-5	>10:1
	+ 9.6000 V	+ 9.5985 V	_____	+ 9.6015 V	8.8E-5	>10:1
	+12.8000 V	+12.7981 V	_____	+12.8019 V	1.0E-4	>10:1

Table 2-1. Performance Test Record for the HP E1415A and HP E1419A (Page 9 of 37)

Test 2-4: DCV Measurement Accuracy - E1503A Amplifier+Filter SCP (Gain X8 and 2 Hz Filter)						
Ctlr Range	Input	Minimum	Measured	Maximum	M.U.	TAR
.0625 V	- 6.0000 mV	- 6.0055 mV	_____	- 5.9945 mV	4.4E-7 V	>10:1
	- 4.5000 mV	- 4.5053 mV	_____	- 4.4947 mV	4.3E-7 V	>10:1
	- 3.0000 mV	- 3.0052 mV	_____	- 2.9948 mV	4.2E-7 V	>10:1
	- 1.5000 mV	- 1.5050 mV	_____	- 1.4950 mV	4.1E-7 V	>10:1
	0.0000 mV	- 0.0049 mV	_____	+ 0.0049 mV	4.0E-7 V	>10:1
	+ 1.5000 mV	+ 1.4950 mV	_____	+ 1.5050 mV	4.1E-7 V	>10:1
	+ 3.0000 mV	+ 2.9948 mV	_____	+ 3.0052 mV	4.2E-7 V	>10:1
	+ 4.5000 mV	+ 4.4947 mV	_____	+ 4.5053 mV	4.3E-7 V	>10:1
	+ 6.0000 mV	+ 5.9945 mV	_____	+ 6.0055 mV	4.4E-7 V	>10:1
	.25 V	- 25.0000 mV	- 25.0076 mV	_____	- 24.9924 mV	5.8E-7 V
- 18.0000 mV		- 18.0069 mV	_____	- 17.9931 mV	5.3E-7 V	>10:1
- 12.0000 mV		- 12.0063 mV	_____	- 11.9937 mV	4.8E-7 V	>10:1
- 6.0000 mV		- 6.0057 mV	_____	- 5.9943 mV	4.4E-7 V	>10:1
0.0000 mV		- 0.0051 mV	_____	+ 0.0051 mV	4.0E-7 V	>10:1
+ 6.0000 mV		+ 5.9943 mV	_____	+ 6.0057 mV	4.4E-7 V	>10:1
+12.0000 mV		+ 11.9937 mV	_____	+ 12.0063 mV	4.8E-7 V	>10:1
+18.0000 mV		+ 17.9931 mV	_____	+ 18.0069 mV	5.3E-7 V	>10:1
+25.0000 mV		+ 24.9924 mV	_____	+ 25.0076 mV	5.8E-7 V	>10:1
1.0V		- 100.000 mV	- 100.017 mV	_____	- 99.983 mV	1.2E-6 V
	- 75.000 mV	- 75.014 mV	_____	- 74.986 mV	1.1E-6 V	>10:1
	- 50.000 mV	- 50.012 mV	_____	- 49.988 mV	1.0E-6 V	>10:1
	- 25.000 mV	- 25.009 mV	_____	- 24.991 mV	9.0E-7 V	9:1
	0.000 mV	- 0.007 mV	_____	+ 0.007 mV	8.0E-7 V	8:1
	+ 25.000 mV	+ 24.991 mV	_____	+ 25.009 mV	9.0E-7 V	9:1
	+ 50.000 mV	+ 49.988 mV	_____	+ 50.012 mV	1.0E-6 V	>10:1
	+ 75.000 mV	+ 74.986 mV	_____	+ 75.014 mV	1.1E-6 V	>10:1
	+100.000 mV	+ 99.983 mV	_____	+100.017 mV	1.2E-6 V	>10:1
	4.0V	- 400.000 mV	- 400.059 mV	_____	- 399.941 mV	2.4E-6 V
- 300.000 mV		- 300.049 mV	_____	- 299.951 mV	2.0E-6 V	>10:1
- 200.000 mV		- 200.039 mV	_____	- 199.961 mV	1.6E-6 V	>10:1
- 100.000 mV		- 100.029 mV	_____	- 99.971 mV	1.2E-6 V	>10:1
0.000 mV		- 0.019 mV	_____	+ 0.019 mV	8.0E-7 V	>10:1
+100.000 mV		+ 99.971 mV	_____	+100.029 mV	1.2E-6 V	>10:1
+200.000 mV		+199.961 mV	_____	+200.039 mV	1.6E-6 V	>10:1
+300.000 mV		+299.951 mV	_____	+300.049 mV	2.0E-6 V	>10:1
+400.000 mV		+399.941 mV	_____	+400.059 mV	2.4E-6 V	>10:1
16.0V		- 1.6000 V	- 1.6002 V	_____	- 1.5998 V	7.0E-6 V
	- 1.2000 V	- 1.2002 V	_____	- 1.1998 V	6.0E-6 V	>10:1
	- 0.8000 V	- 0.8002 V	_____	- 0.7998 V	5.0E-6 V	>10:1
	- 0.4000 V	- 0.4001 V	_____	- 0.3999 V	4.0E-6 V	>10:1
	0.0000 V	- 0.0001 V	_____	+0.0001 V	3.0E-6 V	>10:1
	+0.4000 V	+0.3999 V	_____	+0.4001 V	4.0E-6 V	>10:1
	+0.8000 V	+0.7998 V	_____	+0.8002 V	5.0E-6 V	>10:1
	+1.2000 V	+1.1998 V	_____	+1.2002 V	6.0E-6 V	>10:1
	+1.6000 V	+1.5998 V	_____	+1.6002 V	7.0E-6 V	>10:1

Table 2-1. Performance Test Record for the HP E1415A and HP E1419A (Page 10 of 37)

Test 2-4: DCV Measurement Accuracy - E1503A Amplifier+Filter SCP (Gain X8 and 10 Hz Filter)						
Ctlr Range	Input	Minimum	Measured	Maximum	M.U.	TAR
.0625 V	- 6.0000 mV	- 6.0051 mV	_____	- 5.9949 mV	4.4E-7 V	>10:1
	- 4.5000 mV	- 4.5049 mV	_____	- 4.4951 mV	4.3E-7 V	>10:1
	- 3.0000 mV	- 3.0048 mV	_____	- 2.9952 mV	4.2E-7 V	>10:1
	- 1.5000 mV	- 1.5046 mV	_____	- 1.4954 mV	4.1E-7 V	>10:1
	0.0000 mV	- 0.0045 mV	_____	+ 0.0045 mV	4.0E-7 V	>10:1
	+ 1.5000 mV	+ 1.4954 mV	_____	+ 1.5046 mV	4.1E-7 V	>10:1
	+ 3.0000 mV	+ 2.9952 mV	_____	+ 3.0048 mV	4.2E-7 V	>10:1
	+ 4.5000 mV	+ 4.4951 mV	_____	+ 4.5049 mV	4.3E-7 V	>10:1
	+ 6.0000 mV	+ 5.9949 mV	_____	+ 6.0051 mV	4.4E-7 V	>10:1
	.25 V	- 25.0000 mV	- 25.0074 mV	_____	- 24.9926 mV	5.8E-7 V
- 18.0000 mV		- 18.0067 mV	_____	- 17.9933 mV	5.3E-7 V	>10:1
- 12.0000 mV		- 12.0061 mV	_____	- 11.9939 mV	4.8E-7 V	>10:1
- 6.0000 mV		- 6.0055 mV	_____	- 5.9958 mV	4.4E-7 V	>10:1
0.0000 mV		- 0.0049 mV	_____	+ 0.0049 mV	4.0E-7 V	>10:1
+ 6.0000 mV		+ 5.9945 mV	_____	+ 6.0055 mV	4.4E-7 V	>10:1
+12.0000 mV		+ 11.9939 mV	_____	+ 12.0061 mV	4.8E-7 V	>10:1
+18.0000 mV		+ 17.9933 mV	_____	+ 18.0067 mV	5.3E-7 V	>10:1
+25.0000 mV		+ 24.9926 mV	_____	+ 25.0074 mV	5.8E-7 V	>10:1
1.0V		- 100.800 mV	- 100.016 mV	_____	- 99.984 mV	1.2E-6 V
	- 75.000 mV	- 75.014 mV	_____	- 74.987 mV	1.1E-6 V	>10:1
	- 50.000 mV	- 50.011 mV	_____	- 49.989 mV	1.0E-6 V	10:1
	- 25.000 mV	- 25.009 mV	_____	- 24.992 mV	9.0E-7 V	9:1
	0.000 mV	- 0.006 mV	_____	+ 0.006 mV	8.0E-7 V	7:1
	+ 25.000 mV	+ 24.992 mV	_____	+ 25.009 mV	9.0E-7 V	9:1
	+ 50.000 mV	+ 49.989 mV	_____	+ 50.011 mV	1.0E-6 V	10:1
	+ 75.000 mV	+ 74.987 mV	_____	+ 75.014 mV	1.1E-6 V	>10:1
	+100.000 mV	+ 99.984 mV	_____	+100.016 mV	1.2E-6 V	>10:1
	4.0V	- 400.000 mV	- 400.059 mV	_____	- 399.941 mV	2.4E-6 V
- 300.000 mV		- 300.049 mV	_____	- 299.951 mV	2.0E-6 V	>10:1
- 200.000 mV		- 200.039 mV	_____	- 199.961 mV	1.6E-6 V	>10:1
- 100.000 mV		- 100.029 mV	_____	- 99.971 mV	1.2E-6 V	>10:1
0.000 mV		- 0.019 mV	_____	+ 0.019 mV	8.0E-7 V	>10:1
+100.000 mV		+ 99.971 mV	_____	+100.029 mV	1.2E-6 V	>10:1
+200.000 mV		+199.961 mV	_____	+200.039 mV	1.6E-6 V	>10:1
+300.000 mV		+299.951 mV	_____	+300.049 mV	2.0E-6 V	>10:1
+400.000 mV		+399.941 mV	_____	+400.059 mV	2.4E-6 V	>10:1
16.0V		- 1.6000 V	- 1.6002 V	_____	- 1.5998 V	7.0E-6 V
	- 1.2000 V	- 1.2002 V	_____	- 1.1998 V	6.0E-6 V	>10:1
	- 0.8000 V	- 0.8002 V	_____	- 0.7998 V	5.0E-6 V	>10:1
	- 0.4000 V	- 0.4001 V	_____	- 0.3999 V	4.0E-6 V	>10:1
	0.0000 V	- 0.0001 V	_____	+0.0001 V	3.0E-6 V	>10:1
	+0.4000 V	+0.3999 V	_____	+0.4001 V	4.0E-6 V	>10:1
	+0.8000 V	+0.7998 V	_____	+0.8002 V	5.0E-6 V	>10:1
	+1.2000 V	+1.1998 V	_____	+1.2002 V	6.0E-6 V	>10:1
	+1.6000 V	+1.5998 V	_____	+1.6002 V	7.0E-6 V	>10:1

Table 2-1. Performance Test Record for the HP E1415A and HP E1419A (Page 11 of 37)

Test 2-4: DCV Measurement Accuracy - E1503A Amplifier+Filter SCP (Gain X8 and 100 Hz Filter)						
Ctlr Range	Input	Minimum	Measured	Maximum	M.U.	TAR
.0625 V	- 6.0000 mV	- 6.0047 mV	_____	- 5.9953 mV	4.4E-7 V	10:1
	- 4.5000 mV	- 4.5045 mV	_____	- 4.4955 mV	4.3E-7 V	10:1
	- 3.0000 mV	- 3.0044 mV	_____	- 2.9956 mV	4.2E-7 V	10:1
	- 1.5000 mV	- 1.5042 mV	_____	- 1.4958 mV	4.1E-7 V	10:1
	0.0000 mV	- 0.0041 mV	_____	+ 0.0041 mV	4.0E-7 V	10:1
	+ 1.5000 mV	+ 1.4958 mV	_____	+ 1.5042 mV	4.1E-7 V	10:1
	+ 3.0000 mV	+ 2.9956 mV	_____	+ 3.0044 mV	4.2E-7 V	10:1
	+ 4.5000 mV	+ 4.4955 mV	_____	+ 4.5045 mV	4.3E-7 V	10:1
	+ 6.0000 mV	+ 5.9953 mV	_____	+ 6.0047 mV	4.4E-7 V	10:1
	.25 V	- 25.0000 mV	- 25.0072 mV	_____	- 24.9928 mV	5.8E-7 V
- 18.0000 mV		- 18.0065 mV	_____	- 17.9935 mV	5.3E-7 V	>10:1
- 12.0000 mV		- 12.0059 mV	_____	- 11.9941 mV	4.8E-7 V	>10:1
- 6.0000 mV		- 6.0053 mV	_____	- 5.9947 mV	4.4E-7 V	>10:1
0.0000 mV		- 0.0047 mV	_____	+ 0.0047 mV	4.0E-7 V	>10:1
+ 6.0000 mV		+ 5.9947 mV	_____	+ 6.0053 mV	4.4E-7 V	>10:1
+12.0000 mV		+ 11.9941 mV	_____	+ 12.0059 mV	4.8E-7 V	>10:1
+18.0000 mV		+ 17.9935 mV	_____	+ 18.0065 mV	5.3E-7 V	>10:1
+25.0000 mV		+ 24.9928 mV	_____	+ 25.0072 mV	5.8E-7 V	>10:1
1.0V		- 100.000 mV	- 100.016 mV	_____	- 99.984 mV	1.2E-6 V
	- 75.000 mV	- 75.013 mV	_____	- 74.987 mV	1.1E-6 V	>10:1
	- 50.000 mV	- 50.011 mV	_____	- 49.989 mV	1.0E-6 V	10:1
	- 25.000 mV	- 25.008 mV	_____	- 24.992 mV	9.0E-7 V	8:1
	0.000 mV	- 0.006 mV	_____	+ 0.006 mV	8.0E-7 V	6:1
	+ 25.000 mV	+ 24.992 mV	_____	+ 25.008 mV	9.0E-7 V	8:1
	+ 50.000 mV	+ 49.989 mV	_____	+ 50.011 mV	1.0E-6 V	10:1
	+ 75.000 mV	+ 74.987 mV	_____	+ 75.013 mV	1.1E-6 V	>10:1
	+100.000 mV	+ 99.984 mV	_____	+100.016 mV	1.2E-6 V	>10:1
	4.0V	- 400.000 mV	- 400.059 mV	_____	- 399.941 mV	2.4E-6 V
- 300.000 mV		- 300.049 mV	_____	- 299.951 mV	2.0E-6 V	>10:1
- 200.000 mV		- 200.039 mV	_____	- 199.961 mV	1.6E-6 V	>10:1
- 100.000 mV		- 100.029 mV	_____	- 99.971 mV	1.2E-6 V	>10:1
0.000 mV		- 0.019 mV	_____	+ 0.019 mV	8.0E-7 V	>10:1
+100.000 mV		+ 99.971 mV	_____	+100.029 mV	1.2E-6 V	>10:1
+200.000 mV		+199.961 mV	_____	+200.039 mV	1.6E-6 V	>10:1
+300.000 mV		+299.951 mV	_____	+300.049 mV	2.0E-6 V	>10:1
+400.000 mV		+399.941 mV	_____	+400.059 mV	2.4E-6 V	>10:1
16.0V		- 1.6000 V	- 1.6002 V	_____	- 1.5998 V	7.0E-6 V
	- 1.2000 V	- 1.2002 V	_____	- 1.1998 V	6.0E-6 V	>10:1
	- 0.8000 V	- 0.8002 V	_____	- 0.7999 V	5.0E-6 V	>10:1
	- 0.4000 V	- 0.4001 V	_____	- 0.3999 V	4.0E-6 V	>10:1
	0.0000 V	- 0.0001 V	_____	+0.0001 V	3.0E-6 V	>10:1
	+0.4000 V	+0.3999 V	_____	+0.4001 V	4.0E-6 V	>10:1
	+0.8000 V	+0.7999 V	_____	+0.8002 V	5.0E-6 V	>10:1
	+1.2000 V	+1.1998 V	_____	+1.2002 V	6.0E-6 V	>10:1
	+1.6000 V	+1.5998 V	_____	+1.6002 V	7.0E-6 V	>10:1

Table 2-1. Performance Test Record for the HP E1415A and HP E1419A (Page 12 of 37)

Test 2-4: DCV Measurement Accuracy - E1503A Amplifier+Filter SCP (Gain X8 and Filter OFF)						
Ctlr Range	Input	Minimum	Measured	Maximum	M.U.	TAR
.0625 V	- 6.0000 mV	- 6.0046 mV	_____	- 5.9954 mV	4.4E-7 V	10:1
	- 4.5000 mV	- 4.5044 mV	_____	- 4.4956 mV	4.3E-7 V	10:1
	- 3.0000 mV	- 3.0043 mV	_____	- 2.9957 mV	4.2E-7 V	10:1
	- 1.5000 mV	- 1.5041 mV	_____	- 1.4959 mV	4.1E-7 V	9:1
	0.0000 mV	- 0.0040 mV	_____	+ 0.0040 mV	4.0E-7 V	9:1
	+ 1.5000 mV	+ 1.4959 mV	_____	+ 1.5041 mV	4.1E-7 V	9:1
	+ 3.0000 mV	+ 2.9957 mV	_____	+ 3.0043 mV	4.2E-7 V	10:1
	+ 4.5000 mV	+ 4.4956 mV	_____	+ 4.5044 mV	4.3E-7 V	10:1
	+ 6.0000 mV	+ 5.9954 mV	_____	+ 6.0046 mV	4.4E-7 V	10:1
	.25 V	- 25.0000 mV	- 25.0071 mV	_____	- 24.9929 mV	5.8E-7 V
- 18.0000 mV		- 18.0064 mV	_____	- 17.9936 mV	5.3E-7 V	>10:1
- 12.0000 mV		- 12.0058 mV	_____	- 11.9942 mV	4.8E-7 V	>10:1
- 6.0000 mV		- 6.0052 mV	_____	- 5.9948 mV	4.4E-7 V	>10:1
0.0000 mV		- 0.0046 mV	_____	+ 0.0046 mV	4.0E-7 V	>10:1
+ 6.0000 mV		+ 5.9948 mV	_____	+ 6.0052 mV	4.4E-7 V	>10:1
+12.0000 mV		+ 11.9942 mV	_____	+ 12.0058 mV	4.8E-7 V	>10:1
+18.0000 mV		+ 17.9936 mV	_____	+ 18.0064 mV	5.3E-7 V	>10:1
+25.0000 mV		+ 24.9929 mV	_____	+ 25.0071 mV	5.8E-7 V	>10:1
1.0V		- 100.000 mV	- 100.016 mV	_____	- 99.984 mV	1.2E-6 V
	- 75.000 mV	- 75.013 mV	_____	- 74.987 mV	1.1E-6 V	>10:1
	- 50.000 mV	- 50.011 mV	_____	- 49.989 mV	1.0E-6 V	10:1
	- 25.000 mV	- 25.008 mV	_____	- 24.992 mV	9.0E-7 V	8:1
	0.000 mV	- 0.006 mV	_____	+ 0.006 mV	8.0E-7 V	6:1
	+ 25.000 mV	+ 24.992 mV	_____	+ 25.008 mV	9.0E-7 V	8:1
	+ 50.000 mV	+ 49.989 mV	_____	+ 50.011 mV	1.0E-6 V	10:1
	+ 75.000 mV	+ 74.987 mV	_____	+ 75.013 mV	1.1E-6 V	>10:1
	+100.000 mV	+ 99.984 mV	_____	+100.016 mV	1.2E-6 V	>10:1
	4.0V	- 400.000 mV	- 400.059 mV	_____	- 399.941 mV	2.4E-6 V
- 300.000 mV		- 300.049 mV	_____	- 299.951 mV	2.0E-6 V	>10:1
- 200.000 mV		- 200.039 mV	_____	- 199.961 mV	1.6E-6 V	>10:1
- 100.000 mV		- 100.029 mV	_____	- 99.971 mV	1.2E-6 V	>10:1
0.000 mV		- 0.019 mV	_____	+ 0.019 mV	8.0E-7 V	>10:1
+100.000 mV		+ 99.971 mV	_____	+100.029 mV	1.2E-6 V	>10:1
+200.000 mV		+199.961 mV	_____	+200.039 mV	1.6E-6 V	>10:1
+300.000 mV		+299.951 mV	_____	+300.049 mV	2.0E-6 V	>10:1
+400.000 mV		+399.941 mV	_____	+400.059 mV	2.4E-6 V	>10:1
16.0V		- 1.6000 V	- 1.6002 V	_____	- 1.5998 V	7.0E-6 V
	- 1.2000 V	- 1.2002 V	_____	- 1.1998 V	6.0E-6 V	>10:1
	- 0.8000 V	- 0.8002 V	_____	- 0.7999 V	5.0E-6 V	>10:1
	- 0.4000 V	- 0.4001 V	_____	- 0.3999 V	4.0E-6 V	>10:1
	0.0000 V	- 0.0001 V	_____	+0.0001 V	3.0E-6 V	>10:1
	+0.4000 V	+0.3999 V	_____	+0.4001 V	4.0E-6 V	>10:1
	+0.8000 V	+0.7999 V	_____	+0.8002 V	5.0E-6 V	>10:1
	+1.2000 V	+1.1998 V	_____	+1.2002 V	6.0E-6 V	>10:1
	+1.6000 V	+1.5998 V	_____	+1.6002 V	7.0E-6 V	>10:1

Table 2-1. Performance Test Record for the HP E1415A and HP E1419A (Page 13 of 37)

Test 2-5: DCV Measurement Accuracy - E1503A Amplifier+Filter SCP (Gain X64 and 2 Hz Filter)						
Ctrl Range	Input	Minimum	Measured	Maximum	M.U.	TAR
.25 V	- 3.0000 mV	- 3.0033 mV	_____	- 2.9967 mV	4.2E-7 V	8:1
	- 2.5000 mV	- 2.5032 mV	_____	- 2.4968 mV	4.2E-7 V	8:1
	- 1.5000 mV	- 1.5031 mV	_____	- 1.4969 mV	4.1E-7 V	7:1
	- 0.8000 mV	- 0.8031 mV	_____	- 0.7969 mV	4.1E-7 V	7:1
	0.0000 mV	- 0.0030 mV	_____	+0.0030 mV	4.0E-7 V	7:1
	+0.8000 mV	+0.7969 mV	_____	+0.8031 mV	4.1E-7 V	7:1
	+1.5000 mV	+1.4969 mV	_____	+1.5031 mV	4.1E-7 V	7:1
	+2.5000 mV	+2.4968 mV	_____	+2.5032 mV	4.2E-7 V	8:1
	+3.0000 mV	+2.9967 mV	_____	+3.0033 mV	4.2E-7 V	8:1
	1.0V	- 12.8000 mV	- 12.8044 mV	_____	- 12.7956 mV	4.9E-7 V
- 9.6000 mV		- 9.6041 mV	_____	- 9.5959 mV	4.7E-7 V	8:1
- 6.4000 mV		- 6.4038 mV	_____	- 6.3963 mV	4.4E-7 V	8:1
- 3.2000 mV		- 3.2034 mV	_____	- 3.1966 mV	4.2E-7 V	8:1
0.0000 mV		- 0.0031 mV	_____	+ 0.0031 mV	4.0E-7 V	8:1
+ 3.2000 mV		+ 3.1966 mV	_____	+ 3.2034 mV	4.2E-7 V	8:1
+ 6.4000 mV		+ 6.3963 mV	_____	+ 6.4038 mV	4.4E-7 V	8:1
+ 9.6000 mV		+ 9.5959 mV	_____	+ 9.6041 mV	4.7E-7 V	8:1
+12.8000 mV		+12.7956 mV	_____	+12.8044 mV	4.9E-7 V	9:1
4.0V		- 50.0000 mV	- 50.0089 mV	_____	- 49.9912 mV	7.5E-7 V
	- 37.5000 mV	- 37.5063 mV	_____	- 37.4924 mV	6.6E-7 V	>10:1
	- 25.0000 mV	- 25.0064 mV	_____	- 24.9937 mV	5.8E-7 V	10:1
	- 12.5000 mV	- 12.5051 mV	_____	- 12.4949 mV	4.9E-7 V	10:1
	0.0000 mV	- 0.0038 mV	_____	+ 0.0038 mV	4.0E-7 V	9:1
	+12.5000 mV	+12.4949 mV	_____	+12.5051 mV	4.9E-7 V	10:1
	+25.0000 mV	+24.9937 mV	_____	+25.0064 mV	5.8E-7 V	10:1
	+37.5000 mV	+37.4924 mV	_____	+37.5076 mV	6.6E-7 V	>10:1
	+50.0000 mV	+49.9912 mV	_____	+50.0089 mV	7.5E-7 V	>10:1
	16.0V	- 200.0000 mV	- 200.0296 mV	_____	- 199.9704 mV	1.6E-6 V
- 150.0000 mV		- 150.0246 mV	_____	- 149.9754 mV	1.4E-6 V	>10:1
- 100.0000 mV		- 100.0196 mV	_____	- 99.9804 mV	1.2E-6 V	>10:1
- 50.0000 mV		- 50.0146 mV	_____	- 49.9854 mV	1.0E-6 V	>10:1
0.0000 mV		- 0.0096 mV	_____	+ 0.0096 mV	0.8E-6 V	10:1
+ 50.0000 mV		+ 49.9854 mV	_____	+ 50.0146 mV	1.0E-6 V	>10:1
+100.0000 mV		+ 99.9804 mV	_____	+100.0196 mV	1.2E-6V	>10:1
+150.0000 mV		+149.9754 mV	_____	+150.0246 mV	1.4E-6 V	>10:1
+200.0000 mV		+199.9704 mV	_____	+200.0296 mV	1.6E-6 V	>10:1

Table 2-1. Performance Test Record for the HP E1415A and HP E1419A (Page 14 of 37)

Test 2-5: DCV Measurement Accuracy - E1503A Amplifier+Filter SCP (Gain X64 and 10 Hz Filter)						
Ctlr Range	Input	Minimum	Measured	Maximum	M.U.	TAR
.25 V	- 3.0000 mV	- 3.0027 mV	_____	- 2.9973 mV	4.2E-7 V	6:1
	- 2.5000 mV	- 2.5026 mV	_____	- 2.4974 mV	4.2E-7 V	6:1
	- 1.5000 mV	- 1.5025 mV	_____	- 1.4975 mV	4.1E-7 V	6:1
	- 0.8000 mV	- 0.8025 mV	_____	- 0.7975 mV	4.1E-7 V	6:1
	0.0000 mV	- 0.0024 mV	_____	+0.0024 mV	4.0E-7 V	6:1
	+0.8000 mV	+0.7975 mV	_____	+0.8025 mV	4.1E-7 V	6:1
	+1.5000 mV	+1.4975 mV	_____	+1.5025 mV	4.1E-7 V	6:1
	+2.5000 mV	+2.4974 mV	_____	+2.5026 mV	4.2E-7 V	6:1
	+3.0000 mV	+2.9973 mV	_____	+3.0027 mV	4.2E-7 V	6:1
	1.0V	- 12.8000 mV	- 12.8038 mV	_____	- 12.7962 mV	4.9E-7 V
- 9.6000 mV		- 9.6035 mV	_____	- 9.5965 mV	4.7E-7 V	7:1
- 6.4000 mV		- 6.4032 mV	_____	- 6.3968 mV	4.4E-7 V	7:1
- 3.2000 mV		- 3.2028 mV	_____	- 3.1972 mV	4.2E-7 V	6:1
0.0000 mV		- 0.0025 mV	_____	+ 0.0025 mV	4.0E-7 V	6:1
+ 3.2000 mV		+ 3.1972 mV	_____	+ 3.2028 mV	4.2E-7 V	6:1
+ 6.4000 mV		+ 6.3968 mV	_____	+ 6.4032 mV	4.4E-7 V	7:1
+ 9.6000 mV		+ 9.5965 mV	_____	+ 9.6035 mV	4.7E-7 V	7:1
+12.8000 mV		+12.7962 mV	_____	+12.8038 mV	4.9E-7 V	8:1
4.0V		- 50.0000 mV	- 50.0084 mV	_____	- 49.9917 mV	7.5E-7 V
	- 37.5000 mV	- 37.5071 mV	_____	- 37.4929 mV	6.6E-7 V	10:1
	- 25.0000 mV	- 25.0059 mV	_____	- 24.9941 mV	5.8E-7 V	10:1
	- 12.5000 mV	- 12.5046 mV	_____	- 12.4954 mV	4.9E-7 V	9:1
	0.0000 mV	- 0.0034 mV	_____	+ 0.0034 mV	4.0E-7 V	8:1
	+12.5000 mV	+12.4954 mV	_____	+12.5046 mV	4.9E-7 V	9:1
	+25.0000 mV	+24.9941 mV	_____	+25.0059 mV	5.8E-7 V	10:1
	+37.5000 mV	+37.4929 mV	_____	+37.5071 mV	6.6E-7 V	10:1
	+50.0000 mV	+49.9917 mV	_____	+50.0084 mV	7.5E-7 V	>10:1
	16.0V	- 200.0000 mV	- 200.029 mV	_____	- 199.971 mV	1.2E-6 V
- 150.0000 mV		- 150.024 mV	_____	- 149.976 mV	1.0E-6 V	>10:1
- 100.0000 mV		- 100.019 mV	_____	- 99.981 mV	8.0E-7 V	>10:1
- 50.0000 mV		- 50.014 mV	_____	- 49.986 mV	6.0E-7 V	>10:1
0.0000 mV		- 0.009 mV	_____	+ 0.009 mV	4.0E-7 V	10:1
+ 50.0000 mV		+ 49.986 mV	_____	+ 50.014 mV	6.0E-7 V	>10:1
+100.0000 mV		+ 99.981 mV	_____	+100.019 mV	8.0E-7 V	>10:1
+150.0000 mV		+149.976 mV	_____	+150.024 mV	1.0E-6 V	>10:1
+200.0000 mV		+199.971 mV	_____	+200.029 mV	1.2E-6 V	>10:1

Table 2-1. Performance Test Record for the HP E1415A and HP E1419A (Page 15 of 37)

Test 2-5: DCV Measurement Accuracy - E1503A Amplifier+Filter SCP (Gain X64 and 100 Hz Filter)						
Ctrl Range	Input	Minimum	Measured	Maximum	M.U.	TAR
.25 V	- 3.0000 mV	- 3.0025 mV	_____	- 2.9975 mV	4.2E-7 V	6:1
	- 2.5000 mV	- 2.5024 mV	_____	- 2.4976 mV	4.2E-7 V	6:1
	- 1.5000 mV	- 1.5023 mV	_____	- 1.4977 mV	4.1E-7 V	5:1
	- 0.8000 mV	- 0.8023 mV	_____	- 0.7977 mV	4.1E-7 V	5:1
	0.0000 mV	- 0.0022 mV	_____	+0.0022 mV	4.0E-7 V	5:1
	+0.8000 mV	+0.7977 mV	_____	+0.8023 mV	4.1E-7 V	5:1
	+1.5000 mV	+1.4977 mV	_____	+1.5023 mV	4.1E-7 V	5:1
	+2.5000 mV	+2.4976 mV	_____	+2.5024 mV	4.2E-7 V	6:1
	+3.0000 mV	+2.9975 mV	_____	+3.0025 mV	4.2E-7 V	6:1
	1.0V	- 12.8000 mV	- 12.8036 mV	_____	- 12.7964 mV	4.9E-7 V
- 9.6000 mV		- 9.6033 mV	_____	- 9.5967 mV	4.7E-7 V	7:1
- 6.4000 mV		- 6.4029 mV	_____	- 6.3971 mV	4.4E-7 V	6:1
- 3.2000 mV		- 3.2026 mV	_____	- 3.1974 mV	4.2E-7 V	6:1
0.0000 mV		- 0.0023 mV	_____	+ 0.0021 mV	4.0E-7 V	6:1
+ 3.2000 mV		+ 3.1974 mV	_____	+ 3.2024 mV	4.2E-7 V	6:1
+ 6.4000 mV		+ 6.3971 mV	_____	+ 6.4027 mV	4.4E-7 V	6:1
+ 9.6000 mV		+ 9.5967 mV	_____	+ 9.6031 mV	4.7E-7 V	7:1
+12.8000 mV		+12.7964 mV	_____	+12.8034 mV	4.9E-7 V	7:1
4.0V		- 50.0000 mV	- 50.0083 mV	_____	- 49.9918 mV	7.5E-7 V
	- 37.5000 mV	- 37.5070 mV	_____	- 37.4930 mV	6.6E-7 V	10:1
	- 25.0000 mV	- 25.0057 mV	_____	- 24.9943 mV	5.8E-7 V	9:1
	- 12.5000 mV	- 12.5045 mV	_____	- 12.4955 mV	4.9E-7 V	9:1
	0.0000 mV	- 0.0033 mV	_____	+ 0.0033 mV	4.0E-7 V	7:1
	+12.5000 mV	+12.4955 mV	_____	+12.5045 mV	4.9E-7 V	9:1
	+25.0000 mV	+24.9943 mV	_____	+25.0057 mV	5.8E-7 V	9:1
	+37.5000 mV	+37.4930 mV	_____	+37.5070 mV	6.6E-7 V	10:1
	+50.0000 mV	+49.9918 mV	_____	+50.0083 mV	7.5E-7 V	>10:1
	16.0V	- 200.0000 mV	- 200.029 mV	_____	- 199.971 mV	1.2E-6 V
- 150.0000 mV		- 150.024 mV	_____	- 149.976 mV	1.0E-6 V	>10:1
- 100.0000 mV		- 100.019 mV	_____	- 99.986 mV	8.0E-7 V	>10:1
- 50.0000 mV		- 50.014 mV	_____	- 49.987 mV	6.0E-7 V	>10:1
0.0000 mV		- 0.009 mV	_____	+ 0.009 mV	4.0E-7 V	10:1
+ 50.0000 mV		+ 49.986 mV	_____	+ 50.014 mV	6.0E-7 V	>10:1
+100.0000 mV		+ 99.981 mV	_____	+100.019 mV	8.0E-7 V	>10:1
+150.0000 mV		+149.976 mV	_____	+150.024 mV	1.0E-6 V	>10:1
+200.0000 mV		+199.971 mV	_____	+200.029 mV	1.2E-6 V	>10:1

Table 2-1. Performance Test Record for the HP E1415A and HP E1419A (Page 16 of 37)

Test 2-5: DCV Measurement Accuracy - E1503A Amplifier+Filter SCP (Gain X64 and Filter OFF)						
Ctrl Range	Input	Minimum	Measured	Maximum	M.U.	TAR
.25 V	- 3.0000 mV	- 3.0025 mV	_____	- 2.9975 mV	4.2E-7 V	6:1
	- 2.5000 mV	- 2.5024 mV	_____	- 2.4976 mV	4.2E-7 V	6:1
	- 1.5000 mV	- 1.5023 mV	_____	- 1.4977 mV	4.1E-7 V	5:1
	- 0.8000 mV	- 0.8023 mV	_____	- 0.7977 mV	4.1E-7 V	5:1
	0.0000 mV	- 0.0022 mV	_____	+0.0022 mV	4.0E-7 V	5:1
	+0.8000 mV	+0.7977 mV	_____	+0.8023 mV	4.1E-7 V	5:1
	+1.5000 mV	+1.4977 mV	_____	+1.5023 mV	4.1E-7 V	5:1
	+2.5000 mV	+2.4976 mV	_____	+2.5024 mV	4.2E-7 V	6:1
	+3.0000 mV	+2.9975 mV	_____	+3.0025 mV	4.2E-7 V	6:1
	1.0V	- 12.8000 mV	- 12.8036 mV	_____	- 12.7964 mV	4.9E-7 V
- 9.6000 mV		- 9.6033 mV	_____	- 9.5967 mV	4.7E-7 V	7:1
- 6.4000 mV		- 6.4029 mV	_____	- 6.3971 mV	4.4E-7 V	6:1
- 3.2000 mV		- 3.2026 mV	_____	- 3.1974 mV	4.2E-7 V	6:1
0.0000 mV		- 0.0023 mV	_____	+ 0.0023 mV	4.0E-7 V	6:1
+ 3.2000 mV		+ 3.1974 mV	_____	+ 3.2026 mV	4.2E-7 V	6:1
+ 6.4000 mV		+ 6.3971 mV	_____	+ 6.4029 mV	4.4E-7 V	6:1
+ 9.6000 mV		+ 9.5967 mV	_____	+ 9.6033 mV	4.7E-7 V	7:1
+12.8000 mV		+12.7964 mV	_____	+12.8036 mV	4.9E-7 V	7:1
4.0V		- 50.0000 mV	- 50.0083 mV	_____	- 49.9918 mV	7.5E-7 V
	- 37.5000 mV	- 37.5070 mV	_____	- 37.4930 mV	6.6E-7 V	10:1
	- 25.0000 mV	- 25.0057 mV	_____	- 24.9943 mV	5.8E-7 V	9:1
	- 12.5000 mV	- 12.5045 mV	_____	- 12.4955 mV	4.9E-7 V	9:1
	0.0000 mV	- 0.0033 mV	_____	+ 0.0033 mV	4.0E-7 V	7:1
	+12.5000 mV	+12.4955 mV	_____	+12.5045 mV	4.9E-7 V	9:1
	+25.0000 mV	+24.9943 mV	_____	+25.0057 mV	5.8E-7 V	9:1
	+37.5000 mV	+37.4930 mV	_____	+37.5070 mV	6.6E-7 V	10:1
	+50.0000 mV	+49.9918 mV	_____	+50.0083 mV	7.5E-7 V	>10:1
	16.0V	- 200.0000 mV	- 200.029 mV	_____	- 199.971 mV	1.2E-6 V
- 150.0000 mV		- 150.024 mV	_____	- 149.976 mV	1.0E-6 V	>10:1
- 100.0000 mV		- 100.019 mV	_____	- 99.981 mV	8.0E-7 V	>10:1
- 50.0000 mV		- 50.014 mV	_____	- 49.986 mV	6.0E-7 V	>10:1
0.0000 mV		- 0.009 mV	_____	+ 0.009 mV	4.0E-7 V	>10:1
+ 50.0000 mV		+ 49.986 mV	_____	+ 50.014 mV	6.0E-7 V	>10:1
+100.0000 mV		+ 99.981 mV	_____	+100.019 mV	8.0E-7 V	>10:1
+150.0000 mV		+149.976 mV	_____	+150.024 mV	1.0E-6 V	>10:1
+200.0000 mV		+199.971 mV	_____	+200.029 mV	1.2E-6 V	>10:1

Table 2-1. Performance Test Record for the HP E1415A and HP E1419A (Page 17 of 37)

Test 2-6: DCI Measurement Accuracy - E1505A Current Source SCP						
Ctrl Range	Output	Minimum	Measured	Maximum	M.U.	TAR
30 μ A	30.518 μ A	30.509 μ A	_____	30.527 μ A	1.26E-9	7:1
488 μ A	488.28 μ A	488.22 μ A	_____	488.34 μ A	1.28E-8	5:1
Test 2-7: Excitation Voltage Measurement Accuracy - E1506A 120Ω Strain Gage SCP						
Ctrl Range	Output	Minimum	Measured	Maximum	M.U.	TAR
3.9 Vdc	3.9 Vdc	3.899488 Vdc	_____	3.900512 Vdc	1.65E-5	31:1
Test 2-8: Excitation Voltage Measurement Accuracy - E1507A 350Ω Strain Gage SCP						
Ctrl Range	Output	Minimum	Measured	Maximum	M.U.	TAR
3.9 Vdc	3.9 Vdc	3.899488 Vdc	_____	3.900512 Vdc	1.65E-5	31:1

Table 2-1. Performance Test Record for the HP E1415A and HP E1419A (Page 18 of 37)

Test 2-9: DCV Measurement Accuracy - E1508A Fixed Filter + Amplifier SCP						
Ctrl Range	Input	Minimum	Measured	Maximum	M.U.	TAR
.0625V	- 3.0000 mV	- 3.0043 mV	_____	- 2.9957 mV	4.2E-7 V	10:1
	- 2.3000 mV	- 2.3042 mV	_____	- 2.2958 mV	4.2E-7 V	10:1
	- 1.5000 mV	- 1.5041 mV	_____	- 1.4959 mV	4.1E-7 V	10:1
	- 0.8000 mV	- 0.8041 mV	_____	- 0.7960 mV	4.1E-7 V	10:1
	0.0000 mV	- 0.0040 mV	_____	+0.0040 mV	4.0E-7 V	10:1
	+0.8000 mV	+0.7960 mV	_____	+0.8041 mV	4.1E-7 V	10:1
	+1.5000 mV	+1.4959 mV	_____	+1.5041 mV	4.1E-7 V	10:1
	+2.3000 mV	+2.2958 mV	_____	+2.3042 mV	4.2E-7 V	10:1
	+3.0000 mV	+2.9957 mV	_____	+3.0043 mV	4.2E-7 V	10:1
	.25V	- 13.0000 mV	- 13.0057 mV	_____	- 12.9943 mV	4.9E-7 V
- 9.0000 mV		- 9.0053 mV	_____	- 8.9947 mV	4.7E-7 V	>10:1
- 6.0000 mV		- 6.0050 mV	_____	- 5.9950 mV	4.4E-7 V	>10:1
- 3.0000 mV		- 3.0047 mV	_____	- 2.9953 mV	4.2E-7 V	>10:1
0.0000 mV		- 0.0044 mV	_____	+ 0.0044 mV	4.0E-7 V	>10:1
+ 3.0000 mV		+ 2.9953 mV	_____	+ 3.0047 mV	4.2E-7 V	>10:1
+ 6.0000 mV		+ 5.9950 mV	_____	+ 6.0050 mV	4.4E-7 V	>10:1
+ 9.0000 mV		+ 8.9947 mV	_____	+ 9.0053 mV	4.7E-7 V	>10:1
+13.0000 mV		+12.9943 mV	_____	+13.0057 mV	4.9E-7 V	>10:1
1.0V		- 50.0000 mV	- 50.0103 mV	_____	- 49.9897 mV	7.5E-7 V
	- 37.5000 mV	- 37.5090 mV	_____	- 37.4910 mV	6.6E-7 V	>10:1
	- 25.0000 mV	- 25.0078 mV	_____	- 24.9922 mV	5.8E-7 V	>10:1
	- 13.0000 mV	- 13.0066 mV	_____	- 12.9934 mV	4.9E-7 V	>10:1
	0.0000 mV	- 0.0053 mV	_____	+ 0.0053 mV	4.0E-7 V	>10:1
	+13.0000 mV	+12.9934 mV	_____	+13.0066 mV	4.9E-7 V	>10:1
	+25.0000 mV	+24.9922 mV	_____	+25.0078 mV	5.8E-7 V	>10:1
	+37.5000 mV	+37.4910 mV	_____	+37.5090 mV	6.6E-7 V	>10:1
	+50.0000 mV	+49.9897 mV	_____	+50.0103 mV	7.5E-7 V	>10:1
	4.0V	- 200.000 mV	- 200.029 mV	_____	- 199.971 mV	1.6E-6 V
- 150.000 mV		- 150.024 mV	_____	- 149.976 mV	1.4E-6 V	>10:1
- 100.000 mV		- 100.019 mV	_____	- 99.981 mV	1.2E-6 V	>10:1
- 50.000 mV		- 50.014 mV	_____	- 49.986 mV	1.0E-6 V	>10:1
0.000 mV		- 0.009 mV	_____	+ 0.009 mV	0.8E-6 V	10:1
+ 50.000 mV		+ 49.986 mV	_____	+ 50.014 mV	1.0E-6 V	>10:1
+100.000 mV		+ 99.981 mV	_____	+100.019 mV	1.2E-6 V	>10:1
+150.000 mV		+149.976 mV	_____	+150.024 mV	1.4E-6 V	>10:1
+200.000 mV		+199.971 mV	_____	+200.029 mV	1.6E-6 V	>10:1
16.0V		- 800.000 mV	- 800.117 mV	_____	- 799.883 mV	4.0E-6 V
	- 600.000 mV	- 600.097 mV	_____	- 599.903 mV	3.2E-6 V	>10:1
	- 400.000 mV	- 400.077 mV	_____	- 399.923 mV	2.4E-6 V	>10:1
	- 200.000 mV	- 200.057 mV	_____	- 199.943 mV	1.6E-6 V	>10:1
	0.000 mV	- 0.037 mV	_____	+ 0.0371 mV	0.8E-6 V	>10:1
	+200.000 mV	+199.943 mV	_____	+200.057 mV	1.6E-6 V	>10:1
	+400.000 mV	+399.923 mV	_____	+400.077 mV	2.4E-6 V	>10:1
	+600.000 mV	+599.903 mV	_____	+600.097 mV	3.2E-6 V	>10:1
	+800.000 mV	+799.883 mV	_____	+800.117 mV	4.0E-6 V	>10:1

Table 2-1. Performance Test Record for the HP E1415A and HP E1419A (Page 19 of 37)

Test 2-10: DCV Measurement Accuracy - E1509A Fixed Filter + Amplifier SCP						
Ctrl Range	Input	Minimum	Measured	Maximum	M.U.	TAR
.25V	- 3.0000 mV	- 3.0027 mV	_____	- 2.9973 mV	4.2E-7 V	6:1
	- 2.3000 mV	- 2.3027 mV	_____	- 2.2974 mV	4.2E-7 V	6:1
	- 1.5000 mV	- 1.5025 mV	_____	- 1.4975 mV	4.1E-7 V	6:1
	- 0.8000 mV	- 0.8025 mV	_____	- 0.7975 mV	4.1E-7 V	6:1
	0.0000 mV	- 0.0024 mV	_____	+0.0024 mV	4.0E-7 V	6:1
	+0.8000 mV	+0.7975 mV	_____	+0.8025 mV	4.1E-7 V	6:1
	+1.5000 mV	+1.4975 mV	_____	+1.5025 mV	4.1E-7 V	6:1
	+2.3000 mV	+2.2974 mV	_____	+2.3026 mV	4.2E-7 V	6:1
	+3.0000 mV	+2.9973 mV	_____	+3.0027 mV	4.2E-7 V	6:1
	1.0V	- 13.0000 mV	- 13.0038 mV	_____	- 12.9962 mV	4.9E-7 V
- 9.0000 mV		- 9.0034 mV	_____	- 8.9966 mV	4.7E-7 V	7:1
- 6.0000 mV		- 6.0031 mV	_____	- 5.9969 mV	4.4E-7 V	7:1
- 3.0000 mV		- 3.0028 mV	_____	- 2.9972 mV	4.2E-7 V	6:1
0.0000 mV		- 0.0025 mV	_____	+ 0.0025 mV	4.0E-7 V	6:1
+ 3.0000 mV		+ 2.9972 mV	_____	+ 3.2028 mV	4.2E-7 V	6:1
+ 6.0000 mV		+ 5.9969 mV	_____	+ 6.0031 mV	4.4E-7 V	7:1
+ 9.0000 mV		+ 8.9966 mV	_____	+ 9.6034 mV	4.7E-7 V	7:1
+13.0000 mV		+12.9962 mV	_____	+13.3038 mV	4.9E-7 V	8:1
4.0V		- 50.0000 mV	- 50.0084 mV	_____	- 49.9917 mV	7.5E-7 V
	- 37.5000 mV	- 37.5071 mV	_____	- 37.4929 mV	6.6E-7 V	10:1
	- 25.0000 mV	- 25.0059 mV	_____	- 24.9941 mV	5.8E-7 V	10:1
	- 13.0000 mV	- 13.0047 mV	_____	- 12.9953 mV	4.9E-7 V	9:1
	0.0000 mV	- 0.0034 mV	_____	+ 0.0034 mV	4.0E-7 V	8:1
	+13.0000 mV	+12.9953 mV	_____	+13.0047 mV	4.9E-7 V	9:1
	+25.0000 mV	+24.9941 mV	_____	+25.0059 mV	5.8E-7 V	10:1
	+37.5000 mV	+37.4929 mV	_____	+37.5071 mV	6.6E-7 V	10:1
	+50.0000 mV	+49.9917 mV	_____	+50.0084 mV	7.5E-7 V	>10:1
	16V	- 200.0000 mV	- 200.029 mV	_____	- 199.971 mV	1.2E-6 V
- 150.0000 mV		- 150.024 mV	_____	- 149.976 mV	1.0E-6 V	>10:1
- 100.0000 mV		- 100.019 mV	_____	- 99.981 mV	8.0E-7 V	>10:1
- 50.0000 mV		- 50.014 mV	_____	- 49.986 mV	6.0E-7 V	>10:1
0.0000 mV		- 0.009 mV	_____	+ 0.009 mV	4.0E-7 V	10:1
+ 50.0000 mV		+ 49.986 mV	_____	+ 50.014 mV	6.0E-7 V	>10:1
+100.0000 mV		+ 99.981 mV	_____	+100.019 mV	8.0E-7 V	>10:1
+150.0000 mV		+149.976 mV	_____	+150.024 mV	1.0E-6 V	>10:1
+200.0000 mV		+199.971 mV	_____	+200.029 mV	1.2E-6 V	>10:1

Table 2-1. Performance Test Record for the HP E1415A and HP E1419A (Page 20 of 37)

Test 2-11: DCV Measurement Accuracy, Sample, & Hold Channels - E1510A Sample & Hold SCP						
Gain / Ctlr Range	Input	Minimum	Measured	Maximum	M.U.	TAR
Gain X0.5: 0.0625VDC	- 0.1 VDC	-0.100583 VDC	_____	-0.099417 VDC	1.20E-6 V	>10:1
	0.0 VDC	-0.000563 VDC	_____	+0.000563 VDC	0.80E-6 V	>10:1
	+0.1 VDC	+0.099417 VDC	_____	+0.100583 VDC	1.20E-6 V	>10:1
0.25 VDC	- 0.4 VDC	-0.400643 VDC	_____	-0.399357 VDC	2.40E-6 V	>10:1
	0.0 VDC	-0.000563 VDC	_____	+0.000563 VDC	0.80E-6 V	>10:1
	+0.4 VDC	+0.399357 VDC	_____	+0.400643 VDC	2.40E-6 V	>10:1
1.0 VDC	- 1.6 VDC	-1.600883 VDC	_____	-1.599117 VDC	7.00E-6 V	>10:1
	0.0 VDC	-0.000563 VDC	_____	+0.000563 VDC	0.80E-6 V	>10:1
	+1.6 VDC	+1.599117 VDC	_____	+1.600883 VDC	7.00E-6 V	>10:1
4.0 VDC	- 6.4 VDC	-6.401843 VDC	_____	-6.398157 VDC	19.0E-6 V	>10:1
	0.0 VDC	-0.000563 VDC	_____	+0.000563 VDC	0.80E-6 V	>10:1
	+6.4 VDC	+6.398157 VDC	_____	+6.401843 VDC	19.0E-6 V	>10:1
Gain X8: 0.0625 VDC	- 0.00624	-0.006276 VDC	_____	-0.006204 VDC	0.44E-6 V	>10:1
	0.0	-0.000035 VDC	_____	+0.000035 VDC	0.40E-6 V	>10:1
	+0.00624	+0.006204 VDC	_____	+0.006276 VDC	0.44E-6 V	>10:1
0.25 VDC	- 0.025	-0.025040 VDC	_____	-0.024960 VDC	0.57E-6 V	>10:1
	0.0	-0.000035 VDC	_____	+0.000035 VDC	0.40E-6 V	>10:1
	+0.025	+0.024960 VDC	_____	+0.025040 VDC	0.57E-6 V	>10:1
1.0 VDC	- 0.1	-0.100055 VDC	_____	-0.099945 VDC	1.20E-6 V	>10:1
	0.0	-0.000035 VDC	_____	+0.000035 VDC	0.80E-6 V	>10:1
	+0.1	+0.099945 VDC	_____	+0.100055 VDC	1.20E-6 V	>10:1
4.0 VDC	- 0.4	-0.400115 VDC	_____	-0.399885 VDC	2.40E-6 V	>10:1
	0.0	-0.000035 VDC	_____	+0.000035 VDC	0.80E-6 V	>10:1
	+0.4	+0.399885 VDC	_____	+0.400115 VDC	2.40E-6 V	>10:1
Gain X64: 0.25 VDC	- 0.00312	-0.003136 VDC	_____	-0.003104 VDC	0.42E-6 V	>10:1
	0.0	-0.000016 VDC	_____	+0.000016 VDC	0.40E-6 V	>10:1
	+0.00312	+0.003104 VDC	_____	+0.003136 VDC	0.42E-6 V	>10:1
1.0 VDC	- 0.0125	-0.012518 VDC	_____	-0.012482 VDC	0.49E-6 V	>10:1
	0.0	-0.000016 VDC	_____	+0.000016 VDC	0.40E-6 V	>10:1
	+0.0125	+0.012482 VDC	_____	+0.012518 VDC	0.49E-6 V	>10:1
4.0 VDC	- 0.05	-0.050026 VDC	_____	-0.049974 VDC	0.75E-6 V	>10:1
	0.0	-0.000016 VDC	_____	+0.000016 VDC	0.40E-6 V	>10:1
	+0.05	+0.049974 VDC	_____	+0.050026 VDC	0.75E-6 V	>10:1
Gain X512: 4.0VDC	- 0.00625	-0.006268 VDC	_____	-0.006232 VDC	0.44E-6 V	>10:1
	0.0	-0.000018 VDC	_____	+0.000018 VDC	0.40E-6 V	>10:1
	+0.00625	+0.006232 VDC	_____	+0.006268 VDC	0.44E-6 V	>10:1

Table 2-1. Performance Test Record for the HP E1415A and HP E1419A (Page 20 of 37)

Test 2-11: DCV Measurement Accuracy, Sample, & Hold Channels - E1510A Sample & Hold SCP						
Sample & Hold Droop	4 V Range, X0.5 Gain, 7.5 VDC Input	----	_____	1 V/S	----	----

Table 2-1. Performance Test Record for the HP E1415A and HP E1419A (Page 21 of 37)

Test 2-13: DCV Measurement Accuracy, Straight-Through Channels - E1510A Sample & Hold SCP						
Ctlr Range	Input	Minimum	Measured	Maximum	M.U.*	TAR**
.0625 V	- 50.0000 mV	- 50.0112 mV	_____	- 49.9888 mV	7.5E-7 V	>10:1
	- 37.0000 mV	- 37.0099 mV	_____	- 36.9901 mV	6.6E-7 V	>10:1
	- 25.0000 mV	- 25.0087 mV	_____	- 24.9913 mV	5.8E-7 V	>10:1
	- 12.0000 mV	- 12.0074 mV	_____	- 11.9926 mV	4.8E-7 V	>10:1
	0.0000 mV	- 0.0062 mV	_____	+ 0.0062 mV	4.0E-7 V	>10:1
	+ 12.0000 mV	+ 11.9926 mV	_____	+ 12.0074 mV	4.8E-7 V	>10:1
	+ 25.0000 mV	+ 24.9913 mV	_____	+ 25.0087 mV	5.8E-7 V	>10:1
	+ 37.0000 mV	+ 36.9901 mV	_____	+ 37.0099 mV	6.6E-7 V	>10:1
	+ 50.0000 mV	+ 49.9888 mV	_____	+ 50.0112 mV	7.5E-7 V	>10:1
	.25 V	- 200.0000 mV	- 200.0325 mV	_____	- 199.9675 mV	1.6E-6 V
- 150.0000 mV		- 150.0275 mV	_____	- 149.9725 mV	1.4E-6 V	>10:1
- 100.0000 mV		- 100.0226 mV	_____	- 99.9775 mV	1.2E-6 V	>10:1
- 50.0000 mV		- 50.0176 mV	_____	- 49.9825 mV	1.0E-6 V	>10:1
0.0000 mV		- 0.0126 mV	_____	+ 0.0126 mV	8.0E-7 V	>10:1
+ 50.0000 mV		+ 49.9825 mV	_____	+ 50.0176 mV	1.0E-6 V	>10:1
+100.0000 mV		+ 99.9775 mV	_____	+100.0226 mV	1.2E-6 V	>10:1
+150.0000 mV		+149.9725 mV	_____	+150.0275 mV	1.4E-6 V	>10:1
+200.0000 mV		+199.9675 mV	_____	+200.0325 mV	1.6E-6 V	>10:1
1.0V		- 800.000 mV	- 800.117 mV	_____	- 799.884 mV	4.0E-6 V
	- 600.000 mV	- 600.097 mV	_____	- 599.904 mV	3.2E-6 V	>10:1
	- 400.000 mV	- 400.077 mV	_____	- 399.924 mV	2.4E-6 V	>10:1
	- 200.000 mV	- 200.057 mV	_____	- 199.944 mV	1.6E-6 V	>10:1
	0.000 mV	- 0.037 mV	_____	+ 0.037 mV	0.8E-6 V	>10:1
	+200.000 mV	+199.944 mV	_____	+200.057 mV	1.6E-6 V	>10:1
	+400.000 mV	+399.924 mV	_____	+400.077 mV	2.4E-6 V	>10:1
	+600.000 mV	+599.904 mV	_____	+600.097 mV	3.2E-6 V	>10:1
	+800.000 mV	+799.884 mV	_____	+800.117 mV	4.0E-6 V	>10:1
	4.0V	- 3.2000 V	- 3.2005 V	_____	- 3.1995 V	1.1E-5 V
- 2.4000 V		- 2.4004 V	_____	- 2.3996 V	9.0E-6 V	>10:1
- 1.6000 V		- 1.6003 V	_____	- 1.5997 V	7.0E-6 V	>10:1
- 0.8000 V		- 0.8002 V	_____	- 0.7998 V	5.0E-6 V	>10:1
0.0000 V		- 0.0001 V	_____	+0.0001 V	3.0E-6 V	>10:1
+0.8000 V		+0.7998 V	_____	+0.8002 V	5.0E-6 V	>10:1
+1.6000 V		+1.5997 V	_____	+1.6003 V	7.0E-6 V	>10:1
+2.4000 V		+2.3996 V	_____	+2.4004 V	9.0E-6 V	>10:1
+3.2000 V		+3.1995 V	_____	+3.2005 V	1.1E-5 V	>10:1

Table 2-1. Performance Test Record for the HP E1415A and HP E1419A (Page 21 of 37)

Test 2-13: DCV Measurement Accuracy, Straight-Through Channels - E1510A Sample & Hold SCP						
16.0V	- 12.8000 V	- 12.8019 V	_____	- 12.7981 V	1.0E-4 V	>10:1
	- 9.6000 V	- 9.6015 V	_____	- 9.5985 V	8.8E-5 V	>10:1
	- 6.4000 V	- 6.4012 V	_____	- 6.3988 V	7.6E-5 V	>10:1
	- 3.2000 V	- 3.2009 V	_____	- 3.1991 V	6.3E-5 V	>10:1
	0.0000 V	- 0.0006 V	_____	+ 0.0006 V	5.0E-5 V	10:1
	+ 3.2000 V	+ 3.1991 V	_____	+ 3.2009 V	6.3E-5 V	>10:1
	+ 6.4000 V	+ 6.3988 V	_____	+ 6.4012 V	7.6E-5 V	>10:1
	+ 9.6000 V	+ 9.5985 V	_____	+ 9.6015 V	8.8E-5 V	>10:1
	+12.8000 V	+12.7981 V	_____	+12.8019 V	1.0E-4 V	>10:1

Table 2-1. Performance Test Record for the HP E1415A and HP E1419A (Page 22 of 37)

Test 2-12: DCV Measurement Accuracy, Bridge Sense Channels - E1511A Transient Strain SCP						
Gain / Ctlr Range	Input	Minimum	Measured	Maximum	M.U.	TAR
Gain X0.5: 0.0625VDC	- 0.1 VDC	-0.100583 VDC	_____	-0.099417 VDC	1.20E-6 V	>10:1
	0.0 VDC	-0.000563 VDC	_____	+0.000563 VDC	0.80E-6 V	>10:1
	+0.1 VDC	+0.099417 VDC	_____	+0.100583 VDC	1.20E-6 V	>10:1
0.25 VDC	- 0.4 VDC	-0.400643 VDC	_____	-0.399357 VDC	2.40E-6 V	>10:1
	0.0 VDC	-0.000563 VDC	_____	+0.000563 VDC	0.80E-6 V	>10:1
	+0.4 VDC	+0.399357 VDC	_____	+0.400643 VDC	2.40E-6 V	>10:1
1.0 VDC	- 1.6 VDC	-1.600883 VDC	_____	-1.599117 VDC	7.00E-6 V	>10:1
	0.0 VDC	-0.000563 VDC	_____	+0.000563 VDC	0.80E-6 V	>10:1
	+1.6 VDC	+1.599117 VDC	_____	+1.600883 VDC	7.00E-6 V	>10:1
4.0 VDC	- 6.4 VDC	-6.401843 VDC	_____	-6.398157 VDC	19.0E-6 V	>10:1
	0.0 VDC	-0.000563 VDC	_____	+0.000563 VDC	0.80E-6 V	>10:1
	+6.4 VDC	+6.398157 VDC	_____	+6.401843 VDC	19.0E-6 V	>10:1
Gain X8: 0.0625 VDC	- 0.00624	-0.006276 VDC	_____	-0.006204 VDC	0.44E-6 V	>10:1
	0.0	-0.000035 VDC	_____	+0.000035 VDC	0.40E-6 V	>10:1
	+0.00624	+0.006204 VDC	_____	+0.006276 VDC	0.44E-6 V	>10:1
0.25 VDC	- 0.025	-0.025040 VDC	_____	-0.024960 VDC	0.57E-6 V	>10:1
	0.0	-0.000035 VDC	_____	+0.000035 VDC	0.40E-6 V	>10:1
	+0.025	+0.024960 VDC	_____	+0.025040 VDC	0.57E-6 V	>10:1
1.0 VDC	- 0.1	-0.100055 VDC	_____	-0.099945 VDC	1.20E-6 V	>10:1
	0.0	-0.000035 VDC	_____	+0.000035 VDC	0.80E-6 V	>10:1
	+0.1	+0.099945 VDC	_____	+0.100055 VDC	1.20E-6 V	>10:1
4.0 VDC	- 0.4	-0.400115 VDC	_____	-0.399885 VDC	2.40E-6 V	>10:1
	0.0	-0.000035 VDC	_____	+0.000035 VDC	0.80E-6 V	>10:1
	+0.4	+0.399885 VDC	_____	+0.400115 VDC	2.40E-6 V	>10:1
Gain X64: 0.25 VDC	- 0.00312	-0.003136 VDC	_____	-0.003104 VDC	0.42E-6 V	>10:1
	0.0	-0.000016 VDC	_____	+0.000016 VDC	0.40E-6 V	>10:1
	+0.00312	+0.003104 VDC	_____	+0.003136 VDC	0.42E-6 V	>10:1

Table 2-1. Performance Test Record for the HP E1415A and HP E1419A (Page 22 of 37)

Test 2-12: DCV Measurement Accuracy, Bridge Sense Channels - E1511A Transient Strain SCP						
1.0 VDC	- 0.0125 0.0 +0.0125	-0.012518 VDC -0.000016 VDC +0.012482 VDC	_____	-0.012482 VDC +0.000016 VDC +0.012518 VDC	0.49E-6 V 0.40E-6 V 0.49E-6 V	>10:1 >10:1 >10:1
4.0 VDC	- 0.05 0.0 +0.05	-0.050026 VDC -0.000016 VDC +0.049974 VDC	_____	-0.049976 VDC +0.000016 VDC +0.050024 VDC	0.75E-6 V 0.40E-6 V 0.75E-6 V	>10:1 >10:1 >10:1
Gain X512: 4.0VDC	- 0.00625 0.0 +0.00625	-0.006268 VDC -0.000018 VDC +0.006232 VDC	_____	-0.006232 VDC +0.000018 VDC +0.006268 VDC	0.44E-6 V 0.40E-6 V 0.44E-6 V	>10:1 >10:1 >10:1
Sample & Hold Droop	4 V Range, X0.5 Gain, 7.5 VDC Input	----	_____	1 V/S	----	----

Table 2-1. Performance Test Record for the HP E1415A and HP E1419A (Page 23 of 37)

Test 2-14: Excitation Voltage Measurement - E1511A Transient Strain SCP						
Ctrl Range	Output	Minimum	Measured	Maximum	M.U.	TAR
1 VDC	1 VDC	---	_____	---	1.65E-5	31:1
2 VDC	2 VDC	---	_____	---	1.65E-5	31:1
5 VDC	5 VDC	---	_____	---	1.65E-5	31:1
10 VDC	10 VDC	---	_____	---	1.65E-5	31:1

Table 2-1. Performance Test Record for the HP E1415A and HP E1419A (Page 24 of 37)

Test 2-15: DCV Measurement Accuracy - E1512A 25 Hz Low Pass Filter						
Ctrl Range	Input	Minimum	Measured	Maximum	M.U.*	TAR**
.0625 V	- 50.0000 mV	- 50.0129 mV	_____	- 49.9871 mV	7.5E-7 V	>10:1
	- 37.0000 mV	- 37.0116 mV	_____	- 36.9883 mV	6.6E-7 V	>10:1
	- 25.0000 mV	- 25.0104 mV	_____	- 24.9996 mV	5.8E-7 V	>10:1
	- 12.0000 mV	- 12.0092 mV	_____	- 11.9909 mV	4.8E-7 V	>10:1
	0.0000 mV	- 0.0080 mV	_____	+ 0.0080 mV	4.0E-7 V	>10:1
	+ 12.0000 mV	+ 11.9909 mV	_____	+ 12.0092 mV	4.8E-7 V	>10:1
	+ 25.0000 mV	+ 24.9896 mV	_____	+ 25.0104 mV	5.8E-7 V	>10:1
	+ 37.0000 mV	+ 36.9883 mV	_____	+ 37.0116 mV	6.6E-7 V	>10:1
	+ 50.0000 mV	+ 49.9871 mV	_____	+ 50.0129 mV	7.5E-7 V	>10:1
	.25 V	- 200.0000 mV	- 200.0336 mV	_____	- 199.9664 mV	1.6E-6 V
- 150.0000 mV		- 150.0286 mV	_____	- 149.9714 mV	1.4E-6 V	>10:1
- 100.0000 mV		- 100.0236 mV	_____	- 99.9764 mV	1.2E-6 V	>10:1
- 50.0000 mV		- 50.0186 mV	_____	- 49.9814 mV	1.0E-6 V	>10:1
0.0000 mV		- 0.0136 mV	_____	+ 0.0136 mV	8.0E-7 V	>10:1
+ 50.0000 mV		+ 49.9814 mV	_____	+ 50.0186 mV	1.0E-6 V	>10:1
+100.0000 mV		+ 99.9764 mV	_____	+100.0236 mV	1.2E-6 V	>10:1
+150.0000 mV		+149.9714 mV	_____	+150.0286 mV	1.4E-6 V	>10:1
+200.0000 mV		+199.9664 mV	_____	+200.0336 mV	1.6E-6 V	>10:1
1.0V		- 800.000 mV	- 800.118 mV	_____	- 799.884 mV	4.0E-6 V
	- 600.000 mV	- 600.098 mV	_____	- 599.904 mV	3.2E-6 V	>10:1
	- 400.000 mV	- 400.078 mV	_____	- 399.924 mV	2.4E-6 V	>10:1
	- 200.000 mV	- 200.058 mV	_____	- 199.944 mV	1.6E-6 V	>10:1
	0.000 mV	- .038 mV	_____	+ .038 mV	0.8E-6 V	>10:1
	+200.000 mV	+199.944 mV	_____	+200.058 mV	1.6E-6 V	>10:1
	+400.000 mV	+399.924 mV	_____	+400.078 mV	2.4E-6 V	>10:1
	+600.000 mV	+599.904 mV	_____	+600.098 mV	3.2E-6 V	>10:1
	+800.000 mV	+799.884 mV	_____	+800.118 mV	4.0E-6 V	>10:1
	4.0V	- 3.2000 V	- 3.2005 V	_____	- 3.1995 V	1.1E-5 V
- 2.4000 V		- 2.4004 V	_____	- 2.3996 V	9.0E-6 V	>10:1
- 1.6000 V		- 1.6003 V	_____	- 1.5997 V	7.0E-6 V	>10:1
- 0.8000 V		- 0.8002 V	_____	- 0.7998 V	5.0E-6 V	>10:1
0.0000 V		- 0.0001 V	_____	+0.0001 V	3.0E-6 V	>10:1
+0.8000 V		+0.7998 V	_____	+0.8002 V	5.0E-6 V	>10:1
+1.6000 V		+1.5997 V	_____	+1.6003 V	7.0E-6 V	>10:1
+2.4000 V		+2.3996 V	_____	+2.4004 V	9.0E-6 V	>10:1
+3.2000 V		+3.1995 V	_____	+3.2005 V	1.1E-5 V	>10:1
16.0V		- 12.8000 V	- 12.8018 V	_____	- 12.7982 V	1.0E-4 V
	- 9.6000 V	- 9.6015 V	_____	- 9.5985 V	8.8E-5 V	>10:1
	- 6.4000 V	- 6.4012 V	_____	- 6.3988 V	7.6E-5 V	>10:1
	- 3.2000 V	- 3.2009 V	_____	- 3.1991 V	6.3E-5 V	>10:1
	0.0000 V	- 0.0006 V	_____	+ 0.0006 V	5.0E-5 V	10:1
	+ 3.2000 V	+ 3.1991 V	_____	+ 3.2009 V	6.3E-5 V	>10:1
	+ 6.4000 V	+ 6.3988 V	_____	+ 6.4012 V	7.6E-5 V	>10:1
	+ 9.6000 V	+ 9.5985 V	_____	+ 9.6015 V	8.8E-5 V	>10:1
	+12.8000 V	+12.7982 V	_____	+12.8018 V	1.0E-4 V	>10:1

Table 2-1. Performance Test Record for the HP E1415A and HP E1419A (Page 25 of 37)

Test 2-16: DCV Measurement Accuracy - E1513A Divide by 16 Attenuator SCP						
Ctrl Range	Input	Minimum	Measured	Maximum	M.U.	TAR
1 V	-12.8000 V	-12.8032 V	_____	-12.7969 V	56E-6 V	>10:1
	- 9.6000 V	- 9.6025 V	_____	- 9.5975 V	43E-6 V	>10:1
	- 6.4000 V	- 6.4019 V	_____	- 6.3981 V	31E-6 V	>10:1
	- 3.2000 V	- 3.2012 V	_____	- 3.1988 V	18E-6 V	>10:1
	0.0000 V	- 0.0006 V	_____	+ 0.0006 V	5.0E-6 V	>10:1
	+ 3.2000 V	+ 3.1988 V	_____	+ 3.2012 V	18E-6 V	>10:1
	+ 6.4000 V	+ 6.3981 V	_____	+ 6.4019 V	31E-6 V	>10:1
	+ 9.6000 V	+ 9.5975 V	_____	+ 9.6025 V	43E-6 V	>10:1
	+12.8000 V	+12.7969 V	_____	+12.8032 V	56E-6 V	>10:1
	4 V	-51.2000 V	- 51.2125 V	_____	- 51.1875 V	210E-6 V
-38.4000 V		- 38.4100 V	_____	- 38.3900 V	159E-6 V	>10:1
-25.6000 V		- 25.6074 V	_____	- 25.5926 V	107E-6 V	>10:1
-12.8000 V		- 12.8049 V	_____	- 12.7951 V	56E-6 V	>10:1
0.0000 V		- 0.0023 V	_____	+ 0.0023 V	5.0E-6 V	>10:1
+12.8000 V		+12.7951 V	_____	+12.8049 V	56E-6 V	>10:1
+25.6000 V		+25.5926 V	_____	+25.6074 V	107E-6 V	>10:1
+38.4000 V		+38.3900 V	_____	+38.4100 V	159E-6 V	>10:1
+51.2000 V		+51.1875 V	_____	+51.2125 V	210E-6 V	>10:1

Table 2-1. Performance Test Record for the HP E1415A and HP E1419A (Page 26 of 37)

Test 2-17: DCV Measurement Accuracy - E1514A Fixed Filter and Amplifier SCP (Gain X1, 10 Hz Filter)						
Ctrl Range	Input	Minimum	Measured	Maximum	M.U.	TAR
16 V	-12.8000 V	-12.8036 V	_____	-12.7964 V	1.0E-04 V	>10:1
	- 9.6000 V	- 9.6030 V	_____	- 9.5970 V	8.8E-05 V	>10:1
	- 6.4000 V	- 6.4024 V	_____	- 6.3976 V	7.6E-05 V	>10:1
	- 3.2000 V	- 3.2017 V	_____	- 3.1983 V	6.3E-05 V	>10:1
	0.0000 V	- 0.0011 V	_____	0.0011 V	5.0E-05 V	>10:1
	+ 3.2000 V	+ 3.1983 V	_____	+ 3.2017 V	6.3E-05 V	>10:1
	+ 6.4000 V	+ 6.3976 V	_____	+ 6.4024 V	7.6E-05 V	>10:1
	+ 9.6000 V	+ 9.5970 V	_____	+ 9.6030 V	8.8E-05 V	>10:1
	+12.8000 V	+12.7964 V	_____	+12.8036 V	1.0E-04 V	>10:1

Test 2-17: DCV Measurement Accuracy - E1515A Fixed Filter and Amplifier SCP (Gain X1, 100Hz Filter)						
Ctrl Range	Input	Minimum	Measured	Maximum	M.U.	TAR
16 V	-12.8000 V	-12.8036 V	_____	-12.7964 V	1.0E-04 V	>10:1
	- 9.6000 V	- 9.6030 V	_____	- 9.5970 V	8.8E-05 V	>10:1
	- 6.4000 V	- 6.4024 V	_____	- 6.3976 V	7.6E-05 V	>10:1
	- 3.2000 V	- 3.2017 V	_____	- 3.1983 V	6.3E-05 V	>10:1
	0.0000 V	- 0.0011 V	_____	0.0011 V	5.0E-05 V	>10:1
	+ 3.2000 V	+ 3.1983 V	_____	+ 3.2017 V	6.3E-05 V	>10:1
	+ 6.4000 V	+ 6.3976 V	_____	+ 6.4024 V	7.6E-05 V	>10:1
	+ 9.6000 V	+ 9.5970 V	_____	+ 9.6030 V	8.8E-05 V	>10:1
	+12.8000 V	+12.7964 V	_____	+12.8036 V	1.0E-04 V	>10:1

Table 2-1. Performance Test Record for the HP E1415A and HP E1419A (Page 27 of 37)

Test 2-18: DCV Measurement Accuracy - E1516A Iso. Filter and Amplifier SCP (Gain X64, 10 Hz Filter)						
Ctrl Range	Input	Minimum	Measured	Maximum	M.U.	TAR
4.0 V	-0.0500 V	-0.050014 V	_____	-0.049986 V	0.75E-6	>10:1
	-0.0370 V	-0.037012 V	_____	-0.036988 V	0.66E-6	>10:1
	-0.0250 V	-0.025009 V	_____	-0.024991 V	0.57E-6	>10:1
	-0.0120 V	-0.012007 V	_____	-0.011993 V	0.48E-6	>10:1
	0.0000 V	-0.000004 V	_____	+0.000004 V	0.40E-6	10:1
	+0.0120 V	+0.011993 V	_____	+0.012007 V	0.48E-6	>10:1
	+0.0250 V	+0.024991 V	_____	+0.025009 V	0.57E-6	>10:1
	+0.0370 V	+0.036988 V	_____	+0.037012 V	0.66E-6	>10:1
	+0.0500 V	+0.049986 V	_____	+0.050014 V	0.75E-6	>10:1

Test 2-18: DCV Measurement Accuracy - E1517A Iso. Filter and Amplifier SCP (Gain X64, 100Hz Filter)						
Ctrl Range	Input	Minimum	Measured	Maximum	M.U.	TAR
4.0 V	-0.0500 V	-0.050014 V	_____	-0.049986 V	0.75E-6	>10:1
	-0.0370 V	-0.037012 V	_____	-0.036988 V	0.66E-6	>10:1
	-0.0250 V	-0.025009 V	_____	-0.024991 V	0.57E-6	>10:1
	-0.0120 V	-0.012007 V	_____	-0.011993 V	0.48E-6	>10:1
	0.0000 V	-0.000004 V	_____	+0.000004 V	0.40E-6	10:1
	+0.0120 V	+0.011993 V	_____	+0.012007 V	0.48E-6	>10:1
	+0.0250 V	+0.024991 V	_____	+0.025009 V	0.57E-6	>10:1
	+0.0370 V	+0.036988 V	_____	+0.037012 V	0.66E-6	>10:1
	+0.0500 V	+0.049986 V	_____	+0.050014 V	0.75E-6	>10:1

Table 2-1. Performance Test Record for the HP E1415A and HP E1419A (Page 28 of 37)

Test 2-19: DCI Measurement Accuracy - E1518A Resistance Measurement SCP						
Ctrl Range	Output	Minimum	Measured	Maximum	M.U.	TAR
30 μ A	30.518 μ A	30.500 μ A	_____	30.536 μ A	1.26E-9	7:1
488 μ A	488.28 μ A	488.210 μ A	_____	488.360 μ A	1.28E-8	5:1

Table 2-1. Performance Test Record for the HP E1415A and HP E1419A (Page 29 of 37)

Test 2-20: DCV Measurement Accuracy - E1518A Resistance Measurement SCP						
Ctrl Range	Input	Minimum	Measured	Maximum	M.U.	TAR
.0625V	- 3.0000 mV	- 3.0043 mV	_____	- 2.9957 mV	4.2E-7 V	10:1
	- 2.3000 mV	- 2.3042 mV	_____	- 2.2958 mV	4.2E-7 V	10:1
	- 1.5000 mV	- 1.5041 mV	_____	- 1.4959 mV	4.1E-7 V	10:1
	- 0.8000 mV	- 0.8041 mV	_____	- 0.7960 mV	4.1E-7 V	10:1
	0.0000 mV	- 0.0040 mV	_____	+0.0040 mV	4.0E-7 V	10:1
	+0.8000 mV	+0.7960 mV	_____	+0.8041 mV	4.1E-7 V	10:1
	+1.5000 mV	+1.4959 mV	_____	+1.5041 mV	4.1E-7 V	10:1
	+2.3000 mV	+2.2958 mV	_____	+2.3042 mV	4.2E-7 V	10:1
	+3.0000 mV	+2.9957 mV	_____	+3.0043 mV	4.2E-7 V	10:1
	.25V	- 13.0000 mV	- 13.0057 mV	_____	- 12.9943 mV	4.9E-7 V
- 9.0000 mV		- 9.0053 mV	_____	- 8.9947 mV	4.7E-7 V	>10:1
- 6.0000 mV		- 6.0050 mV	_____	- 5.9950 mV	4.4E-7 V	>10:1
- 3.0000 mV		- 3.0047 mV	_____	- 2.9953 mV	4.2E-7 V	>10:1
0.0000 mV		- 0.0044 mV	_____	+ 0.0044 mV	4.0E-7 V	>10:1
+ 3.0000 mV		+ 2.9953 mV	_____	+ 3.0047 mV	4.2E-7 V	>10:1
+ 6.0000 mV		+ 5.9950 mV	_____	+ 6.0050 mV	4.4E-7 V	>10:1
+ 9.0000 mV		+ 8.9947 mV	_____	+ 9.0053 mV	4.7E-7 V	>10:1
+13.0000 mV		+12.9943 mV	_____	+13.0057 mV	4.9E-7 V	>10:1
1.0V		- 50.0000 mV	- 50.0103 mV	_____	- 49.9897 mV	7.5E-7 V
	- 37.5000 mV	- 37.5090 mV	_____	- 37.4910 mV	6.6E-7 V	>10:1
	- 25.0000 mV	- 25.0078 mV	_____	- 24.9922 mV	5.8E-7 V	>10:1
	- 13.0000 mV	- 13.0066 mV	_____	- 12.9934 mV	4.9E-7 V	>10:1
	0.0000 mV	- 0.0053 mV	_____	+ 0.0053 mV	4.0E-7 V	>10:1
	+13.0000 mV	+12.9934 mV	_____	+13.0066 mV	4.9E-7 V	>10:1
	+25.0000 mV	+24.9922 mV	_____	+25.0078 mV	5.8E-7 V	>10:1
	+37.5000 mV	+37.4910 mV	_____	+37.5090 mV	6.6E-7 V	>10:1
	+50.0000 mV	+49.9897 mV	_____	+50.0103 mV	7.5E-7 V	>10:1
	4.0V	- 200.000 mV	- 200.029 mV	_____	- 199.971 mV	1.6E-6 V
- 150.000 mV		- 150.024 mV	_____	- 149.976 mV	1.4E-6 V	>10:1
- 100.000 mV		- 100.019 mV	_____	- 99.981 mV	1.2E-6 V	>10:1
- 50.000 mV		- 50.014 mV	_____	- 49.986 mV	1.0E-6 V	>10:1
0.000 mV		- 0.009 mV	_____	+ 0.009 mV	0.8E-6 V	10:1
+ 50.000 mV		+ 49.986 mV	_____	+ 50.014 mV	1.0E-6 V	>10:1
+100.000 mV		+ 99.981 mV	_____	+100.019 mV	1.2E-6 V	>10:1
+150.000 mV		+149.976 mV	_____	+150.024 mV	1.4E-6 V	>10:1
+200.000 mV		+199.971 mV	_____	+200.029 mV	1.6E-6 V	>10:1
16.0V		- 800.000 mV	- 800.117 mV	_____	- 799.883 mV	4.0E-6 V
	- 600.000 mV	- 600.097 mV	_____	- 599.903 mV	3.2E-6 V	>10:1
	- 400.000 mV	- 400.077 mV	_____	- 399.923 mV	2.4E-6 V	>10:1
	- 200.000 mV	- 200.057 mV	_____	- 199.943 mV	1.6E-6 V	>10:1
	0.000 mV	- 0.037 mV	_____	+ 0.037 mV	0.8E-6 V	>10:1
	+200.000 mV	+199.943 mV	_____	+200.057 mV	1.6E-6 V	>10:1
	+400.000 mV	+399.923 mV	_____	+400.077 mV	2.4E-6 V	>10:1
	+600.000 mV	+599.903 mV	_____	+600.097 mV	3.2E-6 V	>10:1
	+800.000 mV	+799.883 mV	_____	+800.117 mV	4.0E-6 V	>10:1

Table 2-1. Performance Test Record for the HP E1415A and HP E1419A (Page 30 of 37)

Test 2-21: DCV Output Accuracy - E1531A 8-Channel Voltage Output SCP						
Ctrl Range	Output	Minimum	Measured	Maximum	M.U.	TAR
16V	-15.50V	-15.5067V	_____	-15.4933V	1.23E-4 V	>10:1
	-5.00V	-5.0046V	_____	-4.9954V	2.10E-5 V	>10:1
	0.00V	-0.0036V	_____	0.0036V	5.00E-7 V	>10:1
	5.00V	4.9954V	_____	5.0046V	2.10E-5 V	>10:1
	15.50V	15.4933V	_____	15.5067V	1.23E-4 V	>10:1

Test 2-22: DCI Output Accuracy - E1532A 8-Channel Current Output SCP						
Ctrl Range	Output	Minimum	Measured	Maximum	M.U.	TAR
10 mA	-9.5 mA	-9.5090 mA	_____	-9.4910 mA	1.93E-4 mA	>10:1
	-5.0 mA	-5.0066 mA	_____	-4.9934 mA	1.25E-4 mA	>10:1
	0.0 mA	-0.0033 mA	_____	0.0033 mA	5.00E-5 mA	>10:1
	5.0 mA	4.9934 mA	_____	5.0066 mA	1.25E-4 mA	>10:1
	9.5 mA	9.4910 mA	_____	9.5090 mA	1.93E-4 mA	>10:1

Table 2-1. Performance Test Record for the HP E1415A and HP E1419A (Page 31 of 37)

Test 2-23: Digital I/O Verification - E1533A Digital Input/Output SCP		
Channel 100 OUTPUT	Channel 101 INPUT	
1	PASS _____	FAIL _____
2	PASS _____	FAIL _____
4	PASS _____	FAIL _____
8	PASS _____	FAIL _____
16	PASS _____	FAIL _____
32	PASS _____	FAIL _____
64	PASS _____	FAIL _____
128	PASS _____	FAIL _____
0	PASS _____	FAIL _____
255	PASS _____	FAIL _____
Channel 101 OUTPUT	Channel 100 INPUT	
1	PASS _____	FAIL _____
2	PASS _____	FAIL _____
4	PASS _____	FAIL _____
8	PASS _____	FAIL _____
16	PASS _____	FAIL _____
32	PASS _____	FAIL _____
64	PASS _____	FAIL _____
128	PASS _____	FAIL _____
0	PASS _____	FAIL _____
255	PASS _____	FAIL _____

Table 2-1. Performance Test Record for the HP E1415A and HP E1419A (Page 32 of 37)

Test 2-24: Accuracy - E1534A 8-Channel Freq/Totalize/PWM SCP					
FREQUENCY COUNTER ACCURACY					
E1534A Input Frequency	Minimum	Measured	Maximum	M.U.	TAR
1 kHz	999.00 Hz	_____	1001.00 Hz	0.005 Hz	>10:1
10 kHz	9989.98 Hz	_____	10010.02 Hz	0.05 Hz	>10:1
50 kHz	49949.88 Hz	_____	50050.12 Hz	0.25 Hz	>10:1
100 kHz	99899.76 Hz	_____	100100.24 Hz	0.5 Hz	>10:1
FREQUENCY SOURCE ACCURACY					
E1534A Output Frequency	Minimum	Measured	Maximum	M.U.	TAR
200 Hz	199.79 Hz	_____	200.21 Hz	0.02 Hz	1.5
10 kHz	9966.16 Hz	_____	10033.84 Hz	1.00 Hz	>10:1
20 kHz	19884.63 Hz	_____	20115.37 Hz	2.00 Hz	>10:1
40 kHz	39578.50 Hz	_____	40421.50 Hz	4.00 Hz	>10:1
PULSE SOURCE ACCURACY					
E1534A Output Pulse	Minimum	Measured	Maximum	M.U.	TAR
1 mS @ 200 Hz	0.9988 mS	_____	1.0012 mS	2.205E-6	>10:1
10 μS @ 10 kHz	9.7898 μS	_____	10.2102 μS	206E-9	1:1
10 μS @ 20 kHz	9.7898 μS	_____	10.2102 μS	206E-9	1:1
10 μS @ 40 kHz	9.7898 μS	_____	10.2102 μS	206E-9	1:1
7.87 μS @ 32 kHz	7.6619 μS	_____	8.0781 μS	206E-9	1:1
492 μS @ 500 Hz	491.3078 μS	_____	492.6922 μS	206E-9	3.4:1

Table 2-1. Performance Test Record for the HP E1415A and HP E1419A (Page 33 of 37)

Test 2-25: Alarm/Time-Out Verification - E1535A Watchdog Timer SCP				
RELAY CLOSURE VERIFICATION				
Relay	Minimum	Measured	Maximum	
relay0	47 Ω		55 Ω	
relay1	47 Ω		55 Ω	
relay2	47 Ω		55 Ω	
relay3	47 Ω		55 Ω	
RELAY OPEN VERIFICATION				
Relay	Minimum	Measured	Maximum	
relay0	OVERLOAD Ω		OVERLOAD Ω	
relay1	OVERLOAD Ω		OVERLOAD Ω	
relay2	OVERLOAD Ω		OVERLOAD Ω	
relay3	OVERLOAD Ω		OVERLOAD Ω	
ALARM TIME-OUT VERIFICATION				
Relay	Relay opens after time-out period?			
	YES	NO		
relay0	_____	_____		
relay1	_____	_____		
relay2	_____	_____		
relay3	_____	_____		

Table 2-1. Performance Test Record for the HP E1415A and HP E1419A (Page 34 of 37)

Test 2-26: Self-Test Verification - E1536A Isolated Digital I/O SCP	
Channels configured for application	
Self-Test passes:	YES _____ NO _____
Channels configured as outputs	
Self-Test passes:	YES _____ NO _____
Channels configured as inputs	
Self-Test passes:	YES _____ NO _____

Test 2-27: DCV Output Accuracy - E1537A Voltage Output SCP						
Ctr Range	Output	Minimum	Measured	Maximum	M.U.	TAR
16V	-15.50V	-15.5067V	_____	-15.4933V	1.23E-4 V	>10:1
	-5.00V	-5.0046V	_____	-4.9954V	2.10E-5 V	>10:1
	0.00V	-0.0036V	_____	0.0036V	5.00E-7 V	>10:1
	5.00V	4.9954V	_____	5.0046V	2.10E-5 V	>10:1
	15.50V	15.4933V	_____	15.5067V	1.23E-4 V	>10:1

Table 2-1. Performance Test Record for the HP E1415A and HP E1419A (Page 35 of 37)

Test 2-28: Accuracy - E1538A 8-Channel Freq/Totalize/PWM SCP					
E1538A FREQUENCY COUNTER ACCURACY					
Input Frequency	Minimum	Measured	Maximum	M.U.	TAR
1 kHz	999.88 Hz	_____	1000.12 Hz	0.005 Hz	>10:1
10 kHz	9998.76 Hz	_____	10001.24 Hz	0.05 Hz	>10:1
50 kHz	49993.81 Hz	_____	50006.19 Hz	0.25 Hz	>10:1
100 kHz	99987.62 Hz	_____	100012.38 Hz	0.5 Hz	>10:1
E1538A FREQUENCY SOURCE ACCURACY					
E1538A Output Frequency	Minimum	Measured	Maximum	M.U.	TAR
200 Hz	199.97 Hz	_____	200.03 Hz	0.02 Hz	1.5
10 kHz	9975.16 Hz	_____	10024.84 Hz	1.00 Hz	>10:1
20 kHz	19902.63 Hz	_____	20097.37 Hz	2.00 Hz	>10:1
40 kHz	39614.50 Hz	_____	40385.50 Hz	4.00 Hz	>10:1
E1538A PULSE SOURCE ACCURACY					
E1538A Output Pulse	Minimum	Measured	Maximum	M.U.	TAR
1 mS @ 200 Hz	0.9997 mS	_____	1.0003 mS	2.205E-6	>10:1
10 μ S @ 10 kHz	9.7988 μ S	_____	10.2012 μ S	206E-9	1:1
10 μ S @ 20 kHz	9.7988 μ S	_____	10.2012 μ S	206E-9	1:1
10 μ S @ 40 kHz	9.7988 μ S	_____	10.2012 μ S	206E-9	1:1
7.87 μ S @ 32 kHz	7.6690 μ S	_____	8.0710 μ S	206E-9	1:1
492 μ S @ 500 Hz	491.7506 μ S	_____	492.2494 μ S	206E-9	1.2:1
E1538A PULSE WIDTH MEASUREMENT ACCURACY					
Input Pulse	Minimum	Measured	Maximum	M.U.	TAR
3 μ S @ 166666 Hz	2.8374 μ S	_____	3.1626 μ S	0.027 nS	>10:1
1 mS @ 500 Hz	0.9988 mS	_____	1.0012 mS	20.00 nS	>10:1
0.1 S @ 5 Hz	0.0999 S	_____	0.1001 S	0.50 μ S	>10:1

Table 2-1. Performance Test Record for the HP E1415A and HP E1419A (Page 35 of 37)

Test 2-28: Accuracy - E1538A 8-Channel Freq/Totalize/PWM SCP					
E1538A VRS INPUT CIRCUIT FUNCTIONAL VERIFICATION					
E1538A Input Frequency	Minimum	Measured	Maximum	M.U.	TAR
1 kHz	999.90 Hz	_____	1000.10 Hz	0.005 Hz	>10:1
10 kHz	9998.98 Hz	_____	10001.02 Hz	0.05 Hz	>10:1
50 kHz	49994.88 Hz	_____	50005.12 Hz	0.25 Hz	>10:1
100 kHz	99989.76 Hz	_____	100010.24 Hz	0.5 Hz	>10:1

Introduction

The procedures in this chapter show how to electronically adjust the HP E1415A or E1419A to compensate for source voltage and reference resistor offsets.

Recommended Equipment & Environment

A digital multimeter (DMM) is required for the procedures in this chapter. The HP 3458A is the recommended DMM. Before performing these procedures, allow the test equipment and DUT to warm up for at least one hour. The temperature should be within $\pm 1^\circ\text{C}$ of the temperature of the most recent calibration.

Flash Memory Access

The Flash Memory Protect Jumper (JM 2201) (see Figure 3-1 for location) is shipped in the "PROG" position. If the jumper is changed to the "PROTECT" position, you will not be able to store new calibration constants into Flash Memory (Electrically Erasable Programmable Read Only Memory or EEPROM). If the adjustment program shown in this chapter displays an error message, you may need to change the jumper to the PROG position and rerun the program.

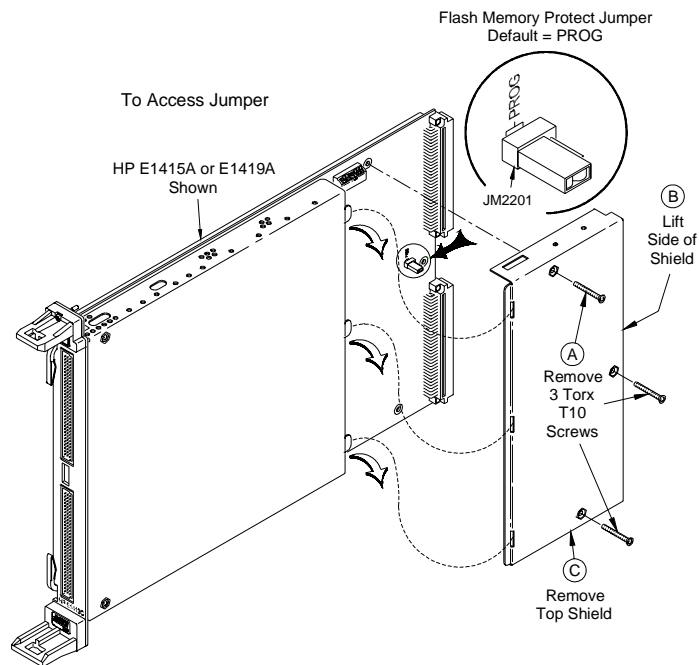

Figure 3-1. Flash Memory Protect Jumper

A/D Adjustment Procedure

This adjustment performs internal A/D adjustments using the CAL:CONF, CAL:VAL, and CAL:STOR commands. (See *Appendix C - Command Reference* for command descriptions.)

Description

The adjustment procedure consists of measuring the values of the 7.5 k Ω reference resistor and voltage source with an external DMM and then entering the values into HP E1415A or E1419A RAM. After the new values have been entered into RAM, they can be stored in Flash Memory (Electrically Erasable Programmable Read Only Memory or EEPROM). See Figure 3-2 for commands and steps. You can perform these adjustments using either the Cal Bus connectors on the HP E1415A or E1419A front panel or the HOHM, LOHM, HCAL, and LCAL connectors on the terminal block.

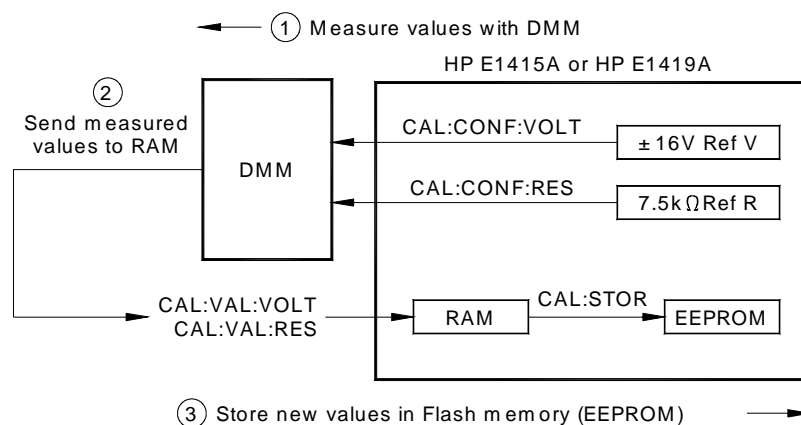

Figure 3-2. Adjustments

Equipment Setup

- Perform an autocalibration on the HP 3458A DMM (unless an autocal has been performed within the last 24 hours).
- Connect the equipment as shown in Figures 3-3 through 3-6, using the connections on the terminal module or the Cal Bus connections on the HP E1415A or E1419A front panel.

Note The HP E1415/E1419 provides a negative current source. The HOHM and LOHM must be inverted at the DMM connecting HOHM to the DMM LO Ohms Sense and LOHM to the DMM HI Ohms Sense.

- If you use the Cal Bus connections, remove the terminal module and make connections between the DMM and HP E1415A or E1419A #1. You can use the 555 mm (22 inch) calibration cable supplied.
- To adjust two or more HP E1415As or E1419As (one at a time), connect additional HP E1415As or E1419As (in adjacent mainframe slots) using the 60 mm (2.4 inch) connecting cable supplied.

DC Voltage and Resistance Measurements - HP 3458A or E1410A Multimeters to Cal Bus Connections

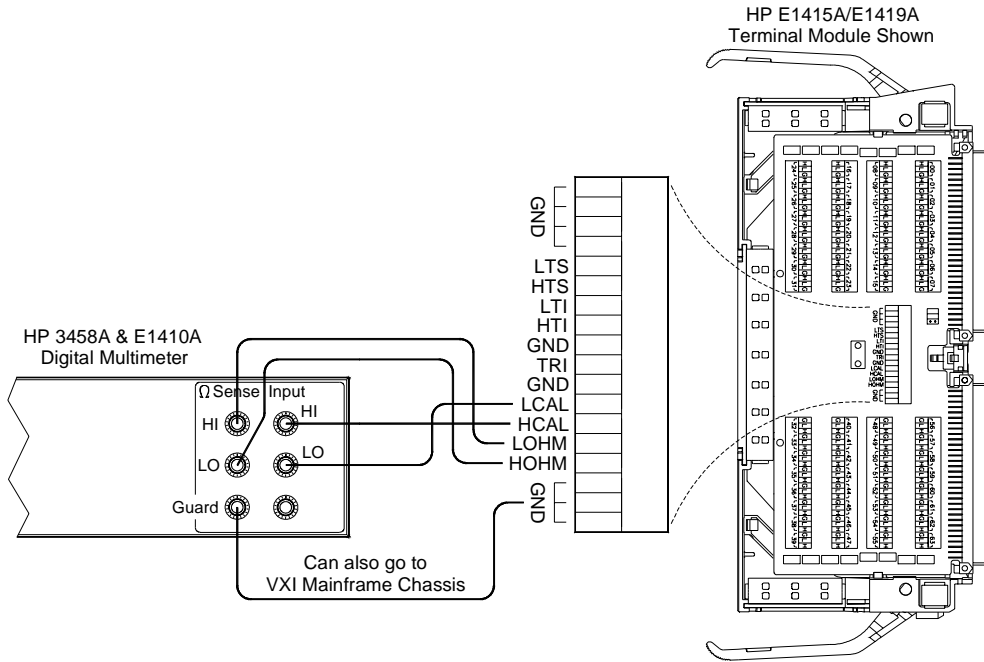

Figure 3-3. Terminal Module Connections

DC Voltage and Resistance Measurements - HP 3458A or E1410A Multimeters to Cal Bus Connections

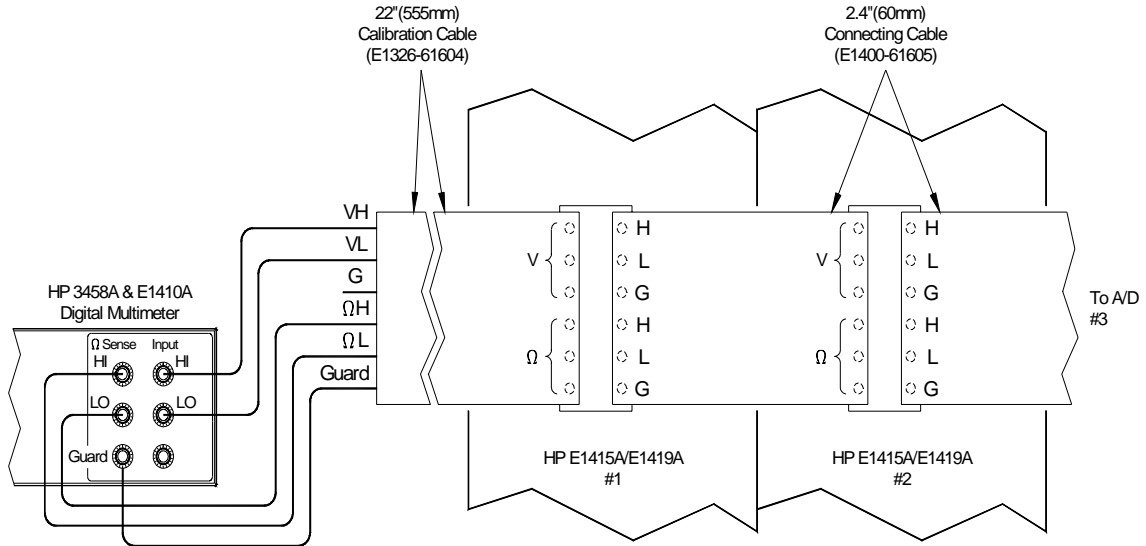

Figure 3-4. Cal Bus Connections

DC Voltage and Resistance Measurements - HP 3457A or 34401A Multimeters to Terminal Module

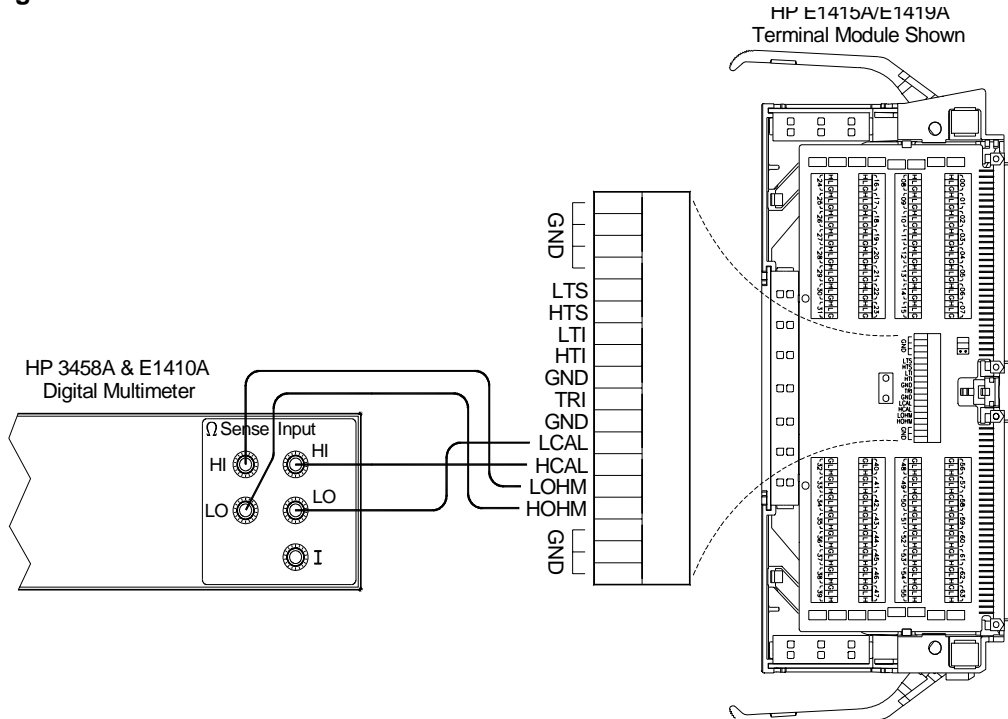

Figure 3-5. Terminal Module Connections

DC Voltage and Resistance Measurements - HP 3457A or 34401A Multimeters to Cal Bus Connections

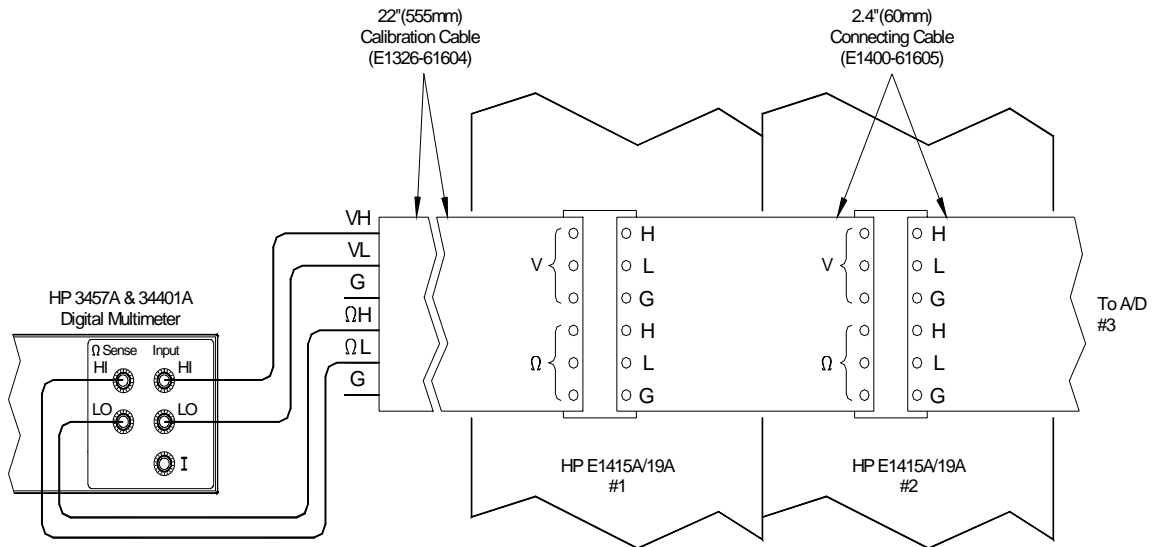

Figure 3-6. Cal Bus Connections

DC Voltage and Resistance Measurements - HP E1326A or E1411A Multimeters to Terminal Module

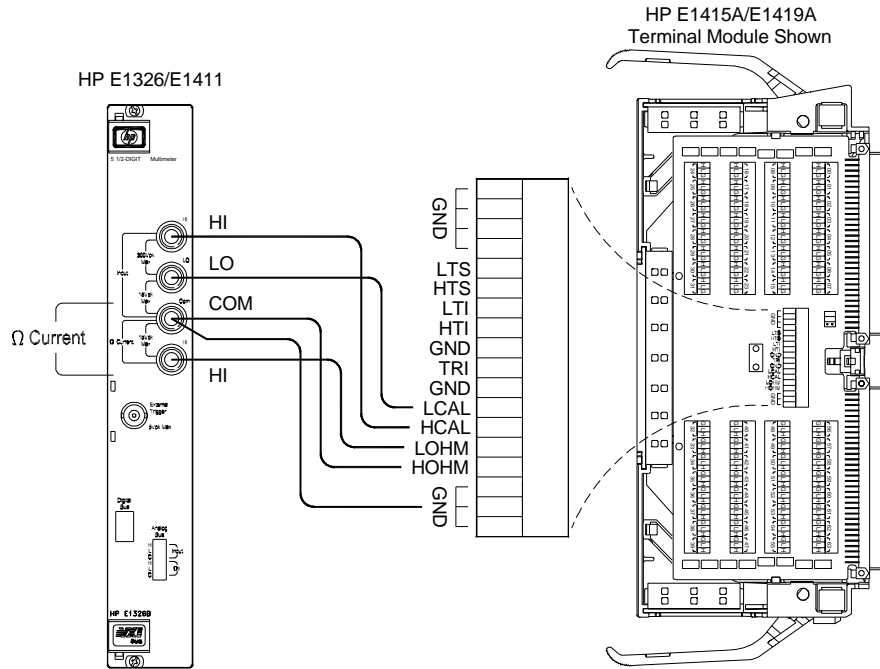

Figure 3-7. Terminal Module Connections

DC Voltage and Resistance Measurements - HP E1326A or E1411A Multimeters to Cal Bus Connections

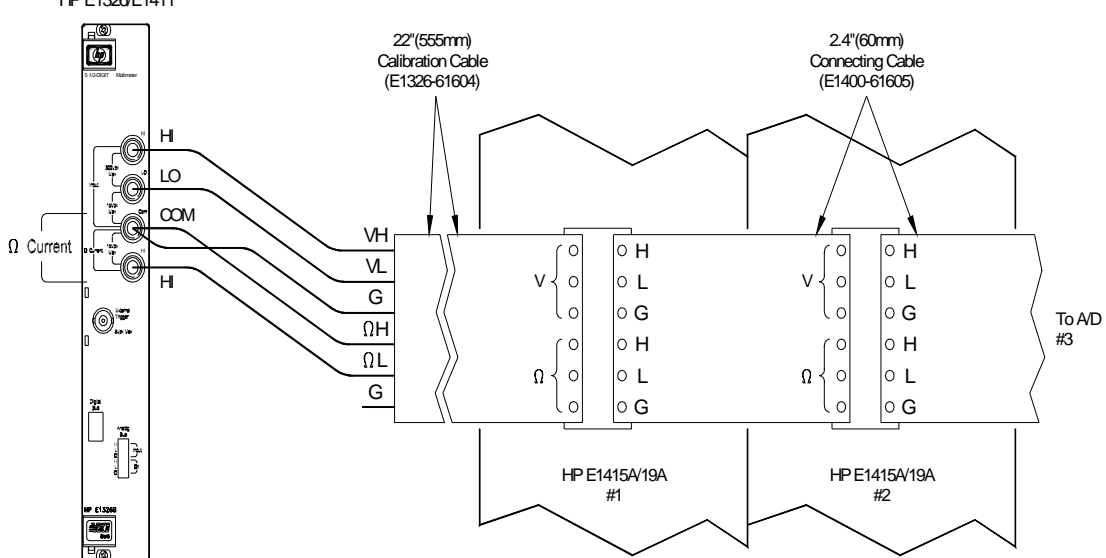

Figure 3-8. Cal Bus Connections

Adjustment Procedure

This procedure adjusts the HP E1415A or E1419A using the HP 3458A DMM for external measurements.

Note As shipped from the factory, the Flash Memory Protect Jumper (JM 2201) is set to the "PROG" position. If the jumper is NOT set to the PROG position, values cannot be loaded into Flash memory and the following error messages are displayed. If required, change the jumper setting to the PROG position (see Figure 3-1) and then rerun the adjustment procedure.

Error Messages

+3034,"0x4: DSP-Flash ROM erase failure"
+3035,"0x8: DSP-Programming voltage not present"
"+0, No error"

1 Perform DMM Autocalibration

[a] As required, perform an autocalibration on the HP 3458A DMM

ACAL ALL *Perform DMM autocalibration*

[b] If autocal is not required, go to Step 2

2 Measure Reference Resistance

[a] Make 4-wire resistance connections (see Figures 3-3 through 3-8)

[b] Set HP E1415A or E1419A to measure resistance

*RST;*CLS;*OPC? *Reset HP E1415A or E1419A and clear status register*
CAL:CONF:RES;*OPC? *Set for resistance measurements. Use *OPC? and ENTER to ensure HP E1415A or E1419A setup is complete*

ENTER statement

[c] Set and Trigger DMM

RESET *Reset DMM*
FUNC OHMF *Set 4-wire ohms*
OCOMP ON *Set offset compensation*
NPLC 20 *Set NPLC 20*
WAIT 1 *Wait 1 second*
TRIG SGL *Trigger DMM*
ENTER <ref_ohms> *Measure value of reference resistor*

[d] Send measured value to HP E1415A or E1419A

CAL:VAL:RES <ref_ohms> *Send ref resistor value to E1415A RAM*

3 Source Voltage Measurements

[a] Make DCV connections (see Figures 3-3 through 3-8)

[b] Reset HP E1415A or E1419A

*RST;*CLS;*OPC?

*Reset HP E1415A or E1419A
and clear status register*

[c] Set DMM

RESET
NPLC 20

*Set DMM for DCV, autorange
Set NPLC 20*

Note When measuring with the HP 3458A on the 16 V range, the E1415A/19A's source is ~10 V. Ensure the HP 3458A is on its 10V range, the 100V range loads the source.

[d] Set HP E1415A or E1419A for first voltage measurement

CAL:CONF:VOLT .0625, ZERO

*Connect DMM to source
voltage, set .0625V range and
ZERO source output.*

*OPC?

*Use *OPC? to ensure setup
completed*

ENTER statement

[e] Trigger DMM and Send Voltage Value to RAM

TRIG SGL

*Measure source voltage and
store result in ref_volts*

WAIT 1

ENTER <ref_volts>

[f] Send measured value to HP E1415A or E1419A

CAL:VAL:VOLT <ref_volts>

*Send meas value to E1415/19
RAM*

Note CAL:VAL:VOLT <ref_volts> value may need adjusting for improved accuracy. For example, the E1415A/E1419A source impedance is 470 Ω . Placing the 10M Ω impedance of the HP 3457A or E1410A DMM across the source (see Figure 3-9) when measuring the 4V or 16V A/D range reduces the reading accuracy. For this example, multiply the DMM reading by 1.000047 to get the true <ref_volts> value to send to the E1415A or E1419A RAM.

Perform voltage measurements for all ranges/levels in order shown below:

Range	Level	Range	Level
.0625V	ZERO	4.0V	ZERO
.0625V	FULL-SCALE	4.0V	FULL-SCALE
.25V	ZERO	16.0V	ZERO
.25V	FULL-SCALE	16.0V	FULL-SCALE
1.0V	ZERO		
1.0V	FULL-SCALE		

4 Store Results in Flash Memory

CAL:STOR ADC

Store new resistance and voltage calibration constants in Flash memory

Adjustment Program

Run the "ADJSPROC" program to perform A/D adjustments for an HP E1415A or E1419A. For this program, an HP 3458A DMM is used to measure the reference resistor and reference voltage values. A typical display for the ADJSPROC program follows.

A/D Adjustments (ADJSPROC) Typical Results

Measured Voltage Values

1. Voltage should be ~90% FULL-SCALE range (except 16V range).
2. For the 16V range, voltage value should be ~10.0V.

Range (V)	Level	Measured (V)	% of Full-Scale
.0625	ZERO	.0001	
.0625	FSC	.0564	90.3
.2500	ZERO	.0001	
.2500	FSC	.2253	90.1
1.0000	ZERO	.0001	
1.0000	FSC	.8941	89.4
4.0000	ZERO	.0001	
4.0000	FSC	3.5988	90.0
16.0000	ZERO	.0001	
16.0000	FSC	10.0035	62.5

Resistance Value: 7.4981 Kohms

Chapter 4

Replaceable Parts

Introduction

This chapter contains information to order replaceable parts and/or exchange modules for the HP E1415A, the HP E1419A, and the Signal Conditioning Plug-Ons (SCPs).

Exchange Modules

Table 4-1 lists modules described in this manual that may be replaced on an exchange basis (Exchange Modules). Exchange modules are available only on a trade-in basis. Defective modules must be returned for credit. Order modules for spare parts stock by the new module part number.

Table 4-1. E1415A and HP E1419A - Exchange/New Modules

Module	Exchange Part Number	New Part Number
E1415A	E1415-69201	E1415-66201
E1419A	E1419-69201	E1419-69201
Terminal Block Module	N/A	E1415-80011

Replaceable Parts Lists

Table 4-4 lists replaceable parts for the HP E1415A and the HP E1419A. See "Component Locators" (Figures 4-1 through 4-4) for locations of parts. Table 4-2 shows reference designators for parts in Table 4-4 and Table 4-3 shows the manufacturer code list for these parts.

Table 4-5 lists replacement part numbers for the Signal Conditioning Plug-Ons (SCPs).

Note If an HP E1415A or HP E1419A defect can be traced to a fuse or replaceable mechanical part, replace the fuse and/or part and retest the module. If the defect cannot be traced to a fuse or replaceable mechanical part, replace the entire module.

Table 4-2. HP E1415A and HP E1419A Reference Designators

Reference Designators		
A assembly	Jelectrical connector (jack)	S switch (rotary)
CBL cable	JMjumper	SCR screw
F fuse	MP misc. mech part	SHD shield
HDmisc hardware	P electrical conn (plug)	SP switch (push-button)
	PNL panel	TP test connector

Table 4-3. HP E1415A and HP E1419A Code List of Manufacturers

Mfr Code	Manufacturer Name	Manufacturer Address			Zip Code
00779	Amp Inc	Harrisburg	PA	US	17111
05791	Lyn-Tron Inc	Burbank	CA	US	91505
26742	Methode Electronics Inc	Chicago	IL	US	60656
28480	Hewlett-Packard Co - Corporate	Palo Alto	CA	US	94304
30817	Instrument Specialties Co Inc	Del Water Gap	PA	US	18327
75915	Littelfuse Inc	Des Plaines	IL	US	60016
81073	Grayhill Inc	La Grange	IL	US	60525
83486	Elco Industries Inc	Rockford	IL	US	61125
91662	Elco Corp	Newport Beach	CA	US	92660

Component Locators

Figures 4-1 through 4-4 shows locations of selected replaceable parts for the E1415A and the HP E1419A. For the Signal Conditioning Plug-Ons (SCPs), replace the complete SCP assembly.

Table 4-4. HP E1415A and HP E1419A Replaceable Parts

Reference Designator	HP Part Number	Qty	Description	Mfr Code	Mfr Part Number
HP E1415A/E1419A HARDWARE PARTS (FIG 4-1)					
CBL1	E1326-61604	1	CONNECTOR CABLE	28480	E1326-61604
CBL2	E1400-61605	1	CALIBRATION CABLE	28480	E1400-61605
HDL1	E1400-45102	1	HANDLE BOTTOM	28480	E1400-45102
HDL2	E1400-45101	1	HANDLE TOP	28480	E1400-45101
PNL1	E1415-00201	1	FRONT PANEL, E1415A	28480	E1415-00201
PNL1	E1419-00201	1	FRONT PANEL, E1419A	28480	E1419-00201
SCR5-SCR9	0515-1135	5	SCREW-M3 X 0.5 25MM-LG FLAT-HEAD	28480	0515-1135
SCR10-SCR11	0515-0664	2	SCREW-M3.0 X 12MM	28480	0515-0664
SCR12-SCR13	0515-0430	2	SCREW-M3.0 X 6MM	28480	0515-0430
SHD1	E1415-00601	1	TOP SHIELD, E1415A	28480	E1415-00601
SHD1	E1419-00601	1	TOP SHIELD, E1419A	28480	E1419-00601
SHD2	E1413-00602	1	BOTTOM SHIELD	28480	E1413-00602
SHD3	E1415-00603	1	COVER SCP, E1415A	28480	E1415-00603
SHD3	E1419-00603	1	COVER SCP, E1419A	28480	E1419-00603
SHD4	E1415-00604	1	INNER SHIELD	28480	E1415-00604
A1 PCA REPLACEABLE PARTS (FIG 4-2)					
PCA1	E1415-66501	1	PRINTED CIRCUIT ASSEMBLY, E1415A/E1419A	28480	E1415-66501
F103,F106	2110-0932	2	FUSE-SUBMINIATURE 5A 125V	75915	R251004T1
F101,102,104,105	2110-0936	4	FUSE-SUBMINIATURE 4A 125V	28480	2110-0936
J1-J2,P1-P2	1251-7799	4	CONN-POST TYPE 2.54-PIN-SPCG 96-CONTACT	91662	10-8457-096-002-037
J3	1252-0776	1	CONN-POST TYPE .100-PIN-SPCG 12-CONTACT	00779	102979-6
J4100-J4470 ^a	1252-4618	8	50-PIN CONNECTOR 104549-7	00779	104549-7
J4101-J4471 ^b	1252-5357	8	50-PIN RECEPTACLE 104550-6	00779	104550-6
JM2201	1251-4682	1	CONN-POST TYPE .100-PIN-SPCG 3-CONTACT	26742	1102-1-103-02
K4100-K4463 ^c	0490-1937	67	RELAY 2C 3VDC COIL 1A 125VAC	28480	0490-1937
SP1	3101-2243	1	SWITCH-DIP ROCKER 8-1A 0.05A 30VDC	81073	76YY22318S
TERMINAL CASE ASSEMBLY PARTS (FIG 4-3)					
MP1	E1400-45103	1	TOP LEVER	28480	E1400-45103
MP2	E1400-45104	1	BOTTOM LEVER	28480	E1400-45104
MP3	1460-2552	1	TORSION SPRING LEFT WOUND	28480	1460-2552
MP4	1460-2553	1	TORSION SPRING RIGHT WOUND	28480	1460-2553
MP5	E1400-44109	1	CVR-BTM TRM HSG	28480	E1400-44109
MP6	1390-1026	2	STUD QUICK FASTENER	28480	1390-1026
MP7	1390-1027	2	RECEPTICAL QUICK FASTENER	28480	1390-1027
MP8	E1400-04117	1	CVR KIT TERMINAL BLOCK	28480	E1400-04117
MP9	E1400-04116	1	TOP COVER	28480	E1400-04116
TERMINAL BLOCK PC A PARTS (FIG 4-4)					
A1	E1415-66510	1	TERMINAL CARD PC ASSEMBLY	28480	E1415-66510
JM1	1251-6001	1	CONNECTOR POST TP 2 X 3P	28480	1251-6001
P1-P2	1252-1593	2	CONNECTOR-RA RCPT, 96P	28480	1252-1593
TB1	0360-2574	1	TERMINAL BLOCK 18 POS	28480	0360-2574
TB2-TB9	0360-2577	8	TERMINAL BLOCK 24 POS	28480	0360-2577

a. Includes J4100, J4110, J4220, J4230, J4340, J4350, J4460, and J4470

b. Includes J4101, J4111, J4221, J4231, J4341, J4351, J4461, and J4471

c. Includes K4100-K4115, K4190-K4192, K4216-K4231, K4332-K4347, and K4448-K4463

Table 4-5. Signal Conditioning Plug-Ons Replacement Assembly

Model Number	HP Part Number	Qty	Description	Mfr Code	Mfr Part Number
E1501A	E1413-66511	1	Direct Input SCP	28480	E1413-66511
E1502A	E1413-66512	1	Low Pass Filter Input SCP	28480	E1413-66512
E1503A	E1413-66513	1	Gain/Filter Input SCP	28480	E1413-66513
E1504A	E1413-66514	1	Breadboard (no tests)	28480	E1413-66514
E1505A	E1413-66515	1	Current Source SCP	28480	E1413-66515
E1506A	E1413-66516	1	120 Ω Strain Gage SCP	28480	E1413-66516
E1507A	E1413-66517	1	350 Ω Strain Gage SCP	28480	E1413-66517
E1508A	E1413-66518	1	Fixed Gain/Filter Input SCP	28480	E1413-66518
E1509A	E1413-66519	1	Fixed Gain/Filter Input SCP	28480	E1413-66519
E1510A	E1413-66520	1	4 Channel Sample & Hold SCP	28480	E1413-66520
E1511A	E1413-66521	1	4 Channel Transient Strain SCP	28480	E1413-66521
E1512A	E1512-66501	1	8 Channel 25Hz Low Pass SCP	28480	E1512-66501
E1513A	E1513-66501	1	Attenuator Input / 16 SCP	28480	E1513-66501
E1514A	E1514-66501	1	Iso x1, 4 Channel 10Hz LP SCP	28480	E1514-66501
E1515A	E1515-66501	1	Iso x1, 4 Channel 100Hz LP SCP	28480	E1515-66501
E1516A	E1516-66501	1	Iso x64, 4 Channel 10Hz LP SCP	28480	E1516-66501
E1517A	E1517-66501	1	Iso x64, 4 Channel 100Hz LP SCP	28480	E1517-66501
E1518A	E1518-66501	1	Resistance Measurement SCP	28480	E1518-66501
E1531A	E1531-66501	1	Voltage Output SCP	28480	E1531-66501
E1532A	E1532-66501	1	Current Output SCP	28480	E1532-66501
E1533A	E1533-66501	1	Digital Input/Output SCP	28480	E1533-66501
E1534A	E1534-66501	1	Freq/Totalize/PWM SCP	28480	E1534-66501
E1535A	E1535-66501	1	Watchdog Timer SCP	28480	E1535-66501
E1536A	E1536-66501	1	Isolated Digital I/O SCP	28480	E1536-66501
E1537A	E1537-66501	1	4 Channel Voltage Output SCP	28480	E1537-66501
E1538A	E1538-66501	1	Advanced Frequency/Totalize SCP	28480	E1538-66501

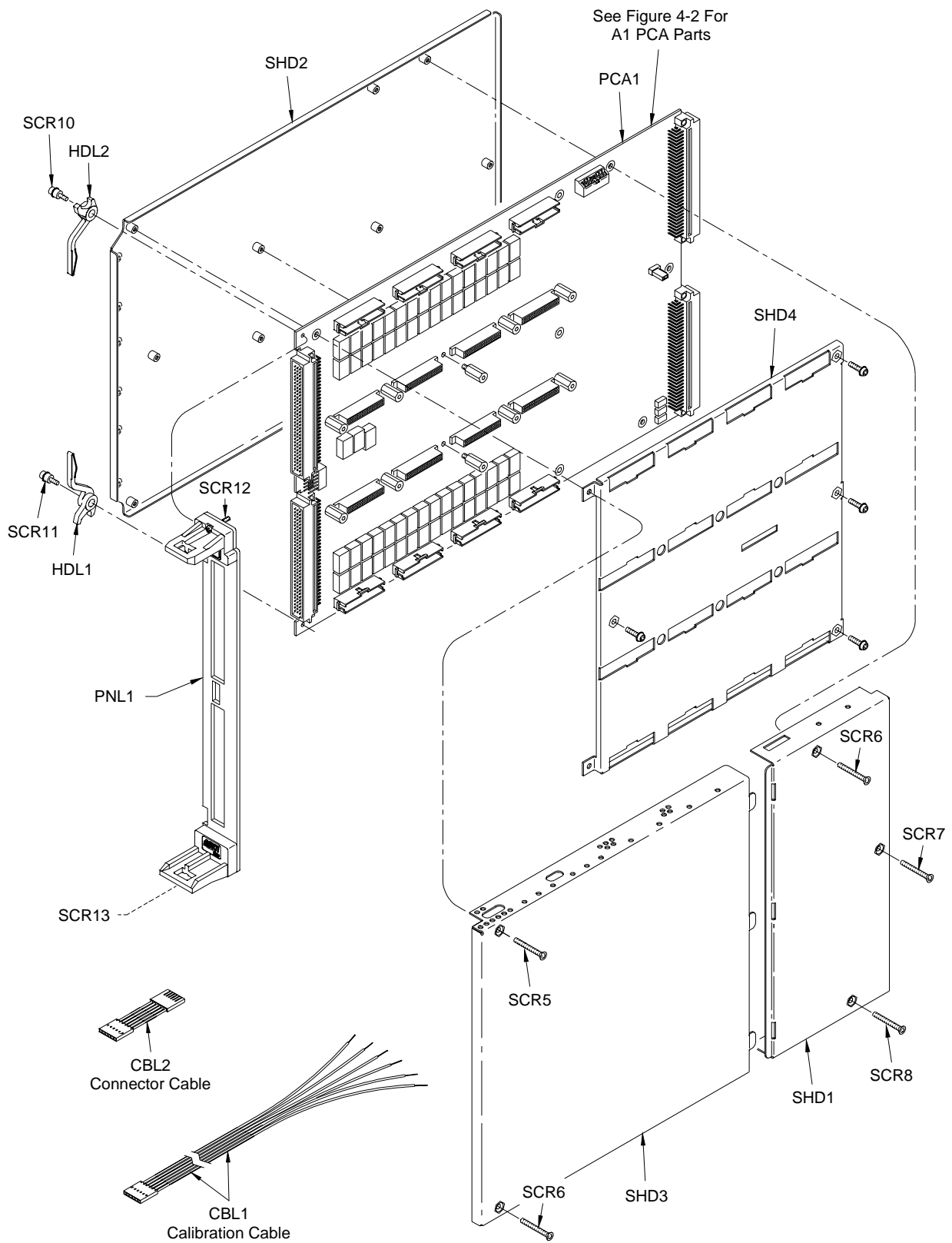

Figure 4-1. HP E1415A/E1419A Mechanical Parts

A1 PCA Relay Number Legend

Ch	Relay	Ch	Relay	Ch	Relay	Ch	Relay	Ch	Relay	Ch	Relay
0	K4100	11	K4111	22	K4222	33	K4333	44	K4344	55	K4455
1	K4101	12	K4112	23	K4223	34	K4334	45	K4345	56	K4456
2	K4102	13	K4113	24	K4224	35	K4335	46	K4346	57	K4457
3	K4103	14	K4114	25	K4225	36	K4336	47	K4347	58	K4458
4	K4104	15	K4115	26	K4226	37	K4337	48	K4448	59	K4459
5	K4105	16	K4216	27	K4227	38	K4338	49	K4449	60	K4460
6	K4106	17	K4217	28	K4228	39	K4339	50	K4450	61	K4461
7	K4107	18	K4218	29	K4229	40	K4340	51	K4451	62	K4462
8	K4108	19	K4219	30	K4230	41	K4341	52	K4452	63	K4463
9	K4109	20	K4220	31	K4231	42	K4342	53	K4453	90	K4190
10	K4110	21	K4221	32	K4332	43	K4343	54	K4454	91	K4191
										92	K4192

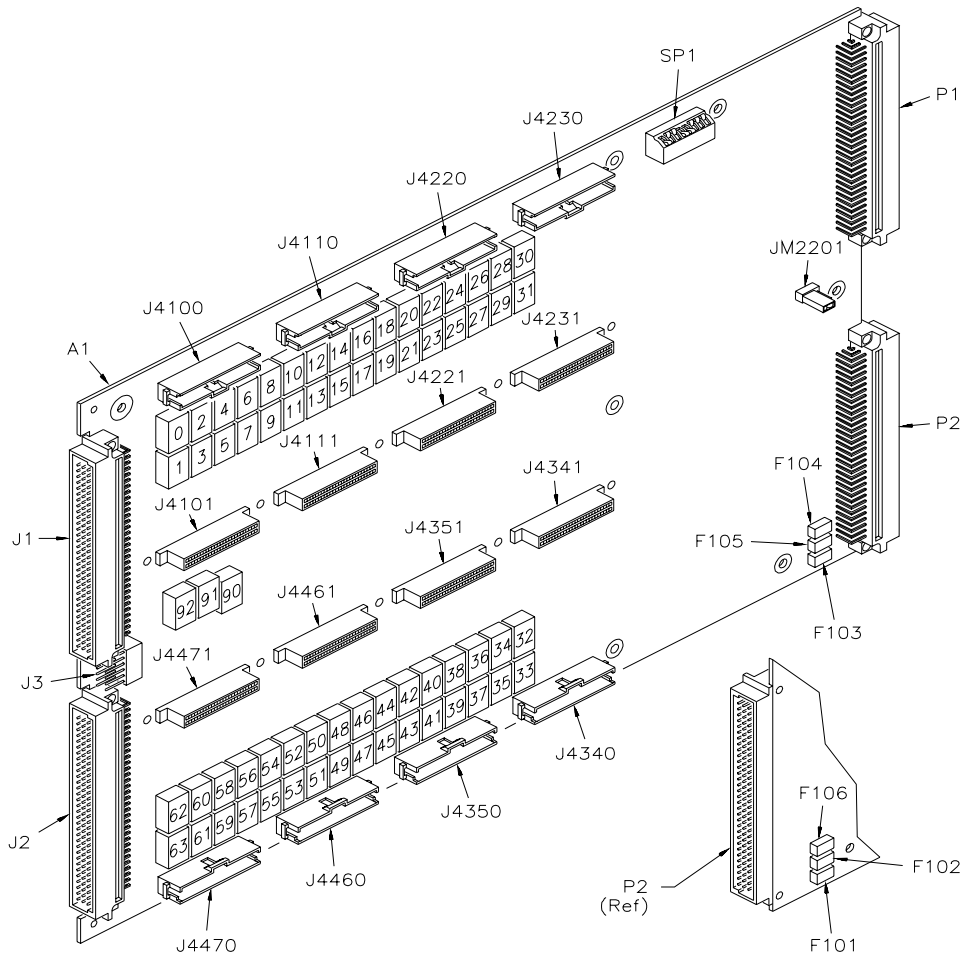

Figure 4-2. HP E1415A/E1419A A1 PCA Replaceable Parts

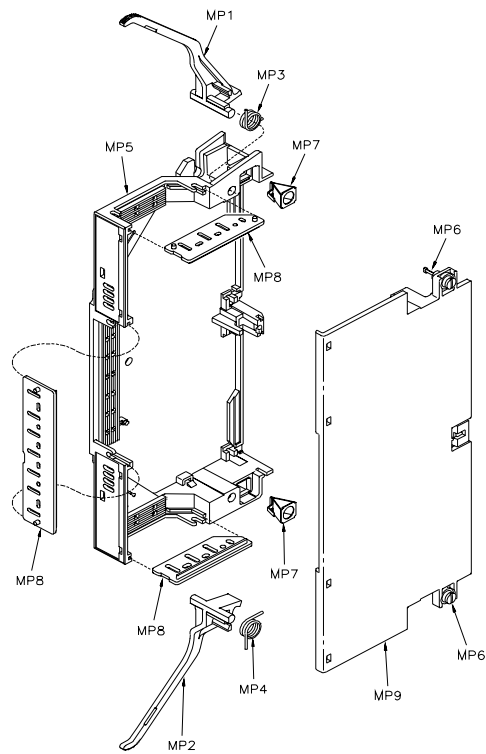

Figure 4-3. HP E1415A/E1419A Terminal Case Parts

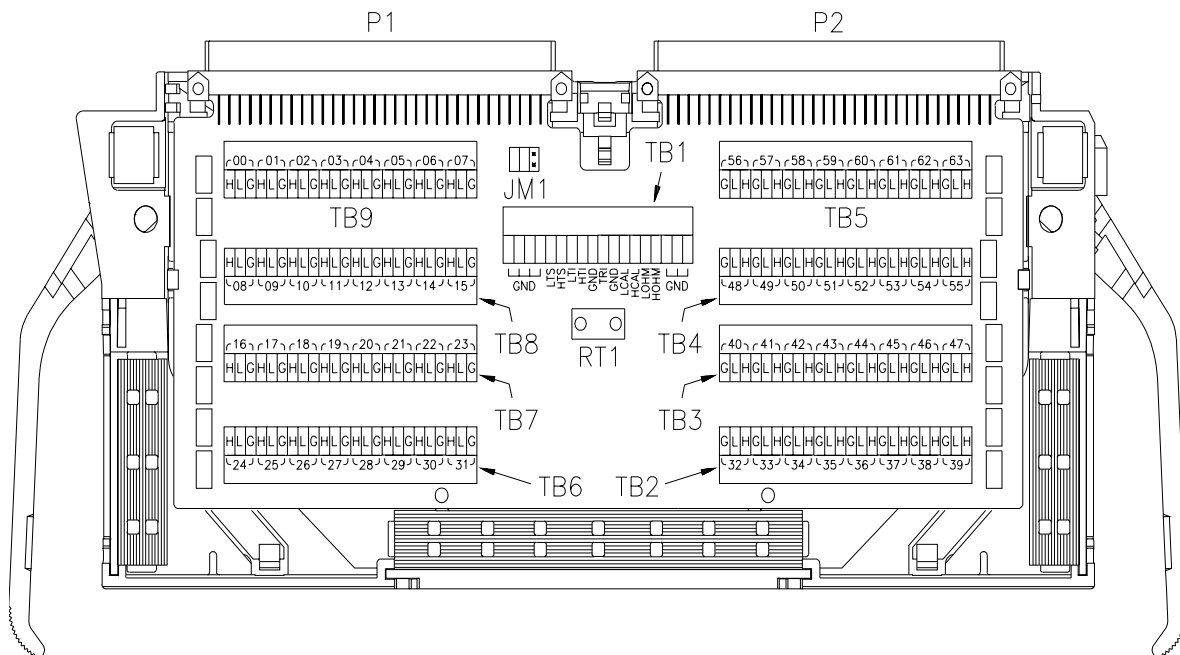

Figure 4-4. HP E1415A/E1419A Terminal Block PC Assembly Parts

Introduction

This chapter contains information to service the HP E1415A or HP E1419A, including recommended repair strategy, troubleshooting guidelines, and disassembly/repair guidelines.

WARNING Do not perform any of the service procedures shown unless you are a qualified, service-trained person, and have read the **WARNINGS** and **CAUTIONS** in Chapter 1.

Equipment Required

Equipment required for HP E1415A or HP E1419A troubleshooting and repair is listed in Table 1-4, *Recommended Test Equipment*. To avoid damage to the screw head slots, use T8 and T10 Torx drivers as described in the "Disassembly" section in this chapter.

Service Aids

See *Chapter 4 - Replaceable Parts* for descriptions and locations of replaceable parts. Service notes and service literature for the HP E1415A and HP E1419A may be available through Hewlett-Packard. For information, contact your nearest Hewlett-Packard Sales and Support Office.

Recommended Repair Strategy

The recommended repair strategy for the HP E1415A and HP E1419A and associated SCPs follows:

- Before replacing an HP E1415A or HP E1419A, check fuses F101 through F106 on the A1 Printed Circuit Assembly (PCA) and check other replaceable parts listed in *Chapter 4 - Replaceable Parts*.
- If the fault can be traced to a part listed in Chapter 4, repair the fault and retest the instrument. If not, exchange or replace the entire HP E1415A, HP E1419A or SCP.

Troubleshooting Guidelines

This section shows suggested steps to troubleshoot HP E1415A or HP E1419A faults to a replaceable part listed in *Chapter 4 - Replaceable Parts*. If the fault cannot be isolated to a replaceable part, do not attempt further repairs. Instead, replace the instrument. The first step in troubleshooting the HP E1415A or HP E1419A is to run the self test (SELFTEST.C) program.

Running Service Test Program

To begin troubleshooting, run the SELFTEST.C program to test the HP E1415A and HP E1419A. If the self-test passes, "Self-test (*TST?) PASSED" is displayed. If the self-test fails, error messages are displayed. Table 5-1 shows suggested actions, depending on the program results.

Note During the first 5 minutes after power is applied, the self-test (*TST?) may fail. Allow the HP E1415A or HP E1419A to warm up before running the SELFTEST.C program.

Table 5-1. HP E1415A and HP E1419A Troubleshooting Steps

If the SELFTEST program result is:	The most likely cause is:	See this section:
+3052, "Self test failed. Check info in FIFO"	SCP is not properly seated or is defective	"Checking SCPs"

For example, the following result for the self-test program indicates test #72 (SCP continuity) failed and channel 100 is the failed channel. See *Appendix C - Command Reference* for a description of the *TST? and SYST:ERR? error messages.

System Error Messages

+3052,"Self test failed. Test info in FIFO"

+0,"No error"

FIFO Error Messages

1 - 99 = Failed test number

100 - 163 = Failed channel number

200 - 204 = Range for failed test

+7.200000E+001,+1.000000E+002

Troubleshooting

If the self-test program does not respond, remove the HP E1415A or HP E1419A from the mainframe and check the items listed in Table 5-2, "HP E1415A or HP E1419A Checks."

Change/repair/replace components as required and then retest the instrument using the SELFTTEST.C program. If the self-test still does not return a response, replace the instrument.

Table 5-2. HP E1415A or HP E1419A Checks

Test/Check	Reference Designator	Check	Comments
Logical Address	SP1	LADDR Switch setting (factory set to 26)	See the <i>HP E1415A or E1419A User's Manual</i> for information on switch settings.
A1 PCA	F101 - F106 J1 - J3, J4100 - J4471, P1 - P2	Fuse continuity Damaged connectors	See "Repair/Maintenance Guidelines" before replacing fuse(s)/connectors. See "Disassembly" to remove covers/shields.
Terminal Module	JM1 MP1 - MP7 P1 - P2 TB1 - TB16	Damaged connectors	See Figures 4-3 and 4-4 for HP E1415A/E1419A terminal block parts locations.

Checking SCPs

Table 5-3 gives some guidelines to check/replace SCPs.

Table 5-3. Guidelines to Check/Replace SCPs

If the SELFTTEST shows failure for test number(s):	Do This:
20, 30 through 37	Remove all SCPs and rerun the SELFTTEST program. If *TST? then passes, replace SCPs one at a time until you find the one causing the problem. Then, replace the SCP.
72, 74 - 76, 80 - 93, 301 - 354	Try to reseat the SCP that the channel number(s) point to and then rerun SELFTTEST. Or, move the SCP and see if the problems follow the SCP. If so, replace the SCP and rerun SELFTTEST.
Other test numbers	Replace the instrument.

Disassembly

To disassemble the HP E1415A or HP E1419A, you will need a T-8 and T-10 Torx driver. See Figure 5-1 for steps to disassemble an HP E1415A or HP E1419A. Reverse the steps to reassemble the HP E1415A or HP E1419A.

Caution Do not handle or disassemble the electronic module unless you are familiar with the precautions listed in the "Repair/Maintenance Guidelines" section of this chapter.

1 Remove Top Shield

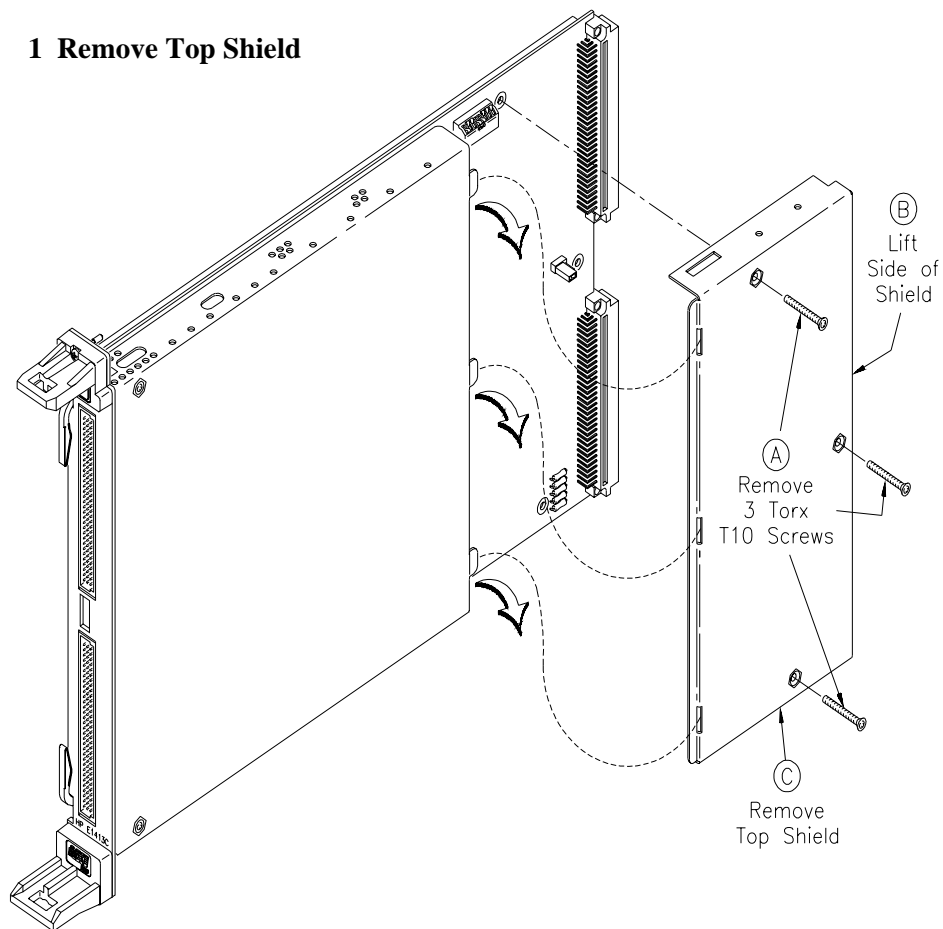
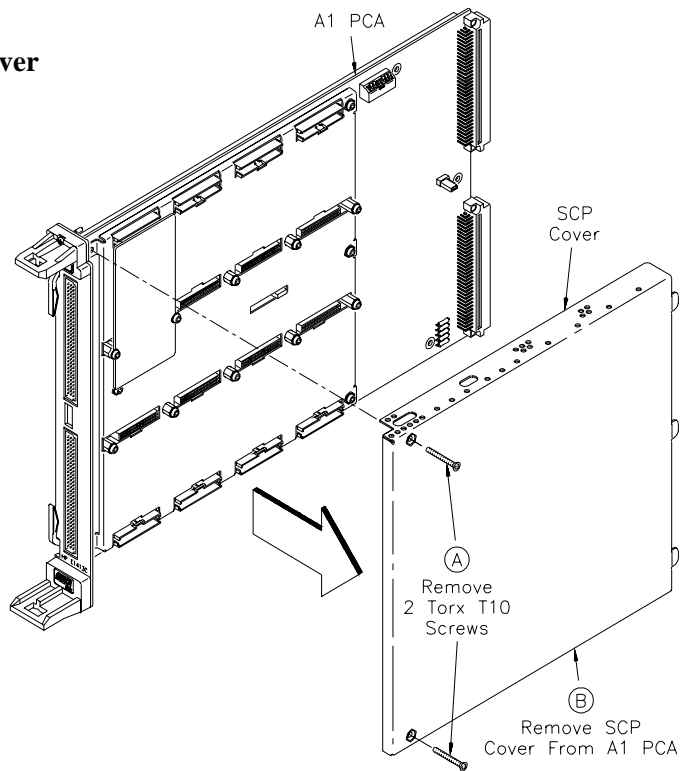

Figure 5-1. HP E1415A and HP E1419A Disassembly

2 Remove SCP Cover



3 Remove SCP(s)

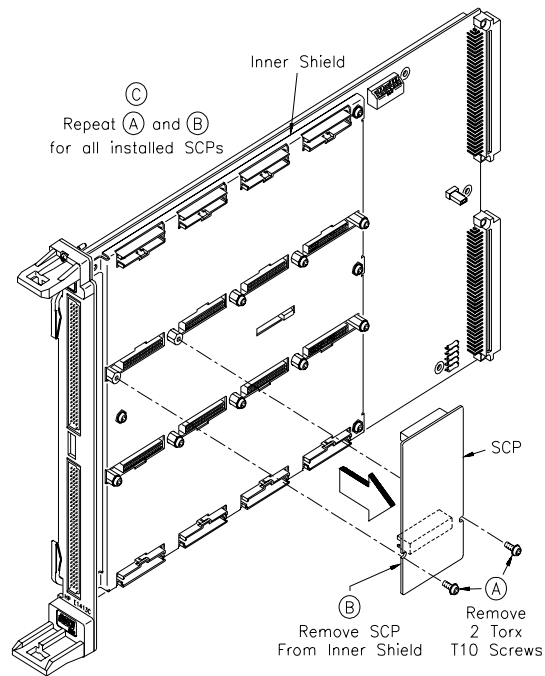
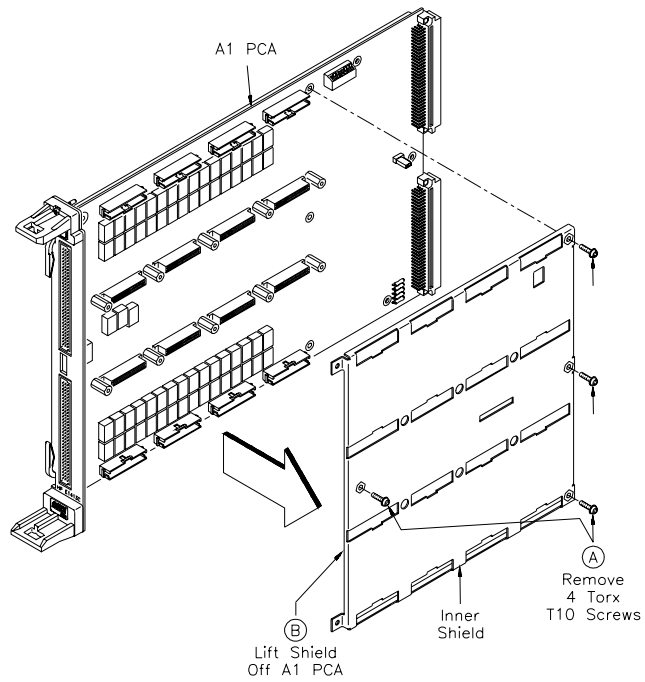

Figure 5-1. HP E1415A and HP E1419A Disassembly (cont'd)

4 Remove Inner Shield



5 Remove A1 PCA

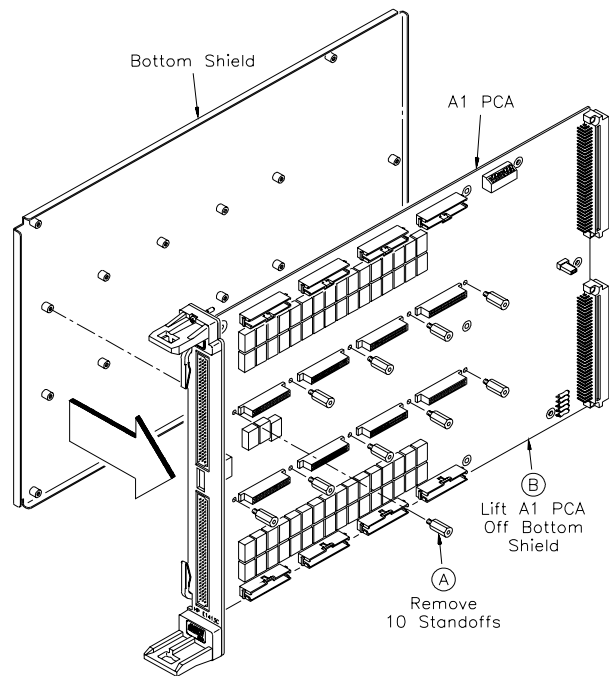

Figure 5-1. HP E1415A and HP E1419A Disassembly (cont'd)

Repair/Maintenance Guidelines

Guidelines to repair and maintain an HP E1415A or HP E1419A follow, including:

- ESD precautions

Caution Do not touch any edge connector pins at any time unless you are actively using a static-free workstation.

ESD Precautions

Electrostatic discharge (ESD) may damage CMOS and other static-sensitive devices in the HP E1415A or HP E1419A such as ROM or RAM ICs. This damage can range from slight parameter degradation to catastrophic failure. When working on HP E1415A, HP E1419A or SCP modules, follow these guidelines to avoid damaging components:

- Always use a static-free work station with a pad of conductive rubber or similar material when handling module components.
- After you remove a module from the frame, place the module on a conductive surface to guard against ESD damage.
- Do not use pliers to remove a CMOS device from a high-grip socket. Instead, use a small screwdriver to pry the device up from one end. Slowly lift the device up, one pair of pins at a time.
- After you remove a CMOS device from a module, place the device onto a pad of conductive foam or other suitable holding material.
- If a device requires soldering, be sure the device is placed on a pad of conductive material. Also, be sure you, the pad, and the soldering iron tip are grounded to the device. Apply as little heat as possible when soldering.

Appendix A

Calculating HP E1415A/19A Accuracy

Introduction

This appendix shows how HP E1415A and HP E1419A accuracy, source equipment measurement uncertainty, and test accuracy ratio (TAR) values are defined and calculated for the performance verification tests for the HP E1415A, HP E1419A and SCP's.

See Table 2-1, "*HP E1415A/E1419A Performance Test Record*" for 90-day specification values of HP E1415A or HP E1419A accuracy, for Datron 4708, HP 3458A DMM measurement uncertainties, HP 3325A Source uncertainties, and for test accuracy ratios (TARs).

Note HP E1415A and HP E1419A accuracy, measurement uncertainty, and test accuracy ratios in Table 2-1 are valid ONLY for the specified test conditions and assumptions described in this manual.

Accuracy Definition **HP E1415A and HP E1419A accuracy** is the expected accuracy of the measurement due ONLY to the HP E1415A or HP E1419A and SCP's. The Minimum entry in Table 2-1 "*HP E1415A/E1419A Performance Test Record*" is the lower value of accuracy, while the Maximum entry is the upper value of accuracy. If a measured reading is between the Minimum and Maximum values in Table 2-1, the test passes for this reading.

Measurement Uncertainty Definition **Measurement Uncertainty** is the expected accuracy of the source used to input signals to the HP E1415A or HP E1419A or the instrument used to measure outputs from the HP E1415A or HP E1419A. A Datron 4708 Autocal Multifunction Standard Option 10 is the source used for DC inputs; an HP 3325A Synthesizer/Function Generator is used for AC inputs and an HP 3458A DMM is the measuring device for outputs, so the measurement uncertainty is that of a Datron 4708, HP 3325A or an HP 3458A DMM.

Test Accuracy Ratio (TAR) Definition **Test Accuracy Ratio (TAR)** for the HP E1415A/HP E1419A is defined by:

$$TAR = \frac{MaximumValue - ExpectedReading}{MeasurementUncertainty}$$

where MaximumValue = largest amount of variation from the expected reading (the input or output), and MeasurementUncertainty is that of the test equipment (Datron Standard or HP 3458A DMM). If a TAR exceeds 10:1, the entry in Table 2-1 "*HP E1415A/E1419A Performance Test Record*" is ">10:1".

HP E1415A and HP E1419A Accuracy Calculations

Performance verification tests accuracy is defined for DC voltage and DC current measurements using the following specifications. These specifications reflect the performance of the HP E1415A or HP E1419A with the Signal Conditioning Plug-on (SCP) attached. The assumed test conditions are:

- 90 days since the last adjustment
- Operating temperature $23^{\circ}\text{C} \pm 1^{\circ}\text{C}$
- At least one hour warm-up time

DCV Accuracy Equations

DC voltage specifications are defined for 90 days @ $23^{\circ}\text{C} \pm 1^{\circ}\text{C}$. Since 400 readings are averaged for each measurement, the 3 sigma noise specification listed in the SCP manuals divided by the square root of 400 (20). Tables A-1 through A-23 list accuracy derivations used for the performance verification test limits.

For example (see Table A-1), with a 3.2 Vdc input and the 4.0V range, DCV accuracy (90-day) for the E1415A with E1501A SCP = $\pm (.01\%$ of reading + $122 \mu\text{V}$ offset error) = $\pm (.0001 \times 3.2 + 122 \times 10^{-6}) = \pm 0.0004 \text{ Vdc}$. Thus, for a 3.2 Vdc input, the Minimum value for the E1501A SCP test in Table 2-1 "HP E1415A/E1419A Performance Test Record" = 3.1996 Vdc and the Maximum value = 3.2004 Vdc.

Table A-1. DCV Accuracy - E1501A SCP (90-day)

Range $\pm \text{FS}$	Linearity % of rdg	Offset error	Noise 3 sigma	Accuracy limits
.0625V	$\pm .01\%$	5.3 μV	18 μV	$\pm [.0001*\text{rdg} + 5.3 \mu\text{V} + 18/20 \mu\text{V}]$
.25V	$\pm .01\%$	10.3 μV	45 μV	$\pm [.0001*\text{rdg} + 10.3 \mu\text{V} + 45/20 \mu\text{V}]$
1.0V	$\pm .01\%$	31 μV	110 μV	$\pm [.0001*\text{rdg} + 31 \mu\text{V} + 110/20 \mu\text{V}]$
4.0V	$\pm .01\%$	122 μV	450 μV	$\pm [.0001*\text{rdg} + 122 \mu\text{V} + 450/20 \mu\text{V}]$
16.0V	$\pm .01\%$	488 μV	1.8 mV	$\pm [.0001*\text{rdg} + 488 \mu\text{V} + 1.8/20 \text{mV}]$

Test Conditions:
 $23^{\circ}\text{C} \pm 1^{\circ}\text{C}$ with *CAL? done after a one-hour warm-up. CAL:ZERO? done within 5 minutes before the measurement.
 Autoranging OFF.
 Temperature coefficients: Gain - 10ppm/ $^{\circ}\text{C}$ after *CAL?. (0-40 $^{\circ}\text{C}$) 0.14 $\mu\text{V}/^{\circ}\text{C}$, (40-55 $^{\circ}\text{C}$) 0.8 $\mu\text{V} + 0.38 \mu\text{V}/^{\circ}\text{C}$

Table A-2. DCV Accuracy - E1502A SCP (90-day)

Range ± FS	Linearity % of rdg	Offset error	Noise 3 sigma	Accuracy limits
.0625V	± .01%	7.2 µV	34 µV	± [.0001*rdg + 7.2 µV + 34/20 µV]
.25V	± .01%	12.2 µV	60 µV	± [.0001*rdg + 12.2 µV + 60/20 µV]
1.0V	± .01%	33 µV	110 µV	± [.0001*rdg + 33.0 µV + 110/20 µV]
4.0V	± .01%	122 µV	450 µV	± [.0001*rdg + 122.0 µV + 450/20 µV]
16.0V	± .01%	488 µV	1.8 mV	± [.0001*rdg + 488.0 µV + 1.8/20 mV]

Test Conditions:
 23°C ± 1°C with *CAL? done after a one-hour warm-up. CAL:ZERO? done within 5 minutes before the measurement. Autoranging OFF.
 Temperature coefficients: Gain - 10ppm/°C after *CAL?. Offset (0-30°C) no additional error, (30-40°C) 0.1 µV/°C, (40-55°C) 2.4 µV + 0.27 µV/°C.

Table A-3. DCV Accuracy - E1503A SCP @ Gain X1 (90-day)

Range ± FS	Linearity % of rdg	Offset Error				Noise 3 sigma
		2 Hz	10 Hz	100 Hz	Filter OFF	
.0625V	± .01%	13 µV	9.5 µV	6.8 µV	6.3 µV	45 µV
.25V	± .01%	15 µV	12.5 µV	11.2 µV	10.8 µV	63 µV
1.0V	± .01%	33 µV	31.8 µV	31.3 µV	31.2 µV	112 µV
4.0V	± .01%	123 µV	122 µV	122 µV	122 µV	450 µV
16.0V	± .01%	488 µV	488 µV	488 µV	488 µV	1.8 mV

Accuracy limits: ± [.0001*rdg + offset + noise/20]

Test Conditions:
 23°C ± 1°C with *CAL? done after a one-hour warm-up. CAL:ZERO? done within 5 minutes before the measurement. Autoranging OFF.
 Temperature coefficients: Gain - 15 ppm/°C after *CAL?. Offset - Add tempco + fixed offset to offset above.

Temp	Tempco	2 Hz	10 Hz	100 Hz	Filter OFF
0-30°C	0.16 µV/°C	0 µV	0 µV	0 µV	0 µV
30-40°C	0.18 µV/°C	13 µV	9 µV	1.1 µV	0.2 µV
40-55°C	0.39 µV/°C	31 µV	22 µV	6.4 µV	1.1 µV

Table A-4. DCV Accuracy - E1503A SCP @ Gain X8 (90-day)

Range ± FS	Linearity % of rdg	Offset Error				Noise 3 sigma
		2 Hz	10 Hz	100 Hz	Filter OFF	
.0078V	± .01%	4.6 µV	4.2 µV	3.8 µV	3.7 µV	5.8 µV
.031V	± .01%	4.8 µV	4.6 µV	4.4 µV	4.3 µV	6.9 µV
.125V	± .01%	6 µV	5.3 µV	5 µV	4.9 µV	14 µV
0.5V	± .01%	16 µV	16 µV	16 µV	16 µV	56 µV
2.0V	± .01%	61 µV	61 µV	61 µV	61 µV	225 µV

Accuracy limits: ± [.0001*rdg + offset + noise/20]

Test Conditions:
 23°C ± 1°C with *CAL? done after a one-hour warm-up. CAL:ZERO? done within 5 minutes before the measurement. Autoranging OFF.
 Temperature coefficients: Gain - 15 ppm/°C after *CAL?. Offset - Add tempco + fixed offset to offset above.

Temp	Tempco	2 Hz	10 Hz	100 Hz	Filter OFF
0-30°C	0.16 µV/°C	0 µV	0 µV	0 µV	0 µV
30-40°C	0.18 µV/°C	4.3 µV	2.7 µV	1.0 µV	0.2 µV
40-55°C	0.39 µV/°C	13 µV	10 µV	6.2 µV	0.8 µV

Table A-5. DCV Accuracy - E1503A SCP @ Gain X64 (90-day)

Range ± FS	Linearity % of rdg	Offset Error				Noise 3 sigma
		2 Hz	10 Hz	100 Hz	Filter OFF	
.0039V	± .01%	2.9 µV	2.3 µV	2.1 µV	2.1 µV	1.6 µV**
.0156V	± .01%	3 µV	2.4 µV	2.2 µV	2.2 µV	2.2 µV
.0625V	± .01%	3.5 µV	3 µV	2.9 µV	2.9 µV	7 µV
.25V	± .01%	8.2 µV	8 µV	8 µV	8 µV	28 µV

Accuracy limits: ± [.0001*rdg + offset + noise/20]

Test Conditions:
 23°C ± 1°C with *CAL? done after a one-hour warm-up. CAL:ZERO? done within 5 minutes before the measurement. Autoranging OFF.
 Temperature coefficients: Gain - 15 ppm/°C after *CAL?. Offset - Add tempco + fixed offset to offset above.

Temp	Tempco	2 Hz	10 Hz	100 Hz	Filter OFF
0-30 °C	0.16 µV/°C	0 µV	0 µV	0 µV	0 µV
30-40°C	0.18 µV/°C	1.1µV	0.2 µV	0.1 µV	0.1 µV
40-55°C	0.39 µV/°C	6 µV	1.4 µV	0.6 µV	0.6 µV

**
1.9 µV for 100 Hz filter.

Table A-6. Excitation Voltage Accuracy - E1506A/E1507A SCPs (90-day)

Nominal Value	Accuracy limits
3.9000 Vdc	± 512 µV
Test Conditions:	
- 23°C ± 1°C with *CAL? done after a one-hour warm-up. - CAL:ZERO? done within 5 minutes before the measurement. - Temperature coefficient: 39 µV/°C.	

Table A-7. DCV Accuracy - E1508A SCP (90-day)

Range ± FS	Linearity % of rdg	Offset error	Noise 3 sigma	Accuracy limits
.0039V	± .01%	3.8 µV	3.4 µV	± [.0001*rdg + 3.8 µV + 3.4/20 µV]
.0156V	± .01%	4.2 µV	4.4 µV	± [.0001*rdg + 4.2 µV + 4.4/20 µV]
.0625V	± .01%	4.9 µV	7.5 µV	± [.0001*rdg + 4.9 µV + 7.5/20 µV]
0.25V	± .01%	8.0 µV	28 µV	± [.0001*rdg + 8.0 µV + 28/20 µV]
1.0V	± .01%	31.0 µV	113 µV	± [.0001*rdg + 31 µV + 113/20 µV]
Test Conditions:				
23°C ± 1°C with *CAL? done after a one-hour warm-up. CAL:ZERO? done within 5 minutes before the measurement. Autoranging OFF. Temperature coefficients: Gain - 15 ppm/°C after *CAL?. Offset (0-30°C) 0.16 µV/°C, (30-40°C) 0.18 µV/°C, (40-55°C) 0.39 µV/°C.				

Table A-8. DCV Accuracy - E1509A SCP (90-day)

Range ± FS	Linearity % of rdg	Offset error	Noise 3 sigma	Accuracy limits
.0039V	± .01%	2.3 µV	1.7 µV	± [.0001*rdg + 2.3 µV + 1.7/20 µV]
.0156V	± .01%	2.4 µV	2.5 µV	± [.0001*rdg + 2.4 µV + 2.5/20 µV]
.0625V	± .01%	3.0 µV	7.0 µV	± [.0001*rdg + 3.0 µV + 7.0/20 µV]
.25V	± .01%	8.0 µV	28 µV	± [.0001*rdg + 8.0 µV + 28/20 µV]
Test Conditions:				
23°C ± 1°C with *CAL? done after a one-hour warm-up. CAL:ZERO? done within 5 minutes before the measurement. Autoranging OFF. Temperature coefficients: Gain - 15 ppm/°C after *CAL?. Offset (0-30°C) 0.16 µV/°C, (30-40°C) 0.18 µV/°C, (40-55°C) 0.39 µV/°C.				

Table A-9. DCV Accuracy - E1510A and E1511A SCPs @ Gain X0.5 (90-day)

Range ± FS	Linearity % of rdg	Offset error	Noise 3 sigma	Accuracy limits
.125V	± .02%	488 µV	1.5 mV	± [.0002*rdg + 488 µV + 1.5/20 mV]
0.5V	± .02%	488 µV	1.5 mV	± [.0002*rdg + 488 µV + 1.5/20 mV]
2V	± .02%	488 µV	1.5 mV	± [.0002*rdg + 488 µV + 1.5/20 mV]
8V	± .02%	488 µV	1.5 mV	± [.0002*rdg + 488 µV + 1.5/20 mV]

Test Conditions:
 23°C ± 1°C with *CAL? done after a one-hour warm-up. CAL:ZERO? done within 5 minutes before the measurement.
 Autoranging OFF.
 Temperature coefficients: Gain - 10 ppm/°C after *CAL?. Offset (0-30°C)
 0 µV/°C, (30-55°C) 0.75 µV/°C.

Table A-10. DCV Accuracy - E1510A and E1511A SCPs @ Gain X8 (90-day)

Range ± FS	Linearity % of rdg	Offset error	Noise 3 sigma	Accuracy limits
7.8 mV	± .02%	30.5 µV	95 µV	± [.0002*rdg + 30.5 µV + 95 µV]
31.25 mV	± .02%	30.5 µV	95 µV	± [.0002*rdg + 30.5 µV + 95 µV]
125 mV	± .02%	30.5 µV	95 µV	± [.0002*rdg + 30.5 µV + 95 µV]
0.5 V	± .02%	30.5 µV	95 µV	± [.0002*rdg + 30.5 µV + 95 µV]

Test Conditions:
 23°C ± 1°C with *CAL? done after a one-hour warm-up. CAL:ZERO? done within 5 minutes before the measurement.
 Autoranging OFF.
 Temperature coefficients: Gain - 10 ppm/°C after *CAL?. Offset (0-30°C)
 0 µV/°C, (30-55°C) 0.75 µV/°C.

Table A-11. DCV Accuracy - E1510A and E1511A SCPs @ Gain X64 (90-day)

Range ± FS	Linearity % of rdg	Offset error	Noise 3 sigma	Accuracy limits
3.9 mV	± .02%	15.0 µV	12 µV	± [.0002*rdg + 15.0 µV + 12/20 µV]
15.6 mV	± .02%	15.0 µV	12 µV	± [.0002*rdg + 15.0 µV + 12/20 µV]
62.5 mV	± .02%	15.0 µV	12 µV	± [.0002*rdg + 15.0 µV + 12/20 µV]

Test Conditions:
 23°C ± 1°C with *CAL? done after a one-hour warm-up. CAL:ZERO? done within 5 minutes before the measurement.
 Autoranging OFF.
 Temperature coefficients: Gain - 10 ppm/°C after *CAL?. Offset (0-40°C)
 0.14 µV/°C, (40-55°C) 0.38 µV/°C.

Table A-12. DCV Accuracy - E1510A and E1511A SCPs @ Gain X512 (90-day)

Range ± FS	Linearity % of rdg	Offset error	Noise 3 sigma	Accuracy limits
7.81 mV	± .04%	15.0 µV	2 µV	± [.0002*rdg + 15.0 µV + 2/20 µV]
Test Conditions:				
23°C ± 1°C with *CAL? done after a one-hour warm-up. CAL:ZERO? done within 5 minutes before the measurement. Autoranging OFF. Temperature coefficients: Gain - 10 ppm/°C after *CAL?. Offset (0-40°C) 0.14 µV/°C, (40-55°C) 0.38 µV/°C.				

Table A-13. DCV Accuracy - E1510A SCP Straight Through Channels (90-day)

Range ± FS	Linearity % of rdg	Offset error	Noise 3 sigma	Accuracy limits
.0625V	± .01%	5.3 µV	18 µV	± [.0001*rdg + 5.3 µV + 18/20 µV]
.25V	± .01%	10.3 µV	45 µV	± [.0001*rdg + 10.3 µV + 45/20 µV]
1.0V	± .01%	31 µV	110 µV	± [.0001*rdg + 31 µV + 110/20 µV]
4.0V	± .01%	122 µV	450 µV	± [.0001*rdg + 122 µV + 450/20 µV]
16.0V	± .01%	488 µV	1.8 mV	± [.0001*rdg + 488 µV + 1.8/20 mV]
Test Conditions:				
23°C ± 1°C with *CAL? done after a one-hour warm-up. CAL:ZERO? done within 5 minutes before the measurement. Autoranging OFF. Temperature coefficients: Gain - 10ppm/°C after *CAL?. (0-40°C) 0.14 µV/°C, (40-55°C) 0.8 µV + 0.38 µV/°C.				

Table A-14. DCV Accuracy - E1512A SCP (90-day)

Range ± FS	Linearity % of rdg	Offset error	Noise 3 sigma	Accuracy limits
.0625V	± .01%	7.2 µV	34 µV	± [.0001*rdg + 7.2 µV + 34/20 µV]
.25V	± .01%	12.2 µV	60 µV	± [.0001*rdg + 12.2 µV + 60/20 µV]
1.0V	± .01%	33 µV	110 µV	± [.0001*rdg + 33.0 µV + 110/20 µV]
4.0V	± .01%	122 µV	450 µV	± [.0001*rdg + 122.0 µV + 450/20 µV]
16.0V	± .01%	488 µV	1.8 mV	± [.0001*rdg + 488.0 µV + 1.8/20 mV]
Test Conditions:				
23°C ± 1°C with *CAL? done after a one-hour warm-up. CAL:ZERO? done within 5 minutes before the measurement. Autoranging OFF. Temperature coefficients: Gain - 10ppm/°C after *CAL?. Offset (0-30°C) no additional error, (30-40°C) 0.1 µV/°C, (40-55°C) 2.4 µV + 0.27 µV/°C.				

Table A-15. DCV Accuracy - E1513A SCP (90-day)

Range ± FS	Linearity % of rdg	Offset error	Noise 3 sigma	Accuracy limits
1.0V 4.0V	± .02% ± .02%	500 µV 1.95 mV	1.8 mV 7.0 mV	± [.0002*rdg + 500 µV + 1.8/20 mV] ± [.0002*rdg + 1.95 mV + 7/20 mV]
Test Conditions:				
23°C ± 1°C with *CAL? done after a one-hour warm-up. CAL:ZERO? done within 5 minutes before the measurement. Autoranging OFF. Temperature coefficients: Gain - .001/°C after *CAL?. Offset (0-40°C) 0.14 µV/°C, (40-55°C) 0.8 µV + 0.38 µV/°C.				

Table A-16. DCV Accuracy - E1514A and E1515A SCPs (90-day)

Range ± FS	Linearity % of rdg	Offset error	Noise 3 sigma	Accuracy limits
16 V	± .015%	976 µV	2.1 mV	± [.00015*rdg + 976 µV + 2.1/20 mV]
Test Conditions:				
23°C ± 1°C with *CAL? done after a one-hour warm-up. CAL:ZERO? done within 5 minutes before the measurement. Autoranging OFF. Temperature coefficients: Gain - 10ppm/°C after *CAL?. Offset (0-40°C) 0.14 µV/°C, (40-55°C) 0.8 µV/°C				

Table A-17. DCV Accuracy - E1516A and E1517A SCPs (90-day)

E1516A SCP				
Range ± FS	Linearity % of rdg	Offset error	Noise 3 sigma	Accuracy limits
.0625 V	± .015%	3.8 µV	10 µV	± [.00015*rdg + 3.8 µV + 10/20 µV]
Test Conditions:				
23°C ± 1°C with *CAL? done after a one-hour warm-up. CAL:ZERO? done within 5 minutes before the measurement. Autoranging OFF. Temperature coefficients: Gain - 10ppm/°C after *CAL?. Offset (0-40°C) 0.14 µV/°C, (40-55°C) 0.8 µV/°C				
E1517A SCP				
Range ± FS	Linearity % of rdg	Offset error	Noise 3 sigma	Accuracy limits
.0625 V	± .015%	3.8 µV	12.5 µV	± [.00015*rdg + 3.8 µV + 12.5/20 µV]
Test Conditions:				
23°C ± 1°C with *CAL? done after a one-hour warm-up. CAL:ZERO? done within 5 minutes before the measurement. Autoranging OFF. Temperature coefficients: Gain - 10ppm/°C after *CAL?. Offset (0-40°C) 0.14 µV/°C, (40-55°C) 0.8 µV/°C				

Table A-18. DCV Accuracy - E1518A SCP (90-day)

Range ± FS	Linearity % of rdg	Offset error	Noise 3 sigma	Accuracy limits
.0039 V	± .01%	3.8 µV	3.4 µV	± [.0001*rdg + 3.8 µV + 3.4/20 µV]
.0156 V	± .01%	4.2 µV	4.4 µV	± [.0001*rdg + 4.2 µV + 4.4/20 µV]
.0625 V	± .01%	4.9 µV	7.5 µV	± [.0001*rdg + 4.9 µV + 7.5/20 µV]
.25 V	± .01%	8.0 µV	28 µV	± [.0001*rdg + 8.0 µV + 28/20 µV]
1.0 V	± .01%	31.0 µV	113 µV	± [.0001*rdg + 31. µV + 113/20 µV]

Test Conditions:
 23°C ± 1°C with *CAL? done after a one-hour warm-up. CAL:ZERO? done within 5 minutes before the measurement.
 Autoranging OFF.
 Temperature coefficients: Gain - 15ppm/°C after *CAL?. Offset (0-30°C) 0.16 µV/°C, (30-40°C) 0.18 µV/°C, (40-55°C) 0.39 µV/°C.

Table A-19. DCV Source Accuracy - E1531A and E1537A SCPs (90-day)

Voltage Amplitude	Voltage Output Accuracy	Offset	Noise 3 sigma
± 16V Full Scale at up to 5 mA	± .02%	3.6 mV	<1.2 mV rms (20 Hz - 250 kHz)

Accuracy limits: ± [.0002*Vout + offset + noise]

Test Conditions:
 - 23°C ± 1°C with *CAL? done after a one-hour warm-up and applied load is ≥100 KΩ.
 - CAL:ZERO? done within 5 minutes before the measurement.

DCI Accuracy Equations

Table A-20 shows DC current accuracy limits for the E1505A and E1518A SCPs. Table A-21 shows DC current accuracy limits for the E1532A SCP. DC current specifications are defined for 90 days @ 23°C ± 1°C.

Table A-20. DCI Accuracy - E1505A and E1518A SCPs (90-day)

Current Amplitude	Output Accuracy	Ripple & Noise 3 sigma
30.518 µA	± 9 nA	± 9 nA
488.28 µA	± 60 nA	± 15 nA

Accuracy limits: ± [Iout + offset + noise]

Test Conditions:
 - 23°C ± 1°C with *CAL? done after a one-hour warm-up.
 - CAL:ZERO? done within 5 minutes before the measurement.

Table A-21. DCI Accuracy - E1532A SCP (90-day)

Current Amplitude	Output Accuracy	Offset	Noise 3 sigma
-9.5 mA	± .06%	3.3 µA	<2 µArms
-5.0 mA	± .06%	3.3 µA	<2 µArms
5.0 mA	± .06%	3.3 µA	<2 µArms
9.5 mA	± .06%	3.3 µA	<2 µArms

Accuracy limits: ± [lout + offset + noise]

Test Conditions:

- 23°C ± 1°C with *CAL? done after a one-hour warm-up and applied load is ≤500Ω.
- CAL:ZERO? done within 5 minutes before the measurement.

Frequency, Pulse and Pulse Width Accuracy Equations

Table A-22 shows frequency counter, frequency source and pulse source accuracy limits for the E1534A SCP. Table A-23 shows frequency counter, frequency source, pulse source and pulse width measurement accuracy limits for the E1538A SCP. Specifications are defined for 90 days @ 23°C ± 1°C.

Table A-22. Frequency, Pulse and Pulse Source Accuracy - E1534A SCP (90-day)

FREQUENCY COUNTER		
Range	Accuracy	Resolution
$\frac{1}{t_{aperture}}$ to 100 KHz	± 0.1%	$\frac{f_{input}}{t_{aperture} \times 4.194MHz}$
FREQUENCY SOURCE		
Range	Accuracy	Resolution
Square wave: 64 Hz TO 40 kHz Other shapes: 128 Hz to 40 kHz	± 0.1%	$\frac{(fout)^2}{4.194MHz}$
PULSE SOURCE		
Range	Accuracy	Resolution
Square wave: 7.87 µsec to 1/f-7.87 µsec Pulse per trigger: 7.87 µsec to 7.812 msec	± (0.1% + 200 nsec)	238.4 nsec
Test Conditions: - 23°C ± 1°C with *CAL? done after a one-hour warm-up.		

**Table A-23. Frequency, Pulse and Pulse Source Accuracy - E1538A SCP
(90-day)**

FREQUENCY COUNTER		
Range	Accuracy	Resolution
$\frac{1}{t_{aperture}}$ to 100 KHz	± 0.01%	$\frac{f_{input}}{t_{aperture}} \times 4.194MHz$
FREQUENCY SOURCE		
Range	Accuracy	Resolution
Square wave: 64 Hz TO 40 kHz Other shapes: 128 Hz to 40 kHz	± 0.01%	$\frac{(fout)^2}{4.194MHz}$
PULSE SOURCE		
Range	Accuracy	Resolution
Square wave: 7.87 µsec to 1/f-7.87 µsec Pulse per trigger: 7.87 µsec to 7.812 msec	± (0.01% + 200 nsec)	238.4 nsec
PULSE WIDTH MEASURE (must have VRS switches OFF)		
Range	Accuracy	Resolution
1.5 µsec to 1 sec periods averaged: 1 to 255	± (0.1% + 100 nsec)	59.6 nsec
Test Conditions: - 23°C ± 1°C with *CAL? done after a one-hour warm-up.		

Measurement Uncertainty Calculations

This section shows how measurement uncertainties are calculated for the Datron 4708 Source and the HP 3458A DMM. The Datron 4708 source is used for DCV inputs for the performance verification tests.

The HP 3458A DMM is used to measure the DC current output for E1505A and E1518A SCP tests and to measure the excitation voltage value for the E1506A and E1507A SCP tests. Assumed test conditions for both instruments are:

- Temperature of 23°C ± 1°C
- 90 days since calibration
- At least one hour warm-up time

DC Source Measurement Uncertainty

Measurement uncertainties for the Datron 4708 source are calculated using the 90-day accuracy specifications in the *Datron 4708 User's Handbook*. Measurement Uncertainty = Datron Accuracy + Calibration Uncertainty, where Datron Accuracy (ppm) = Accuracy Relative to Calibration Standards = ± (ppm OUTPUT + ppm FS) and FS = 2 x range for all ranges.

From *Section 6 - Specifications* of the *Datron 4708 User's Handbook*, DC Voltage (Option 10) Measurement Accuracy follows, where Datron Accuracy = ± (ppm OUTPUT + ppm FS).

Table A-24. Datron 4708 DC Voltage Specifications (Option 10, 90-day)

Datron Range (Volts)	Datron Accuracy (ppm)	Calibration Uncertainty (ppm)	Total Measurement Uncertainty (µV)
100.00000 mV	3 + 0.4 µV	4	± [7.0 * OUTPUT + 0.4]
1.0000000 V	2 + 0.4	2	± [4.0 * OUTPUT + 0.8]
10.000000 V	1 + 0.15	1.5	± [2.5 * OUTPUT + 3.0]
100.00000 V	2 + 0.25	2	± [4.0 * OUTPUT + 50.0]

For example, for a 3.2 Vdc OUTPUT and 10.000000 V range the Measurement Uncertainty (µV) = ± [(1.0 x 3.2) + (2 x 0.15 x 10) + (1.5 x 3.2)] = ± 11 µV = ± 1.1E-5 V. Or, from Table A-20, Measurement Uncertainty (µV) = ± [(2.5 x 3.2) + 3.0] = ± 11 µV = ± 1.1E-5 V.

DMM Measurement Uncertainty

The HP 3458A DMM is used to measure the current output from the E1505A, E1518A and E1532A SCPs, to measure the excitation voltage for the E1506A and E1507A Strain Gage SCPs and to measure the voltage output for the E1531A and E1537A SCPs. Table A-25 shows measurement uncertainty for the DCV and DCI ranges used for these SCPs. All accuracy readings are for PRESET;NPLC 100.

DMM Accuracy = ppm of Reading + ppm of Range

Table A-25. HP 3458A DMM DCV/DCI Accuracy (90-day)

SCP	SCP Output	DMM Range	DMM Accuracy	Measurement Uncertainty
E1505A/E1518A	30.518 μ A	100 μ A	15 + 8	1.26E-3 μ A
E1505A/E1518A	488.28 μ A	1 mA	15 + 5	12.3E-3 μ A
E1532A	-9.5 mA	10 mA	15 + 5	1.93E-4 mA
E1532A	-5 mA	10 mA	15 + 5	1.25E-4 mA
E1532A	0 mA	10 mA	15 + 5	5.00E-5 mA
E1532A	5 mA	10 mA	15 + 5	1.25E-4 mA
E1532A	9.5 mA	10 mA	15 + 5	1.93E-4 mA
E1506A/E1507A	3.9 Vdc	10 Vdc	4.1 + 0.05	1.65E-5 Vdc
E1531A/E1537A	-15.5 Vdc	100 Vdc	6.0 + 0.30	1.23E-4 Vdc
E1531A/E1537A	-5 Vdc	10 Vdc	4.1 + 0.05	2.10E-5 Vdc
E1531A/E1537A	0 Vdc	10 Vdc	4.1 + 0.05	5.00E-7 Vdc
E1531A/E1537A	5 Vdc	10 Vdc	4.1 + 0.05	2.10E-5 Vdc
E1531A/E1537A	15.5 Vdc	100 Vdc	6.0 + 0.30	1.23E-4 Vdc

For example, for an E1505A SCP and the 30.518 μ A range, DCI measurement uncertainty = $\pm [(15 \times 10^{-6} \times 30.518 \times 10^{-6}) + (8 \times 10^{-6} \times 100 \times 10^{-6})] = \pm 1.26 \times 10^{-9} \text{ A} = \pm 1.26 \times 10^{-3} \mu\text{A}$. Or, for an E1506A SCP with 3.9000 Vdc excitation voltage, DCV measurement uncertainty = $\pm (4.1 \times 10^{-6} \times 3.9 + 0.05 \times 10^{-6} \times 10) = \pm 1.65 \times 10^{-5} \text{ Vdc}$.

AC Signal Source Uncertainty

The HP 3325A Synthesizer/Function Generator is used to source the square wave signal input for the E1534A and E1538A SCPs. This signal is used to check the frequency counting function of both SCPs as well as the pulse width measurement function and VRS input circuit verification of the E1538A.

Frequency accuracy of the HP 3325A is $\pm 5 \times 10^{-6}$ of the output signal frequency.

Counter/Totalizer Pulse Width Measurement Uncertainty

The HP E1332A Counter/Totalizer is used to measure the pulse width output from the E1534A and E1538A SCPs. These calculations assume an external 500Ω pull-up resistor from the High terminal to an external +5V supply. Without this, the rise-time is much slower increasing the trigger noise error. The TAR is approximately 1:1 for pulse widths of 10 μS - 500 μS because the E1332A has a resolution of 200 nS (0.2 μS). This resolution error is the majority of the E1534A and E1538A pulse width specification for microsecond pulse widths. Table A-26 shows measurement uncertainty for pulse width measurements.

Table A-26.

Pulse Width	Resolution	Timebase Error	Trigger Noise Error	Measurement Uncertainty
1 mS	200 nS	2 μS	$\frac{\sqrt{(200\mu V^2) + (E_v)^2}}{\pm}$	
10 μS - 500 μS	200 nS	2 μS		

Test Accuracy Ratio (TAR) Calculations

For the HP E1415A or HP E1419A, DCV Test Accuracy Ratio (TAR) is:

$$TAR = \frac{\textit{Maximum} - \textit{Input}}{\textit{Measurement Uncertainty}}$$

where Maximum, Input, and Measurement Uncertainty are all in Vdc.

For example, for a +3.2 Vdc measurement (input to the 4V range) of an E1501A SCP, maximum value = 3.2005 Vdc and Datron 4708 Measurement Uncertainty = 1.1E-5 Vdc, the TAR is calculated as follows:

$$TAR = \frac{3.2005 - 3.2000}{1.1 \times 10^{-5}} = 45.45$$

Since this value is >10:1, the entry in Table 2-1 "*HP E1415A/E1419A Performance Test Record*" is ">10:1".

Appendix B

Error Messages

This appendix contains both the Self Test Error Messages (Table B-1) and the general error messages (Table B-2). Self Test error messages are those errors that result from a failed Self Test. General error messages are those errors that result from programming errors, calibration errors, etc.

Self Test Error Messages

During the first five minutes after power is applied, *TST? may fail. Allow the module to warm up before executing *TST?.

If the self test error code number is between 100 and 163, subtract 100 to find the failed channel. If the error number is between 200 and 204, subtract 200 to find the A/D range (0 to 4) that failed.

Table B-1. HP E1415A and HP E1419A Self Test Error Messages

Self Test Error Code	Description
1	Digital Failure. Writes and reads patterns to register via A16.
2	Digital Failure. Writes and reads patterns to register via A16 and A24.
3	Digital Failure. Writes and reads patterns to register via A16 and A24.
4	Digital Failure. Writes data to FIFO and CVT through A24. Reads data from FIFO via A16, reads data from CVT via A24.
5	Digital Failure. DSP sends count to FIFO. Reads count from FIFO via A16.
6	Digital Failure. Checks operation of Measurement Complete status bit by toggling initiated line in scan status register.
7	Digital Failure. Checks operation of FIFO half and FIFO full IRQ generation. Note: This test will fail on models with serial number 100 and lower.
8	Digital Failure. Checks trigger operation by using trigger timer and trigger count.
9	Digital Failure. Checks operation of trigger sources.
20	SCP's and MUX. An SCP had an ID of 0000h. Only first channel of SCP is listed next.
30	MUX & A/D. Digital Readback of shift registers U4501 and U4504.
31	MUX & A/D. Digital Readback of shift registers U4506 and U4508.
32	MUX & A/D. Digital Readback of shift registers U4600 and U4602.
33	MUX & A/D. Checks SAFEn Monostable (U4507).
34	MUX & A/D. Digital Readback of Hi-speed MUX control FA0. Checks A/D (U3535), ROM (U3536).
35	MUX & A/D. Digital Readback of Hi-speed MUX control FA1. Checks A/D (U3535), ROM (U3536).
36	MUX & A/D. Digital Readback of Hi-speed MUX control FA2 & FA3. Checks A/D (U3535), ROM (U3536).
37	MUX & A/D. Digital Readback of Hi-speed MUX control FA4 & FA5. Checks A/D (U3535), ROM (U3536).
40	A/D. Checks 4.5 Vref > 4.35V at SelfTestMux U3135. U3135 or U3128 may have large leakage current.

Table B-1. HP E1415A and HP E1419A Self Test Error Messages

Self Test Error Code	Description
41	A/D. Puts 0.25 V from Cal_src R1 to SelfTestMux U3135. Should read between 0.2 and 0.3 V but reads between 2 to 2.5 V. Checks Ref. Divider RP3101.
42	A/D. Puts 0.25 V from Cal_src R1 to SelfTestMux U3135. Should read between 0.2 and 0.3 V but reads between -4.5 to 0.2, 0.3 to 2.0, or 2.5 to 4.5 V.
43	A/D. TST_RD at the input to the A/D SelfTestMux U3135 is not within ± 0.1 V with all Relay drives off.
44	A/D. CAL_SRC at the input to the A/D SelfTestMux U3135 is not within ± 0.1 V with the CAL SOURCE DAC centered on R1 or within $\pm .05$ V with the CAL SOURCE DAC centered on R0.
45	A/D. OFS_ADJ at the input to the A/D SelfTestMux U3135 is not within ± 0.02 V with the FINE OFST ADJUST dac code = 0.
46	A/D. OFS_ADJ at the input to the A/D SelfTestMux U3135 is not within -4.5 ± 0.1 V with the FINE OFST ADJUST dac code = 3685.
47	A/D. Problems with the COARSE OFST ADJUST DAC U3331. With input amp shorted, it could not zero out the offset. It could not adjust the offset by the following percent of ranges (Ex: $\pm 24\%$ of 1V for R2) R0: 79%, R1: 35%, R2: 24%, R3: 21%, R4: 20%.
48	A/D. With the input amp shorted and the COARSE OFST ADJUST DAC zeroed, could not zero out the offset and/or converge with the FINE OFST ADJUST DAC.
49	A/D. CHK ± 15 V at the input to the A/D SelfTestMux U3135 is within -0.4 V to -3.2 V. Check ± 15 V supplies ± 15 V $\pm 5\%$.
50	A/D. CAL_SRC R0 at the input to the A/D SelfTestMux U3135 is not within ± 0.35 V $\pm 5\%$ with ± 0.35 V output from CAL_SRC.
51	A/D. CAL_SRC R1 at the input to the A/D SelfTestMux U3135 is not within ± 14 V $\pm 5\%$ with ± 14 V output from CAL_SRC.
52	A/D. CAL_SRC R0 through the normal measurement path is not within ± 0.35 V $\pm 5\%$ with ± 0.35 V output from CAL_SRC.
53	A/D. CAL_SRC R1 through the normal measurement path is not within ± 15 V $\pm 5\%$ with ± 15 V output from CAL_SRC.
54	A/D. Rough check of the Gain Cal Dac. GCAL_OUT at the input to the A/D SelfTestMux U3135. The input amp input is at $\pm 85\%$ of FS. The limit varies from 15% on R0 to 3% on R4.
55	A/D. Tight err check on Gain Cal Dac. Uses normal measurement path. With -90% of full scale input, sets gain dac to 0, 2048, & 4095. Checks change between mid and extremes is 3.9% to 4.4% on all ranges.
56	A/D. Checks A/D autoranges correctly. Applies input of $\pm 90\% \pm 7\%$ of FS and checks range A/D took reading on. The reference voltages for the autorange circuitry are the ± 15 V supplies. Verify the ± 15 V supplies are ± 15.1 V $\pm 5\%$
57	A/D. Checks reading returned by A/D autorange is correct. Applies input of $\pm 90\% \pm 7\%$ of FS and checks reading returned is $\pm 10\%$ of input.
58	A/D. Checks Isource OFF ≤ 10 nA. With Isource on & I dac @ 2048, checks Isource 122.1 μ A $\pm 1.5\%$.
59	A/D. Checks range of the I dac. Changes I dac from 2048 to 0 and 4095, checks Isource changes from 1.8% to 1.96%.
60	A/D. Checks front end & A/D noise with A/D filter ON. The limits are 1.7CTSms R0 and 1.2CTSms R1 to R4.
61	A/D. Checks front end & A/D noise with A/D filter OFF. The limits are 2.7CTSrms R0 and 1.5CTSrms R1 to R4.
62	A/D. Checks offset between A/D filter ON and OFF. The limits in CTS are R0: 2.5, R1: 1.5, R2 to R4:1.
64	MUX. Zeroing of coarse and/or fine offset dacs failed before starting to test MUXs.
65	MUX. Could not verify Isource relay Open or Calbus positioned to SCP's with Isource.
66	MUX. Coil voltage on CAL_BUS relay is incorrect when positioning relay.

Table B-1. HP E1415A and HP E1419A Self Test Error Messages

Self Test Error Code	Description
67	MUX. Could not reposition CAL_BUS relay contacts.
68	MUX. Coil voltage on Isource relay is incorrect when positioning relay.
69	MUX. Could not reposition Isource relay contacts.
70	MUX. Coil voltage on OHM relay is incorrect when positioning relay.
71	MUX and A/D. Checks timing of SAFEn MONOSTABLE U4507.
72	MUX. Could not reposition one or more channel relay contacts. Blows relays open with SAFEn and verifies one bank & I & CALBUS relays open. Also checks the continuity through the SCPs. Make sure SCPs are completely seated. Swap and/or move SCPs and see if channel failures follow the moved SCP. With Strain completion and I source cards, uses SCP sources and Rs.
73	MUX. Coil voltage on channel relay coils is incorrect when positioning bank relays. Although all 8 relays in a bank have the same voltage, only the first relay in bank is listed.
74	MUX. Open transducer detect for a channel does not work correctly. The A/D senses the current through the 7.5k Ohm resistor. Either the total offset voltage is too large with OTD on or the difference between OTD on and off is too small. The limits for this test change with SCP types. Swap and/or move SCPs and see if channel failures follow the moved SCP.
75	MUX. There was excessive current leakage for a channel. OTD is OFF. The A/D senses the current through the 7.5k Ohm. The limits for this test change with different SCP types. Swap and/or remove SCPs and see if the channel failures follow the moved SCP.
76	MUX. There was excessive voltage offset for a channel. OTD if OFF. The limits for this test change with different SCP types. Swap and/or remove SCPs and see if the channel failures follow the moved SCP.
80	MUX. The mid-scale Strain dac output is incorrect for a channel. Error only reported for 1st channel of SCP. Only tested on E1506A and E1507A. Swap and/or move SCPs and see if channel failure follows the moved SCP.
81	MUX. The range of the Strain E dac is incorrect for a channel. Error only reported for the 1st channel of the SCP. Only tested on E1506A & E1507A. Swap and/or move SCPs and see if channel failure follows the moved SCP.
82	MUX. The noise of the Strain E dac is high for a channel. Error only reported for 1st channel of SCP. Only tested on E1506A & E1507A. Swap and/or move SCPs and see if channel failure follows the moved SCP.
83	MUX. With S_CAL? open, the R_leg resistance was incorrect for a channel. Different specs with dip switch open and shut. Tests only STRAIN channels 0, 2, 4, & 6 of SCP. Only tested on E1506A & E1507A. Swap and/or move SCPs and see if channel failure follows the moved SCP.
84	MUX. When closing the S_CAL switch, the resistance change was incorrect. Different specs with dip switch open and shut. Tests only STRAIN channels 0, 2, 4, & 6 of SCP. Only tested on E1506A & E1507A. Swap and/or move SCPs and see if channel failure follows the moved SCP.
86	MUX. Checks SCP Isource OFF <= 10 nA. Checks both SCP Isource ranges. Only tested on E1505A. Swap and/or move SCPs and see if channel failure follows the moved SCP.
87	MUX. Checks SCP Isource dac mid-scale. Checks both SCP Isource ranges. Only tested on E1505A. Swap and/or move SCPs and see if channel failure follows the moved SCP.
88	MUX. Checks SCP Isource dac range. Checks both SCP Isource ranges. Only tested on E1505A. Swap and/or move SCPs and see if channel failure follows the moved SCP.
89	MUX. Checks SCP Isource compliance > 10V. Checks both SCP Isource ranges. Only tested on E1505A. Swap and/or move SCPs and see if channel failure follows the moved SCP.
90	MUX. Checks Strain Gage SCP Wagner voltage control. Sets excitation voltage to 5 volts. Makes a measurement with the Wagner voltage off, then on. The difference between the two is checked for the expected change. Only tested on E1510A and E1511A. Swap and/or move SCPs and see if channel failure follows the moved SCP.

Table B-1. HP E1415A and HP E1419A Self Test Error Messages

Self Test Error Code	Description
91	MUX. Checks the range of operation of the autobalance DAC with the input shorted. The DAC is set to minimum, center, and maximum. The change in results is checked against expected changes. Only tested on E1510A and E1511A. Swap and/or move SCPs and see if channel failure follows the moved SCP.
92	MUX. The sample/hold channels are checked to see that they indeed do hold a value even though the input is changed. The internal short is sampled and held, then OTD is turned on changing the input. The results are checked to see that they are not affected by the input change over a long period. Only tested on E1510A and E1511A. Swap and/or move SCPs and see if channel failure follows the moved SCP.
93	MUX. The sample/hold channels are checked to see that the droop of the held value is within tolerance. The cal source set at 4V is sampled and held. Measurements are checked over a long period to verify that droop is within tolerance. Only tested on E1510A and E1511A. Swap and/or move SCPs and see if channel failure follows the moved SCP.
301	MUX. Checking digital readback on the output DACs. : Tested on E1531s & E1532s. : Swap and/or move SCPs and see if failures follow the moved SCP.
302	MUX. Checking noise on the output DACs. : Tested at $\pm 15V$ across the 7.5k Cal resistor : Spec is 1.5mVrms on the E1531, 200nArms on E1532. : The A/D input amplifier (DG509s) can cause this failure. : Tested on E1531s & E1532s. : Swap and/or move SCPs and see if failures follow the moved SCP.
303	MUX. Checking output error on the current output DACs. : Spec is 15uA at 0 current, 60uA at ± 2 mA. : Measured across the 7.5k Cal Resistor. : Tested on E1532s. : Swap and/or move SCPs and see if failures follow the moved SCP.
304	MUX. Checking output resistance of the current output DACs. : This is the ONLY test that tests Input Amplifier Common Mode Offset (and noise). : Senses current across 69 Ohm resistor (R*40) on SCP while switching output from 7.5k Ohms to short. : The A/D input amplifier (DG509s) can cause this failure. Check A/D amp 0.25V range for noise or offset when shorted with \pm Volts common mode applied. : Tested on E1532s. E1415s/E1315s [NOT SCP] can also cause this failure. : Spec is 30uA (15V/30uA=500k Ohms). : Swap and/or move SCPs and see if failures follow the moved SCP. : If multiple channels have this failure, suspect motherboard. Even a single channel failure may be a motherboard problem, not SCP problem.
305	MUX. Checking output error on the current output DACs. : Tests Input Amplifier linearity more accurately than A/D Linearity Test 55. : Spec is 15uA at 0 current, 60uA at ± 2 mA, 100uA at ± 10.35 mA output. : Measured across the 69 Ohm resistor (R*40) on SCP. : Tested on E1532s. Also tests E1415/E1315 linearity. : Swap and/or move SCPs and see if failures follow the moved SCP. : If multiple channels have this failure, suspect motherboard.
306	MUX. Checking linearity of the current output DACs. : Tests Input Amplifier linearity more accurately than A/D Linearity Test 55. : Checks that the gain at -2mA & ± 10.35 mA is within 0.3% of the gain at 2mA. : Measured across the 69 Ohm resistor (R*40) on SCP. : Tested on E1532s. Also tests E1415/E1315 linearity. : Swap and/or move SCPs and see if failures follow the moved SCP. : If multiple channels have this failure, suspect motherboard.

Table B-1. HP E1415A and HP E1419A Self Test Error Messages

Self Test Error Code	Description
307	<p>MUX. Checking linearity of the current output DACs.</p> <ul style="list-style-type: none"> : Tests Input Amplifier linearity more accurately than A/D Linearity Test 55. : Checks that the gain at -2mA is within 0.3% of the gain at 2mA. : Measured across the 7.5k Ohm cal resistor. : Tested on E1532s. Also tests E1415/E1315 linearity. : Swap and/or move SCPs and see if failures follow the moved SCP. : If multiple channels have this failure, suspect motherboard.
308	<p>MUX. Checking turnover of the current output DACs.</p> <ul style="list-style-type: none"> : Tests Input Amplifier linearity more accurately than A/D Linearity Test 55. : Checks that the gain at -10.35mA is within 0.1% of the gain at +10.35mA. : Measured across the 69 Ohm resistor (R*40) on SCP. : Tested on E1532s. Also tests E1415/E1315 linearity. : Swap and/or move SCPs and see if failures follow the moved SCP. : If multiple channels have this failure, suspect motherboard.
313	<p>MUX. Checking output error on the voltage output DACs.</p> <ul style="list-style-type: none"> : Spec is 12mV at 0V's, 40mV at ± 8V's, 75mV at ± 15.5V's. : Measured across A/D input via the cal bus. : Tested on E1531s. : Swap and/or move SCPs and see if failures follow the moved SCP.
315	<p>MUX. Checking output error on the voltage output DACs.</p> <ul style="list-style-type: none"> : Spec is 12mV at 0V's, 40mV at ± 8V's, 75mV at ± 15.5V's. : Measured across SCP input via SCP sense resistors. : Tested on E1531s. : Swap and/or move SCPs and see if failures follow the moved SCP.
316	<p>MUX. Checking linearity of the voltage output DACs.</p> <ul style="list-style-type: none"> : Tests Input Amplifier linearity more accurately than A/D Linearity Test 55. : Checks that the gain at -8V & ±15.5V is within 0.1% of the gain at 8V. : Measured across SCP input via SCP sense resistors. : Tested on E1531s. Also tests E1415/E1315 linearity. : Swap and/or move SCPs and see if failures follow the moved SCP. : If multiple channels have this failure, suspect motherboard.
317	<p>MUX. Checking linearity of the voltage output DACs.</p> <ul style="list-style-type: none"> : Tests Input Amplifier linearity more accurately than A/D Linearity Test 55. : Checks that the gain at -8V & ±15.5V is within 0.1% of the gain at 8V. : Measured across A/D input via the cal bus. : Tested on E1531s. Also tests E1415/E1315 linearity. : Swap and/or move SCPs and see if failures follow the moved SCP. : If multiple channels have this failure, suspect motherboard.
318	<p>MUX. Checking turnover of the voltage output DACs.</p> <ul style="list-style-type: none"> : Tests Input Amplifier linearity more accurately than A/D Linearity Test 55. : Checks that the gain at -15.5V is within 0.1% of the gain at +15.5V. : Measured across SCP input via SCP sense resistors. : Measured across A/D input via the cal bus. : Tested on E1531s. Also tests E1415/E1315 linearity. : Swap and/or move SCPs and see if failures follow the moved SCP. : If multiple channels have this failure, suspect motherboard.
331	<p>MUX. Checking digital interface on the Digital IO SCP.</p> <ul style="list-style-type: none"> : With both channels set to be open collector outputs, sent and readback pattern via SCP serial data bus. : Tested on E1533s. : Swap and/or move SCPs and see if failures follow the moved SCP.

Table B-1. HP E1415A and HP E1419A Self Test Error Messages

Self Test Error Code	Description
332	<p>MUX. Checking Digital IO customer inputs and input pullups. : Both channels set to be inputs with pull-ups on and connected to open cal bus. Pattern expected is 10101010 -- low's are grounded. : Tested on E1533s. : Swap and/or move SCPs and see if failures follow the moved SCP.</p>
333	<p>MUX. Checking Digital IO customer inputs and input pullups. : Both channels set to be inputs with pull-ups on and connected to cal bus. Toggle odd bits one at a time. : Tested on E1533s. : Swap and/or move SCPs and see if failures follow the moved SCP.</p>
334	<p>MUX. Checking the Digital I/O's odd customer outputs. : Both channels set to be outputs with all outputs low and connected to cal bus. Toggle odd bits one at a time. : NOT open collector. : Tested bit is connected across the 7.5k cal bus resistor. : Tested on E1533s. : Swap and/or move SCPs and see if failures follow the moved SCP.</p>
335	<p>MUX. Checking that the Digital I/O's odd customer outputs go open collector. : Both channels set to be outputs with all outputs low and connected to cal bus. Toggle odd bits one at a time in open collector mode. : Tested bit is connected across the 7.5k cal bus resistor. : Tested on E1533s. : Swap and/or move SCPs and see if failures follow the moved SCP.</p>
336	<p>MUX. Checking the Digital I/O's even customer outputs. : Both channels set to be outputs with all outputs low and connected to cal bus. Toggle even bits one at a time sensing current through 1 Ohm Resistor on SCP. : NOTE: Even bits go to cal bus low which is always grounded. : Verifies current change on shorted output increases >4.5mA when toggled on. : NOT open collector. : Tested on E1533s. : Swap and/or move SCPs and see if failures follow the moved SCP.</p>
337	<p>MUX. Checking that the Digital I/O's even customer outputs go open collector. : Both channels set to be outputs with all outputs low and connected to cal bus. Toggle even bits one at a time sensing current through 1 Ohm Resistor on SCP. : NOTE: Even bits go to cal bus low which is always grounded. : Verifies current change on shorted output decreases >4.5mA when toggled to open collector mode. : Tested on E1533s. : Swap and/or move SCPs and see if failures follow the moved SCP.</p>
341	Checks Data 0 register for all channels on E1534A.
342	Checks Data 1 register for all channels on E1534A.
343	Parameter Register test on E1534A.
344	Command handshake test on E1534A.
345	CPU test on E1534A.
346	Inputs test on E1534A.
347	Outputs test on E1534A.
348	Output Type Control test on E1534A.
349	Output Interrupts test on E1534A.

Table B-1. HP E1415A and HP E1419A Self Test Error Messages

Self Test Error Code	Description
350	Tests the E1535 Control Register which contains the clock enable bit for the countdown timer. This is a read/write register that is accessed by the first channel of each SCP slot location and register location of 0. This bit controls the watchdog timer to go from the IDLE state to the RUNNING state and, back to IDLE unless enters the ALARM state when running. If ALARM then the watchdog timer will stay in the ALARM state until a *RST occurs. Swap positions and see if the failure follows the SCP.
351	Tests the E1535. Uses mux D to connect appropriate SCP bank, k2 cal-bus relay, k3 current source relay and, cal-resistor 7.5K to A/D input to measure the voltage of each E1535 reed relays. This test enters the RUNNING mode and closes all watchdog timer reed relays while at the same time sets the update bit to make sure the watchdog timer doesn't time-out. Then, through mux D will increment through all four relays one at a time and measure the voltage of each relay through the A/D, detecting if the relays are closed or open. If closed, the voltage read back should look like $120\mu\text{A} * (7.5\text{K} \parallel 51)[\text{ohms}] = \sim 6\text{mV} + \text{cal.offset}$. If the measurement is = to or less than 0.05V then it will pass this test. Swap positions and see if the failure follows the SCP.
352	Tests the E1535. Uses mux D to connect appropriate SCP bank, k2 cal-bus relay, k3 current source relay and, cal-resistor 7.5K to A/D input to measure the voltage of each E1535 reed relays. This test enters the RUNNING mode and makes sure all watchdog timer reed relays are open while at the same time sets the update bit to make sure the watchdog timer doesn't time-out. Then, through mux D will increment through all four relays one at a time and measure the voltage of each relay through the A/D, detecting if the relays are open. If open, the voltage read back should look like $120\mu\text{A} * 7.5\text{K}[\text{ohms}] = .9\text{V} + \text{cal. offset}$. If the measurement is = to or less than 1V it will pass this test. Swap positions and see if the failure follows the SCP.
353	Tests the E1535. Uses mux D to connect appropriate SCP bank, k2 cal-bus relay, k3 current source relay and, cal-resistor 7.5K to A/D input to measure the voltage of H4 which is the MOVn line (Disconnect Option). The function of this line is to signal the Cal relays to blow open when told to. This is an extra safety feature for the customer to drive if the DISC jumper is set. The voltage measurement looks like $120\mu\text{A} * (7.5\text{K} \parallel 51.1\text{K}) [\text{ohms}] = .78481\text{V} + \text{cal.offset}$. If the measurement is = to or less than .9V it will pass this test. Swap positions and see if the failure follows the SCP.
354	Tests the E1535. Uses mux D to connect appropriate SCP bank, k2 cal-bus relay, k3 current source relay and, cal-resistor 7.5K to A/D input to measure the voltage of H5. H5 is a pull-up supply provided for the customer if a switch is used to drive the Disconnect Option. The function of this line is to provide a signal to the Cal relays to blow open when told to. This is an extra safety feature for the customer to drive if the DISC jumper is set. The voltage measurement looks like $[(120\mu\text{A} * (7.5\text{K} \parallel 5.11\text{K}) [\text{ohms}]) + (5\text{V} * (7.5\text{K}/(5.11\text{K} + 7.5\text{K})))] = 3.3385\text{V} + \text{cal.offset}$. If the measurement is = to or less than 4V it will pass this test. Swap positions and see if the failure follows the SCP.
355	Tests the E1536. Toggles bits in the configuration register dedicated for Debounce Control Settings. It first writes 0505 (hex) and reads back to verify bits changed. Then writes 0A0A (hex) and reads back to verify bits. If this test failed, this would indicate that something may be wrong with the PROM or FPGA. The first thing to do is to swap to another SCP position and see if the failure follows the SCP.
356	Tests the E1536. This tests the functionality of the solid state relay. Using the current source of 120uA and closing the relay giving an on resistance of ~10 ohms across the output a voltage measurement will be made through the A/D and will be roughly .0012V +- offset error. If this test fails it is because the solid state relay didn't close and its off resistance is 10exp10 and will result as a very large voltage reading. If this test failed, this would indicate that the solid state relay may be damaged. The first thing to do is to swap to another SCP position and see if the failure follows the SCP.
357	Tests the E1536. This test drives the opto-couplers to see if they are functionally working. This test will scan through the channels and if any of the channels are set to the 5V, 12V, or 24V input thresholds they are driven with the on board voltage source set to 14V. A logic value of 1 should be read from that channel being tested. If the logic value of 0 is read then that would indicate that the opto-coupler was not successfully driven and it failed the test. If this test failed it may indicate that the opto-coupler may be damaged. The first thing to do is to swap to another SCP position and see if the failure follows the SCP.
358	Tests the E1536. This tests each channel if it is an input/threshold. If it is a 5V setting then it checks its high and low drive spec. It verifies that 1.4V gives low and 3V gives high. The 12V setting verifies that 3V gives low and 9V gives high. The 24V verifies that 5V gives low and 16V gives high. Finally, 48V setting verifies 9V gives low and high is not checked because of the voltage source +- limits. If this test fails it may indicate that there is a nominal switch setting and verify configuration of switches! It may also indicate that the opto-coupler is damaged. Swap to another SCP position and see if the failure follows the SCP.

Table B-2. HP E1415A General Error Messages

Code	Description	Comments
-108	Parameter not allowed.	
-109	Missing parameter	
-160	Block data error.	
-211	Trigger ignored.	
-212	Arm ignored.	
-213	INIT ignored.	
-221	Settings conflict.	
-222	Data out of range.	
-224	Illegal parameter value.	
-240	Hardware error. Execute *TST?.	
-253	Corrupt media.	
-281	Cannot create program.	
-282	Illegal program name.	
-310	System error.	
-410	Query INTERRUPTED.	
1000	Out of Memory	
2001	Invalid channel number.	
2003	Invalid word address.	
2007	Bus error.	
2008	Scan list not initialized.	
2009	Too many channels in channel list.	
2016	Byte count is not a multiple of two.	
3000	Illegal while initiated.	Operation must be performed before INIT or INIT:CONT ON.
3001	Illegal while continuous.	
3004	Illegal command. CAL:CONF not sent.	Incorrect sequence of calibration commands. Send CAL:CONF command before CAL:VAL command.
3005	Illegal command. Send CAL:VAL:RES.	The only command accepted after a CAL:CONF: RES is a CAL:VAL:RES command.
3006	Illegal command. Send CAL:VAL:VOLT.	The only command accepted after a CAL:CONF:VOLT is a CAL:VAL:VOLT command.
3007	Invalid signal conditioning module.	The command sent to an SCP was illegal for its type.
3008	Too few channels in scan list.	A Scan List must have at least two channels.
3012	Trigger too fast.	Scan List not completed before another trigger event occurs.
3015	Channel modifier not permitted here.	

Table B-2. HP E1415A General Error Messages

Code	Description	Comments
3019	TRIG:TIM interval too small for SAMP:TIM interval and scan list size.	TRIG:TIM interval must allow for completion of entire scan list at currently set SAMP:TIM interval.
3020	Input overvoltage.	Calibration relays opened (if JM2202 not cut) to protect module inputs, and Questionable Data Status bit 11 set. Execute *RST to close relays and/or reset status bit.
3021	FIFO overflow.	
3026	Calibration failed.	
3027	Unable to map A24 VXI memory.	
3028	Incorrect range value.	Range value sent is not supported by instrument.
3030	Command not yet implemented.	
3032	0x1: DSP-Unrecognized command code.	
3033	0x2: DSP-Parameter out of range.	
3034	0x4: DSP-Flash ROM erase failure.	
3035	0x8: DSP-Programming voltage not present.	
3036	0x10: DSP-Invalid SCP gain value.	Check that SCP is seated or replace SCP. Channel numbers are in FIFO.
3037	0x20: DSP-Invalid *CAL? constant or checksum. *CAL? required.	
3038	0x40: DSP- Could not cal some channels.	Check that SCP is seated or replace SCP. Channel numbers are in FIFO.
3039	0x80: DSP-Re-Zero of ADC failed.	
3040	0x100: DSP-Invalid Tare CAL constant or checksum.	Perform CAL:TARE - CAL:TARE? procedure.
3041	0x200: DSP-Invalid Factory CAL constant or checksum.	Perform A/D Cal procedure.
3042	0x400: DSP-DAC adjustment went to limit.	Execute *TST?
3043	0x800: DSP Status--Do *CAL?	
3044	0x1000: DSP-Overvoltage on input.	
3045	0x2000: DSP-reserved error condition.	
3046	0x4000: DSP-ADC hardware failure.	
3047	0x8000: DSP-reserved error condition.	
3048	Calibration or Test in Process.	
3049	Calibration not in Process.	
3050	ZERO must be sent before FSCale.	Perform A/D Cal sequence as shown in CAL:CONF:VOLT
3051	Memory size must be multiple of 4.	From MEM:VME:SIZE. Each HP E1415 reading requires 4 bytes.

Table B-2. HP E1415A General Error Messages

Code	Description	Comments
3052	Self test failed. Test info in FIFO.	<p>Use SENS:DATA:FIFO:ALL? to retrieve data from FIFO.</p> <p>NOTE: *TST? always sets the FIFO data FORMat to ASCII,7. Read FIFO data into string variables.</p> <p>A value of 1 through 99 is a failed test number. A value of 100 through 163 is a channel number for the failed test. A value of 200 through 204 is an A/D range number for the failed test where 200 = .0625V, 201 = .25V, 202 = 1V, 203 = 4V, and 204 = 16V range. For example, if DATA:FIFO? returns the values 72 and 108, this indicates that test number 72 failed on channel 8.</p> <p>Test numbers 20, 30-37, 72, 74-76 may indicate a problem with a Signal Conditioning Plug-on. For tests 20 and 30-37, remove all SCPs and see if *TST? passes. If so, replace SCPs one at a time until you find the one causing the problem.</p> <p>For tests 72, and 74-76, try to re-seat the SCP that the channel number(s) points to, or move the SCP and see if the failure(s) follow the SCP. If the problems move with the SCP, replace the SCP. Refer to the *TST? command for a list of module functions tested.</p> <p>NOTE: During the first 5 minutes after power is applied, *TST? may fail. Allow the module to warm up before executing *TST?.</p>
3053	Corrupt on board Flash memory.	
3056	Custom EU not loaded.	May have erased custom EU conversion table with *RST. May have linked channel with standard EU after loading custom EU, this erases the custom EU for this channel. Reload custom EU table using DIAG:CUST:LIN or DIAG:CUST:PIEC.
3057	Invalid ARM or TRIG source when S/H SCP's enabled.	Don't set TRIG:SOUR or ARM:SOUR to SCP with HP E1510 or HP E1511 installed.
3058	Hardware does not have D32, S/H, or new trigger capabilities.	Module's serial number is earlier than 3313A00530.
3067	Multiple attempts to erase Flash Memory failed.	
3068	Multiple attempts to program Flash Memory failed.	
3069	Programming voltage jumper not set properly.	
3070	Identification of Flash ROM incorrect.	
3071	Checksum error on Flash Memory.	
3074	WARNING! Old Opt 16 or Opt 17 card can damage SCP modules.	Must use HP E1506 or HP E1507.
3075	Too many entries in CVT list.	
3076	Invalid entry in CVT list' Can only be 10 to 511.	
3077	Too many updates in queue. Must send UPDATE command.	To allow more updates per ALG:UPD, increase ALG:UPD:WINDOW.
3078	Invalid Algorithm name.	Can only be 'ALG1' through 'ALG32' or 'GLOBALS' or 'MAIN.
3079	Algorithm is undefined.	In ALG:SCAL, ALG:SCAL?, ALG:ARR, or ALG:ARR?

Table B-2. HP E1415A General Error Messages

Code	Description	Comments
3080	Algorithm already defined.	Trying to repeat ALG:DEF with same <alg_name> (and is not enabled to swap), or trying to define 'GLOBALS' again since last *RST.
3081	Variable is undefined.	Algorithm exists but has no local variable by that name.
3082	Invalid Variable name.	Must be valid 'C' identifier, see User Manual Chapter 5.
3083	Global symbol (variable or custom function) already defined.	Trying to define a global variable with same name as a user defined function, or vice versa. User functions are also global.
3084	Algorithmic error queue full.	<p>ALG:DEF has generated too many errors from your algorithm source code.</p> <p>"Error 1: Number too big for a 32 bit float"</p> <p>"Error 2: Number too big for a 32 bit integer"</p> <p>"Error 3: '8' or '9' not allowed in an octal number"</p> <p>"Error 4: Syntax error"</p> <p>"Error 5: Expecting '('"</p> <p>"Error 6: Expecting ')"</p> <p>"Error 7: Expecting an expression"</p> <p>"Error 8: Out of driver memory"</p> <p>"Error 9: Expecting a bit number (Bn or Bnn)"</p> <p>"Error 10: Expecting ']'"</p> <p>"Error 11: Expecting an identifier"</p> <p>"Error 12: Arrays can't be initialized"</p> <p>"Error 13: Expecting 'static'"</p> <p>"Error 14: Expecting 'float'"</p> <p>"Error 15: Expecting ';'"</p> <p>"Error 16: Expecting ','"</p> <p>"Error 17: Expecting '='"</p> <p>"Error 18: Expecting '{'"</p> <p>"Error 19: Expecting '}'"</p> <p>"Error 20: Expecting a statement"</p> <p>"Error 21: Expecting 'if'"</p> <p>"Error 22: Can't write to input channels"</p> <p>"Error 23: Expecting a constant expression"</p> <p>"Error 24: Expecting an integer constant expression"</p> <p>"Error 25: Reference to an undefined variable"</p> <p>"Error 26: Array name used in a scalar context"</p> <p>"Error 27: Scalar name used in an array context"</p> <p>"Error 28: Variable name used in a custom function context"</p> <p>"Error 29: Reference to an undefined custom function"</p> <p>"Error 30: Can't have executable code in GLOBALS definition"</p> <p>"Error 31: CVT address range is 10 - 511"</p> <p>"Error 32: Numbered algorithms can only be called from MAIN"</p> <p>"Error 33: Reference to an undefined algorithm"</p> <p>"Error 34: Attempt to redefine an existing symbol (var or fn)"</p> <p>"Error 35: Array size is 1 - 1024"</p> <p>"Error 36: Expecting a default PID parameter"</p> <p>"Error 37: Too many FIFO or CVT writes per scan trigger"</p> <p>"Error 38: Statement is too complex"</p> <p>"Error 39: Unterminated comment"</p>
3085	Algorithm too big.	Algorithm exceeded 46K words (23K if enabled to swap), or exceeded size specified in <swap_size>.
3086	Not enough memory to compile Algorithm.	Your algorithm's constructs are using too much translator memory. Need more memory in your HP E1406. Try breaking your algorithm into smaller algorithms.

Table B-2. HP E1415A General Error Messages

Code	Description	Comments
3088	Too many functions.	Limit is 32 user defined functions
3089	Bad Algorithm array index.	Must be from 0 to (declared size)-1
3090	Algorithm Compiler Internal Error.	Call HP with details of operation.
3091	Illegal while not initiated.	Send INIT before this command.
3092	No updates in queue.	
3093	Illegal Variable Type.	Sent ALG:SCAL with identifier of array, ALG:ARR with scalar identifier, ALG:UPD:CHAN with identifier that is not a channel, etc.
3094	Invalid Array Size' Must be 1 to 1024.	
3095	Invalid Algorithm Number.	Must be 'ALG1' to 'ALG32.
3096	Algorithm Block must contain termination.	Must append a null byte to end of algorithm string within the Block Data.
3097	Unknown SCP. Not Tested.	May receive if you are using a breadboard SCP
3099	Invalid SCP for this product.	
3100	Analog Scan time to big. Too much settling time.	Count of channels referenced by algorithms combined with use of SENS:CHAN:SETTLING has attempted to build an analog Scan List greater than 64 channels.
3101	Can't define new algorithm while running.	Execute ABORT, then define algorithm
3102	Need ALG:UPD before redefining this algorithm again.	Already have an algorithm swap pending for this algorithm.
3103	Algorithm swapping already enabled; Can't change size.	Only send <swap_size> parameter on initial definition.
3104	GLOBALS can't be enabled for swapping.	Don't send <swap_size> parameter for ALG:DEF 'GLOBALS'.

Appendix C

Command Reference

Introduction

This appendix describes the Standard Commands for Programmable Instruments (SCPI) CALibration commands and IEEE-488.2 Common Commands for the HP E1415A and HP E1419A. Commands are listed alphabetically within each subsystem. See *Chapter 6 - Command Reference* in the *HP E1415A User's Manual* or *HP E1419A User's Manual* for command fundamentals.

CALibration Commands

The CALibration subsystem commands provide two major categories of calibration: A/D Calibration and Working Calibration.

A/D Calibration

For this procedure, an external multimeter is used to determine the actual voltage and resistance values of the HP E1415/E1419's internal calibration sources. The known values are then sent to the HP E1415/E1419 where they are stored and used to perform internal A/D calibration.

A/D calibration requires a series of CALibration commands (**CAL:CONF...**, **CAL:VAL...**, and **CAL:STORE ADC**). See *Chapter 3 - Adjustments* for the procedure. Always execute ***CAL?** or a **CAL:TARE** operation after A/D calibration.

Working Calibration

As shown in Figure C-1, there are three levels of "working calibration": A/D Zero, Channel Calibration, and Channel Tare.

A/D Zero (CAL:ZERO?): This function quickly compensates for any short term A/D converter offset drift (the autozero function in a conventional voltmeter).

Channel Calibration (*CAL? or CAL:SETup): This function corrects for offset and gain errors, thermal offsets, and component drift for each channel out to the input side of the SCP.

Channel Tare (CAL:TARE): This function corrects for voltage offsets in external (user) system wiring. The user places a short across the transducer wiring and the voltage that the HP E1415/E1419 measures is now considered the new "zero" value for that channel. The new offset can be stored in non-volatile calibration memory (with **CAL:STOR TARE**) but is in effect whether stored or not. **CAL:TARE** automatically executes a ***CAL?** command.

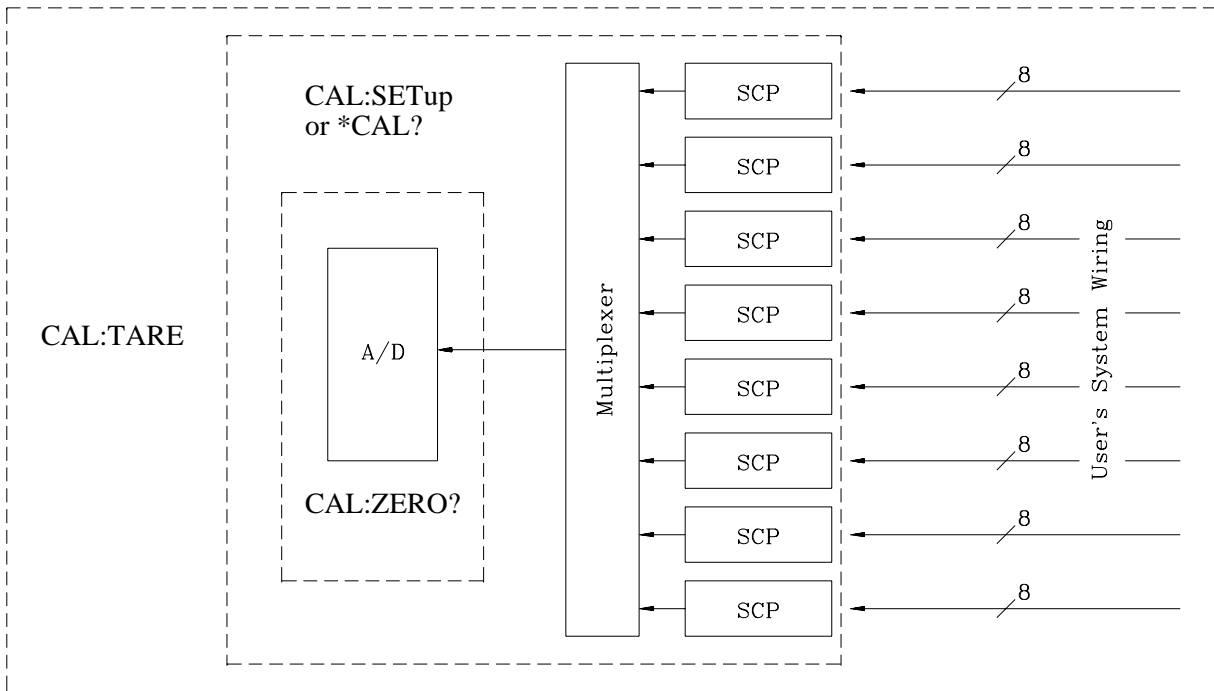

Figure C-1. Working Calibration Levels

Subsystem Syntax

```

CALibration
:CONFigure
:RESistance
:VOLTage <range>, ZERO | FS
:SETup
:SETup?
:STORe ADC | TARE
:TARE (@<ch_list>)
:RESet
:TARE?
:VALue
:RESistance <ref_ohms>
:VOLTage <ref_volts>
:ZERO?

```

CALibration:CONFigure:RESistance

CALibration:CONFigure:RESistance connects the on-board reference resistor to the Calibration Bus. A four-wire measurement of the resistor can be made with an external multimeter connected to the **HCAL**, **LCAL**, **HOHM**, and **LOHM** terminals on the terminal module or to the **VH**, **VL**, **Ω H**, and **Ω L** terminals on the Cal Bus connector.

Comments • **Related Commands:** CAL:VAL:RES, CAL:STOR ADC

Command Sequence CAL:CONF:RES *connect reference resistor to Calibration Bus*
 *OPC? or SYST:ERR? *must wait for CAL:CONF:RES to complete*
 (now measure ref resistor with external DMM)
 CAL:VAL:RES <measured value> *Send measured value to module*
 CAL:STORE ADC *Store cal constants in non-volatile memory (used only at end of complete cal sequence)*

CALibration:CONFigure:VOLTage

CALibration:CONFigure:VOLTage <range>,<zero_fs> connects the on-board voltage reference to the Calibration Bus. A measurement of the source voltage can be made with an external multimeter connected to the **HCAL** and **LCAL** terminals on the terminal module or to the **VH** and **VL** terminals on the Cal Bus connector. The *range* parameter controls the voltage level available when the *zero_fs* parameter is FSCale (full scale).

Parameters

Parameter Name	Parameter Type	Range of Values	Default Units
range	numeric (float32)	see comments	volts
zero_fs	discrete (string)	ZERO FSCale	none

Comments

- The *range* parameter must be within 5% of one of the 5 following values: .0625VDC, .25VDC, 1VDC, 4VDC, 16VDC. Range may be specified in millivolts (mV).
- The FSCALE output voltage of the calibration source should be greater than 90% of the nominal value for each range, except the 16V range where the output is 10V.
- **Related Commands:** CAL:VAL:VOLT, CAL:STOR ADC

Usage CAL:CONF:VOLT .25, ZERO *Voltage reference set to .25V range and zero output*
 CAL:CONF:VOLT .25, FSCALE *Set same range but full-scale output*

Command Sequence CAL:CONF:VOLTAGE .0625, ZERO *connect voltage reference to Calibration Bus*
 *OPC? or SYST:ERR? *Wait for CAL:CONF: VOLT to*

(now measure voltage with external DMM)
 CAL:VAL:VOLT <measured value> *Send measured value to module*
 repeat above sequence for full-scale
 repeat zero and full-scale for remaining ranges (.25, 1, 4, 16)
 CAL:STORE ADC *Store cal constants in non-volatile memory (used only at end of cal seq)*

CALibration:SETup

CALibration:SETup causes the Channel Calibration function to be performed for every module channel. The Channel Calibration function calibrates the A/D Offset and the Gain/Offset for all 64 channels. This calibration is accomplished using internal calibration references. Since this is time-consuming, you may want to run many at once rather than one at a time.

CAL:SET performs the same operation as the *CAL? command except that since it is not a query command it does not tie up the C-SCPI driver waiting for response data from the instrument. If you have multiple HP E1415A's or HP E1419's in your system, you can start a CAL:SET operation on each and then execute a CAL:SET? command to complete the operation on each instrument.

- **Related Commands:** CAL:SETup?, *CAL?

Usage	CAL:SET	<i>start SCP Calibration on 1st HP E1415 or E1419</i>
	:	<i>start SCP Calibration on more HP E1415s or E1419s</i>
	CAL:SET	<i>start SCP Calibration on last HP E1415 or E1419</i>
	CAL:SET?	<i>query for results from 1st HP E1415 or E1419</i>
	:	<i>query for results from more HP E1415s or E1419s</i>
	CAL:SET?	<i>query for results from last HP E1415 or E1419</i>

CALibration:SETup?

CALibration:SETup? returns a value to indicate the success of the last CAL:SETup or *CAL? operation. CAL:SETup? returns the value only after the CAL:SETup operation is complete.

Comments • **Returned Value:**

Value	Meaning	Further Action
0	Cal OK	None
-1	Cal Error	Query the Error Queue (SYST:ERR?) See Appendix B. Also run *TST?
-2	No results available	No *CAL? or CAL:SETUP done

The C-SCPI type for this returned value is **int16**.

• **Related Commands:** CAL:SETup, *CAL?

Usage see CAL:SETup

CALibration:STORE

CALibration:STORE <type> stores the most recently measured calibration constants into Flash Memory (Electrically Erasable Programmable Read Only Memory). When *type* = ADC, the module sets its Analog-to-Digital Converter calibration using the most recently measured CAL:VALues for voltage and resistance, and stores these to Flash Memory. When *type* = TARE, the module stores the most recently measured CAL:TARE channel offsets into Flash Memory.

Note The HP E1415A and HP E1419A Flash Memory has a finite lifetime of approximately ten thousand write cycles (unlimited read cycles). While executing CAL:STOR once every day would not exceed the lifetime of the Flash Memory for approximately 27 years, an application that stored constants many times each day would unnecessarily shorten the Flash Memory's lifetime. See Comments below.

Parameters

Parameter Name	Parameter Type	Range of Values	Default Units
type	discrete (string)	ADC TARE	none

Comments • The Flash Memory Enable jumper (JM 2201) must be set to the enable position before executing this command (See *Chapter 3 - Adjustments*).

- Channel offsets are compensated by the CAL:TARE command even when not stored in the Flash Memory. There is no need to use the CAL:STORE TARE command for channels which are re-calibrated frequently.
- **Related Commands:** CAL:VAL:RES, CAL:VAL:VOLT
- ***RST Condition:** Stored calibration constants are unchanged.

Usage	CAL:STORE ADC	<i>Store cal constants in non-volatile memory after A/D calibration</i>
	CAL:STORE TARE	<i>Store channel offsets in non-volatile memory after channel tare</i>

Command Sequence	Storing A/D cal constants	
	perform complete A/D calibration, then...	
	CAL:STORE ADC	
	Storing channel tare (offset) values	
	CAL:TARE <ch_list>	<i>to correct channel offsets</i>
	CAL:STORE TARE	<i>Optional - depends on long term storage req</i>

CALibration:TARE

CALibration:TARE (@<ch_list>) measures the voltage present on the channels specified and stores the value in on-board RAM as a calibration constant for those channels. Future measurements made with the channels will be compensated by the amount of the tare value.

Use CAL:TARE to compensate for voltage offsets in transducer wiring. Where tare values need to be retained for long periods, they can be stored in the module's Flash Memory (Electrically Erasable Programmable Read Only Memory) by executing the CAL:STORE TARE command.

Note The HP E1415A and HP E1419A Flash Memory has a finite lifetime of approximately ten thousand write cycles (unlimited read cycles). While executing CAL:STOR once every day would not exceed the lifetime of the Flash Memory for approximately 27 years, an application that stored constants many times each day would unnecessarily shorten the Flash Memory's lifetime.

Note If Open Transducer Detect (OTD) is enabled when CAL:TARE is executed, the module will disable OTD, wait 1 minute to allow channels to settle, perform the calibration, and then re-enable OTD. If your program turns off OTD before executing CAL:TARE, it should also wait 1 minute for settling.

Parameters

Parameter Name	Parameter Type	Range of Values	Default Units
ch_list	channel list (string)	100 - 163	none

Comments

- Channel offsets are compensated by the CAL:TARE command even when not stored in the Flash Memory. There is no need to use the CAL:STORE TARE command for channels which are re-calibrated frequently.
- Set Amplifier/Filter SCP gain before CAL:TARE. For best accuracy, choose the gain that will be used during measurements.
- Executing CAL:TARE sets the Calibrating bit (bit 0) in Operation Status Group. Executing CAL:TARE? resets the bit.
- **Related Commands:** CAL:TARE?, CAL:STOR TARE
- ***RST Condition:** Channel offsets are not affected by *RST.

Command Sequence

CAL:TARE <ch_list>
 CAL:TARE? *to correct channel offsets
 to return the success flag from
 the CAL:TARE operation*

CAL:STORE TARE *Optional - depends on long
 term storage req*

CALibration:TARE:RESet

CALibration:TARE:RESet resets the tare calibration constants to zero for all 64 channels. Executing CAL:TARE:RES affects the tare cal constants in RAM only. To reset the tare cal constants in Flash Memory, execute CAL:TARE:RES and then execute CAL:STORE TARE.

Command Sequence

CAL:TARE:RESET
 CAL:STORE TARE *to reset channel offsets
 Optional if necessary to reset
 tare cal constants in Flash
 Memory.*

specified in Kohm.

- A four-wire measurement of the resistor can be made with an external multimeter connected to the **HCAL**, **LCAL**, **HOHM**, and **LOHM** terminals on the terminal module or to the **VH**, **VL**, **Ω H**, and **Ω L** terminals on the Cal Bus connector.
- Use the **CAL:CONF:RES** command to configure the reference resistor for measurement at the Calibration Bus connector.
- **Related Commands:** **CAL:CONF:RES**, **CAL:STORE ADC**

Usage CAL:VALUE:RESISTANCE <measured value>

Command Sequence CAL:CONF:RES
(now measure ref resistor with external DMM)
CAL:VAL:RES <measured value> *Send measured value to module*

CALibration:VALue:VOLTage

CALibration:VALue:VOLTage <ref_volts> sends the value of the DC reference source to the module for A/D calibration.

Parameters

Parameter Name	Parameter Type	Range of Values	Default Units
ref_volts	numeric (float 32)	must be within 10% of range nominal	volts

Comments

- *ref_volts* may be specified in millivolts (mV).
- A measurement of the source voltage can be made with an external multimeter connected to the **HCAL** and **LCAL** terminals on the terminal module or to the **VH** and **VL** terminals on the Cal Bus connector.
- Use the **CAL:CONF:VOLT** command to configure the on-board voltage source for measurement at the Calibration Bus connector.
- The value sent must be for the currently configured range and output (zero or full scale) as set by the previous **CAL:CONF:VOLT** <range>, **ZERO** | **FSCale** command.
- **Related Commands:** **CAL:CONF:VOLT**, **CAL:STORE ADC**

Usage CAL:VALUE:VOLTAGE <measured value>

Command Sequence

CAL:CONF:VOLTAGE 4,FSCALE

*OPC?

Wait for operation to complete

ENTER statement

(now measure voltage with external DMM)

CAL:VAL:VOLT <measured value>

*Send measured value to module***CALibration:ZERO?**

CALibration:ZERO? corrects Analog to Digital converter offset for any drift since the last *CAL? or CAL:ZERO? command was executed.**Comments**

- The CAL:ZERO? command only corrects for A/D offset drift (zero). Use the *CAL? common command to perform on-line calibration of channels as well as A/D offset. *CAL? performs gain and offset correction of the A/D and each channel out to the field wiring connector.

- **Returned Value:**

Value	Meaning	Further Action
0	Cal OK	None
-1	Cal Error	Query the Error Queue (SYST:ERR?) See Error Messages in <i>Appendix B - Error Messages</i>

The C-SCPI type for this returned value is **int16**.

- Executing this command **does not** alter the module's programmed state (function, range, etc.).
- **Related Commands:** *CAL?
- ***RST Condition:** A/D offset performed

Usage

CAL:ZERO?

enter statement here

returns 0 or -1

DIAGnostic

The DIAGnostic subsystem allows you to perform special operations that are not standard in the SCPI language. This includes checking the current revision of the Control Processor's firmware, and that it has been properly loaded into Flash Memory.

Subsystem Syntax

```
DIAGnostic
:CALibration
:SETup
  :MODE 0 | 1
  :MODE?
:TARe
  [:OTD]
  :MODE 0 | 1
  :MODE?
:CHECKsum?
:CUSTom
  :LINear <table_range>,<table_block>,(@<ch_list>)
  :PIECewise <table_range>,<table_block>,(@<ch_list>)
:REFerence
  :TEMPerature
:FLOOR[:CONFigure] <range>,(@<ch_list>)
:DUMP
:IEEE 1 | 0
:IEEE?
:INTerrupt
  [:LINE] <intr_line>
  [:LINE]?
:OTDetect
  [:STATE] 1 | 0 | ON | OFF,(@<ch_list>)
  [:STATE]? (@<channel>)
:QUERY
  :SCPREAD? <reg_addr>
:VERsion?
```

DIAGnostic:CALibration:SETup[:MODE]

DIAGnostic:CALibration:SETup[:MODE] *<mode>* sets the type of calibration to use for analog output SCPIs like the HP E1531 and HP E1532 when *CAL? or CAL:SET are executed.

Parameters

Parameter Name	Parameter Type	Range of Values	Default Units
<i>mode</i>	boolean (uint 16)	0 1	volts

Comments

- When *<mode>* is set to 1 (the *RST Default) channels are calibrated using the Least Squares Fit method to provide the minimum error overall (over the entire output range). When *<mode>* is 0, channels are calibrated to provide the minimum error at their zero point. See your SCPs User's Manual for its accuracy specifications using each mode.

- Related Commands:** *CAL?, CAL:SET, DIAG:CAL:SET:MODE?

- *RST Condition:** DIAG:CAL:SET:MODE 1

Usage

set analog DAC SCP cal mode for best zero accuracy
DIAG:CAL:SET:MODE 0 *set mode for best zero cal*
*CAL? *start channel calibration*

DIAGnostic:CALibration:SETup[:MODE]?

DIAGnostic:CALibration:SETup[:MODE]? returns the currently set calibration mode for analog output DAC SCPs.

Comments

- Returns a 1 when channels are calibrated using the Least Squares Fit method to provide the minimum error overall (over the entire output range). Returns a 0 when channels are calibrated to provide the minimum error at their zero point. See your SCPs User's Manual for its accuracy specifications using each mode. The C-SCPI type is **int16**.

- Related Commands:** DIAG:CAL:SET:MOD, *CAL?, CAL:SET

- *RST Condition:** DIAG:CAL:SET:MODE 1

DIAGnostic:CALibration:TARE[:OTDetect]:MODE

DIAGnostic:CALibration:TARE[:OTDetect]:MODE <mode> sets whether Open Transducer Detect current will be turned off or left on (the default mode) during the CAL:TARE operation.

Parameters

Parameter Name	Parameter Type	Range of Values	Default Units
<i>mode</i>	boolean (uint 16)	0 1	volts

Comments

- When *<mode>* is set to 0 (the *RST Default), channels are tare calibrated with their OTD current off. When *<mode>* is 1, channels that have their OTD current on (DIAGnostic:OTDetect ON,(*@<ch_list>*)) are tare calibrated with their OTD current left on.
- By default (*RST) the CALibration:TARE? command will calibrate all channels with the OTD circuitry disabled. This is done for two reasons: first, most users do not leave OTD enabled while taking readings, and second, the CALibration:TARE? operation takes much longer with OTD enabled. However, for users who intend to take readings with OTD enabled, setting DIAG:CAL:TARE:OTD:MODE to 1, will force the CAL:TARE? command to perform calibration with OTD enabled on channels so specified by the user with the DIAG:OTD command.
- **Related Commands:** *CAL?, CAL:SET, DIAG:CAL:SET:MODE?
- ***RST Condition:** DIAG:CAL:TARE:MODE 0

Usage

configure OTD on during CAL:TARE
DIAG:CAL:TARE:MODE 1
CAL:TARE?

*set mode for OTD to stay on
start channel tare cal.*

DIAGnostic:CALibration:TARE[:OTDetect]:MODE?

DIAGnostic:CALibration:TARE[:OTDetect]:MODE? returns the currently set mode for controlling Open Transducer Detect current while performing CAL:TARE? operation.

Comments

- Returns a 0 when OTD current will be turned off during CAL:TARE?. Returns 1 when OTD current will be left on during CAL:TARE? operation. The C-SCPI type is **int16**.
- **Related Commands:** DIAG:CAL:TARE:MOD, DIAG:OTD, CAL:TARE?
- ***RST Condition:** DIAG:CAL:TARE:MODE 0

DIAGnostic:CHECKsum?

DIAGnostic:CHECKsum? performs a checksum operation on Flash Memory. A returned value of 1 indicates that Flash memory contents are correct. A returned value of 0 indicates that the Flash Memory is corrupted, or has been erased.

Comments

- **Returned Value:** Returns 1 or 0. The C-SCPI type is **int16**.

DIAGnostic:CUSTom:LINEar

**DIAGnostic:CUSTom:LINEar <table_range>,<table_block>,
(@<ch_list>)** downloads a custom linear Engineering Unit Conversion table (in <table_block>) to the HP E1415 or HP E1419. Contact your Hewlett-Packard System Engineer for more information on Custom Engineering Unit Conversion for your application.

Parameters

Parameter Name	Parameter Type	Range of Values	Default Units
<i>table_range</i>	numeric (float32)	.015625 .03125 .0625 .125 .25 .5 1 2 4 8 16 32 64	volts
<i>table_block</i>	definite length block data	see comments	none
<i>ch_list</i>	channel list (string)	100 - 163	none

Comments

- <table_block> is a block of 8 bytes that define 4, 16-bit values. SCPI requires that <table_block> include the definite length block data header. C-SCPI adds the header for you.
- <table_range> specifies the range of voltage that the table covers (from -<table_range> to +<table_range>). The value you specify must be within 5% of one of the nominal values from the table above.
- <ch_list> specifies which channels may use this custom EU table
- **Related Commands:** [SENSe:]FUNctioN:CUSTom
- ***RST Condition:** All custom EU tables erased

Usage

program puts table constants into array table_block
 DIAG:CUST:LIN table_block,(@116:123) *send table to HP E1415/19 for chs 16-23*
 SENS:FUNC:CUST:LIN 1,1,(@116:123) *link custom EU with chs 16-23*
 INITiate then TRIGger module

DIAGnostic:CUSTom:PIECewise

**DIAGnostic:CUSTom:PIECewise <table_range>,<table_block>,
(@<ch_list>)** downloads a custom piece wise Engineering Unit Conversion table (in <table_block>) to the HP E1415 or HP E1419. Contact your Hewlett-Packard System Engineer for more information on Custom Engineering Unit Conversion for your application.

Parameters

Parameter Name	Parameter Type	Range of Values	Default Units
<i>table_range</i>	numeric (float32)	.015625 .03125 .0625 .125 .25 .5 1 2 4 8 16 32 64	volts
<i>table_block</i>	definite length block data	see comments	none
<i>ch_list</i>	channel list (string)	100 - 163	none

Comments

- *<table_block>* is a block of 1,024 bytes that define 512 16-bit values. SCPI requires that *<table_block>* include the definite length block data header. C-SCPI adds the header for you.
- *<table_range>* specifies the range of voltage that the table covers (from *-<table_range>* to *+<table_range>*).
- *<ch_list>* specifies which channels may use this custom EU table.
- **Related Commands:** [SENSe:]FUNcTION:CUStom
- ***RST Condition:** All custom EU tables erased.

Usage

program puts table constants into array *table_block*
 DIAG:CUSt:PIEC *table_block*,(@124:131) *send table for chs 24-31 to HP E1415 or HP E1419*
 SENS:FUNc:CUSt:PIEC 1,1,(@124:131) *link custom EU with chs 24-31*
 INITiate then TRIGger module

DIAGnostic:CUStom:REfERENCE:TEMPerature

DIAGnostic:CUStom:REfERENCE:TEMPerature extracts the current Reference Temperature Register Contents, converts it to 32-bit floating point format and sends it to the FIFO. This command is used to verify that the reference temperature is as expected after measuring it using a custom reference temperature EU conversion table.

Usage

your program must have EU table values stored in *table_block*
download the new reference EU table
 DIAG:CUSt:PIECEWISE *<table_range>*,*<table_block>*,(@*<ch_list>*)
designate channel as reference
 SENS:FUNc:CUSt:REF *<range>*,(@*<ch_list>*)
set up scan list sequence (ch 0 in this case)
 Now run the algorithm that uses the custom reference conversion table
dump reference temp register to FIFO
 DIAG:CUSt:REF:TEMP
read the diagnostic reference temperature value
 SENS:DATA:FIFO?

DIAGnostic:FLOor[:CONFigure]

DIAGnostic:FLOor[:CONFigure] *<range>*,(@*<ch_list>*) sets the lowest range that can be selected by auto range on channels specified in *<ch_list>*.

Parameters

Parameter Name	Parameter Type	Range of Values	Default Units
<i>range</i>	numeric (float32)	see comments	VDC
<i>ch_list</i>	channel list (string)	100 - 163	none

Comments

- There are rare circumstances where your input signal can be difficult for the HP E1415/19 to auto range correctly. The module completes the range selection based on your input signal about 6 μ sec before the actual measurement is made on that channel. If during that period your signal becomes greater than the selected range can handle, the module will return an overflow reading (\pm INFINITY). By locking-out that range (and lower ranges) for this channel, the module can continue to auto-range and still avoid the overflow reading condition.
- The *<range>* parameter: The HP E1415/E1419 has five ranges: .0625VDC, .25VDC, 1VDC, 4VDC, and 16VDC. To select a range, simply specify the range value (for example, 4 selects the 4VDC range). If you specify a value larger than one of the first four ranges, the HP E1415/E1419 selects the next higher range (for example, 4.1 selects the 16VDC range). Specifying a value larger than 16 causes an error. Specifying 0 selects the lowest range (.0625VDC).
- Once a channel's auto range floor is set by DIAG:FLOOR, it remains until reset by another DIAG:FLOOR command or the *RST command.
- A channel with an auto range floor can be manually ranged below the floor (SENS:FUNC... commands). When the channel is returned to auto range, the auto range floor setting is still in effect.
- **Related Commands:** DIAG:FLOOR:DUMP?, SENS:FUNC...
- **Power-on and *RST Condition:** DIAG:FLOOR .0625,(@100:163)

Usage DIAG:FLOOR .25,(@100:104)

channels 0-4 can range no lower than .25

DIAGnostic:FLOor:DUMP

DIAGnostic:FLOor:DUMP places the auto range floor value for all 64 channels into the FIFO.

Comments

- The format of the values returned from the FIFO with a SENS:DATA? command will depend on the format chosen with the FORMat[:DATA] command.
- **Related commands:** DIAG:FLOor, FORMat[:DATA], SENS:FUNC...

DIAGnostic:IEEE

DIAGnostic:IEEE <mode> enables (1) or disables (0) IEEE-754 NAN (Not A Number) and \pm INF value outputs. This command was created for the HP VEE platform.

Parameters

Parameter Name	Parameter Type	Range of Values	Default Units
<i>mode</i>	boolean (uint 16)	0 1	volts

Comments

- When <mode> is set to 1, the module can return \pm INF and NAN values according to the IEEE-754 standard. When <mode> is set to 0, the module returns values as \pm 9.9E37 for INF and 9.91E37 for NAN.
- **Related Commands:** DIAG:IEEE?
- ***RST Condition:** DIAG:IEEE 1

Usage

Set IEEE mode

DIAG:IEEE 1

INF values returned in IEEE standard

DIAGnostic:IEEE?

DIAGnostic:IEEE? returns the currently set IEEE mode.

Comments

- The C-SCPI type is **int16**.
- **Related Commands:** DIAG:IEEE
- ***RST Condition:** DIAG:IEEE 1

DIAGnostic:INTerrupt[:LINE]

DIAGnostic:INTerrupt[:LINE] <intr_line> sets the VXIbus interrupt line the module will use.

Parameters

Parameter Name	Parameter Type	Range of Values	Default Units
<i>intr_line</i>	numeric (int16)	0 through 7	none

Comments

- **Related Commands:** DIAG:INT:LINE?
- **Power-on and *RST Condition:** DIAG:INT:LINE 1

Usage

DIAG:INT:LINE 5

Module will interrupt on interrupt line 5

DIAGnostic:INTerrupt[:LINE]?

DIAGnostic:INTerrupt[:LINE]? returns the VXIbus interrupt line that the module is set to use.

Comments

- **Returned Value:** Numeric 0 through 7. The C-SCPI type is **int16**.
- **Related Commands:** DIAG:INT:LINE

Usage

DIAG:INT?

Enter statement will return 0 through 7

DIAGnostic:OTDetect[:STATE]

DIAGnostic:OTDetect[:STATE] *<enable>*,(@*<ch_list>*) enables and disables the HP E1415's or HP E1419's "Open Transducer Detection" capability (OTD). When Open Transducer Detection is enabled, a very high impedance path connects all SCP channels to a voltage source greater than 16 volts. If an enabled channel has an open transducer, the input signal becomes the source voltage and the channel returns an input over-range value. The value returned is +9.91E+37 (ASCII).

Parameters

Parameter Name	Parameter Type	Range of Values	Default Units
<i>enable</i>	boolean (uint16)	1 0 ON OFF	none
<i>ch_list</i>	channel list (string)	100 - 163	none

Comments

- Open Transducer Detection is enabled/disabled on a whole Signal Conditioning Plug-on basis. Selecting any channel on an SCP selects all channels on that SCP (8 channels per SCP).
- The DIAG:CAL:TARE:MODE *<mode>* command affects how OTD

is controlled during the CAL:TARE? operation. When *<mode>* is set to 0 (the *RST Default), channels are tare calibrated with their OTD current off. When *<mode>* is 1, channels that have their OTD current on (DIAGnostic:OTDetect ON,(@<ch_list>)) are tare calibrated with their OTD current left on.

- **Related Commands:** DIAG:OTDETECT:STATE?,
DIAG:CAL:TARE:MODE

Note *RST Condition: DIAG:OTDETECT OFF

If OTD is enabled when *CAL?, or CAL:TARE is executed, the module will disable OTD, wait 1 minute to allow channels to settle, perform the calibration, and then re-enable OTD.

Usage DIAG:OTD ON,(@100:107,115:123) *select OTD for the first and third SCP (complete channel lists for readability only)*

DIAG:OTD:STATE ON,(@100,115) *same function as example above (only first channel of each SCP specified)*

DIAG:OTDETECT:STATE OFF,(@108) *disable OTD for the 8 channels on the second SCP (only first channel of SCP specified)*

DIAGnostic:OTDetect[:STATE]?

DIAGnostic:OTDetect[:STATE]? (@<channel>) returns the current state of "Open Transducer Detection" for the SCP containing the specified channel.

Parameters

Parameter Name	Parameter Type	Range of Values	Default Units
<i>channel</i>	channel list (string)	100 - 163	none

Comments

- *channel* must specify a single channel only.
- **Returned Value:** Returns 1 (enabled) or 0 (disabled). The C-SCPI type is **int16**.
- **Related Commands:** DIAG:OTDETECT:STATE ON | OFF

Usage DIAG:OTD:STATE? (@108) *enter statement returns either a 1 or a 0*

DIAGnostic:QUERy:SCPREAD?

DIAGnostic:QUERy:SCPREAD? <reg_addr> returns data word from a Signal Conditioning Plug-on register.

Parameters

Parameter Name	Parameter Type	Range of Values	Default Units
<i>reg_addr</i>	numeric (int32)	0-65,535	none

Comments • **Returned Value:** returns numeric register value. C-SCPI type is **int32**.

Usage DIAG:QUERY:SCPREAD? 258 *read Watchdog SCP's config/status register*
enter statement here *return SCP ID value*

DIAGnostic:VERSion?

DIAGnostic:VERSion? returns the version of the firmware currently loaded into Flash Memory. The version information includes manufacturer, model, serial number, firmware version and date.

Comments • **Returned Value:** Examples of the response string format:
HEWLETT-PACKARD,E1415,US34000478,A.04.00,Thu Aug 5 9:38:07 MDT 1994

HEWLETT-PACKARD,E1419,US34000478,A.04.00,Thu Aug 5 9:38:07 MDT 1994

- The C-SCPI type is **string**.
- **Related Commands:** *IDN?

Usage DIAG:VERS? *Returns version string as shown above*

Common Commands

This section describes IEEE-488.2 Common commands. See *Chapter 6 - Command Reference* in the *HP E1415A User's Manual* or *HP E1419A User's Manual* for Common Command fundamentals.

***CAL?** **Calibration Command.** The calibration command causes the Channel Calibration function to be performed for every module channel. The Channel Calibration function includes calibration of A/D Offset, and Gain and Offset for all 64 channels. This calibration is accomplished using internal calibration references.

• **Returned Value:**

Value	Meaning	Further Action
0	Cal OK	None
-1	Cal Error	Query the Error Queue (SYST?ERR?). See Error Messages in <i>Appendix B - Error Messages</i>

The C-SCPI type for this returned value is **int16**.

- **Related Commands:** CALibration:SETup, CALibration:SETup?
- Executing this command **does not** alter the module's programmed state (function, range etc.).

Note If Open Transducer Detect (OTD) is enabled when *CAL? is executed, the module will disable OTD, wait 1 minute to allow channels to settle, perform the calibration, and then re-enable OTD. If your program turns off OTD before executing *CAL?, it should also wait 1 minute for settling.

***CLS** **Clear Status Command.** The *CLS command clears all status event registers (Standard Event Status Event Register, Standard Operation Status Event Register, Questionable Data Event Register) and the instrument's error queue. This clears the corresponding summary bits (bits 3, 5, & 7) in the Status Byte Register.

*CLS does not affect the enable bits in any of the status register groups. (The SCPI command STATus:PRESet *does* clear the Operation Status Enable and Questionable Data Enable registers.) *CLS disables the Operation Complete function (*OPC command) and the Operation Complete Query function (*OPC? command).

***ESE <mask>** **Standard Event Status Enable Register Command.** Enables one or more events in the Standard Event Status Register to be reported in bit 5 (the Standard Event Status Summary Bit) of the Status Byte Register. You enable an event by specifying its decimal weight for <mask>. To enable more than one event (bit), specify the sum of the decimal weights. The C-SCPI type for <mask> is **int16**.

Bit #	7	6	5	4	3	2	1	0
Weighted Value	128	64	32	16	8	4	2	1
Event	Power-On	User Request	Command Error	Execution Error	Device Dependent Error	Query Error	Request Control	Operation Complete

***ESE?** **Standard Event Status Enable Query.** Returns the weighted sum of all enabled (unmasked) bits in the Standard Event Status Register. The C-SCPI type for this returned value is **int16**.

***ESR?** **Standard Event Status Register Query.** Returns the weighted sum of all set bits in the Standard Event Status Register. After reading the register, *ESR? clears the register. The events recorded in the Standard Event Status Register are independent of whether or not those events are enabled with the *ESE command to set the Standard Event Summary Bit in the Status Byte Register. The Standard Event bits are described in the *ESE command. The C-SCPI type for this returned value is **int16**.

***IDN?** **Identity.** Returns the device identity. The response consists of the following four fields (fields are separated by commas):

- Manufacturer
- Model Number
- Serial Number (returns 0 if not available)
- Firmware Revision (returns 0 if not available)

The *IDN? command returns the following command string (E1415A is shown; model will be either E1415A or E1419A):

HEWLETT-PACKARD,E1415A,<serial number>,<revision number>

The C-SCPI type for this returned value is **string**.

Note The revision will vary with the revision of the firmware installed in the instrument. This is the only indication of which version of the firmware is installed.

***OPC** **Operation Complete.** Causes an instrument to set bit 0 (Operation Complete Message) in the Standard Event Status Register when all pending operations have been completed. By enabling this bit to be reflected in the Status Byte Register (*ESE 1 command), you can ensure synchronization between the instrument and an external computer or between multiple instruments.

Note Do not use *OPC to determine when the CAL:SETUP or CAL:TARE commands have completed. Instead, use their query forms CAL:SETUP? or CAL:TARE?

***OPC?** **Operation Complete Query.** Causes an instrument to place a 1 into the instrument's output queue when all pending instrument operations are finished. By requiring your computer to read this response before continuing program execution, you can ensure synchronization between one or more instruments and the computer. The C-SCPI type for this returned value is **int16**.

Note Do not use *OPC? to determine when the CAL:SETUP or CAL:TARE commands have completed. Instead, use their query forms CAL:SETUP? or CAL:TARE?

***RST** **Reset Command.** Resets the HP E1415A or E1419A as follows:

- Sets all four scan lists to their default states:
 - Scan List 1 = ROUT:SEQ:DEF (@100:163)
 - Scan List 2 through 4 are zero length (*undefined*)
 - SENSE:FUNC:VOLT AUTO,(@100:163)
(all channels DCV, autorange)
- Sets the trigger system as follows:
 - TRIGGER:SOURCE HOLD
 - TRIGGER:TIMER 1E-4
 - TRIGGER:COUNT 1
 - ARM:SOURCE IMMEDIATE
- SAMPLE:TIMER 10E-6
- Aborts all pending operations, returns to Trigger Idle state
- Disables the *OPC and *OPC? modes
- MEMORY:VME:ADDRESS 240000;
MEMORY:VME:STATE OFF; MEMORY:VME:SIZE 0

*RST does not affect:

- Calibration data
- The output queue

- The Service Request Enable (SRE) register
- The Event Status Enable (ESE) register

***SRE <mask>**

Service Request Enable. When a service request event occurs, it sets a corresponding bit in the Status Byte Register (this happens whether or not the event has been enabled (unmasked) by *SRE). The *SRE command allows you to identify which of these events will assert an HP-IB service request (SRQ).

When an event is enabled by *SRE and that event occurs, it sets a bit in the Status Byte Register and issues an SRQ to the computer (sets the HP-IB SRQ line true). You enable an event by specifying its decimal weight for <mask>. To enable more than one event, specify the sum of the decimal weights. The C-SCPI type for <mask> is **int16**.

Bit #	7	6	5	4	3	2	1	0
Weighted Value	128	64	32	16	8	4	2	1
Event	Operation Status	Request Service	Standard Event	Message Available	Questionable Status	not used	not used	not used

***SRE?** **Status Register Enable Query.** Returns the weighted sum of all enabled (unmasked) events (those enabled to assert SRQ) in the Status Byte Register. The C-SCPI type for this returned value is **int16**.

***STB?** **Status Byte Register Query.** Returns the weighted sum of all set bits in the Status Byte Register. Refer to the *ESE command earlier in this chapter for a table showing the contents of the Status Byte Register. *STB? does not clear bit 6 (Service Request). The Message Available bit (bit 4) may be cleared as a result of reading the response to *STB?. The C-SCPI type for this returned value is **int16**.

***TRG** **Trigger.** Triggers an instrument when the trigger source is set to bus (TRIG:SOUR BUS command) and the instrument is in the Wait for Trigger state.

***TST?** **Self-Test.** Causes an instrument to execute extensive internal self-tests and returns a response showing the results of the self-test.

Note During the first 5 minutes after power is applied, *TST? may fail. Allow the module to warm-up before executing *TST?

Comments

• Returned Value:

The C-SCPI type for this returned value is **int16**.

- Following *TST?, the module is placed in the *RST state.
- *TST? performs the following tests on the HP E1415A/E1419A and installed Signal Conditioning Plug-ons (SCPs):

DIGITAL TESTS:

Test#	Description
1-3:	Writes and reads patterns to registers via A16 & A24
4-5:	Checks FIFO and CVT
6:	Checks measurement complete (Measuring) status bit
7:	Checks operation of FIFO half and FIFO full IRQ generation
8-9:	Checks trigger operation

ANALOG FRONT END DIGITAL TESTS:

Test#	Description
20:	Checks that SCP ID makes sense
30-32:	Checks relay driver and fet mux interface with EU CPU
33,71:	Checks opening of all relays on power down or input overvoltage
34-37:	Check fet mux interface with A/D digital

ANALOG TESTS:

Test#	Description
40-42:	Checks internal voltage reference
43-44:	Checks zero of A/D, internal cal source and relay drives
45-46:	Checks fine offset calibration DAC
47-48:	Checks coarse offset calibration DAC
49:	Checks internal + and -15V supplies
50-53:	Checks internal calibration source
54-55:	Checks gain calibration DAC
56-57:	Checks that autorange works
58-58:	Checks internal current source
60-63:	Checks front end and A/D noise and A/D filter
64:	Checks zeroing of coarse and fine offset calibration DACs
65-70:	Checks current source and CAL BUS relay and relay drives and OHM relay drive
71:	See 33
72-73:	Checks continuity through SCPs, bank relays and relay drivers
74:	Checks open transducer detect
75:	Checks current leakage of the SCPs
76:	Checks voltage offset of the SCPs
80:	Checks mid-scale strain dac output. Only reports first SCP channel.
81:	Checks range of strain dac. Only reports first channel of SCP.
82:	Checks noise of strain dac. Only reports first channel of SCP.
83:	Checks bridge completion leg resistance each channel.
84:	Checks combined leg resistance each channel.

- 86: Checks current source SCP's OFF current.
- 87: Checks current source SCP's current dac mid-scale.
- 88: Checks current source SCP's current dac range on HI and LO ranges.
- 89: Checks current source compliance
- 90: Checks strain SCP's Wagner Voltage control.
- 91: Checks autobalance dac range with input shorted.
- 92: Sample and Hold channel holds value even when input value changed.
- 93: Sample and Hold channel held value test for droop rate.

ANALOG OUTPUT AND DIGITAL I/O TESTS

- 301: Current and Voltage Output SCPs digital DAC control.
- 302: Current and Voltage Output SCPs DAC noise.
- 303: Current Output SCP offset
- 304: Current Output SCP gain shift
- 305: Current Output SCP offset
- 306: Current Output SCP linearity
- 307: Current Output SCP linearity
- 308: Current Output SCP turn over

- 313: Voltage Output SCP offset
- 315: Voltage Output SCP offset
- 316: Voltage Output SCP linearity
- 317: Voltage Output SCP linearity
- 318: Voltage Output SCP turn over

- 331: Digital I/O SCP internal digital interface
- 332: Digital I/O SCP user input
- 333: Digital I/O SCP user input
- 334: Digital I/O SCP user output
- 335: Digital I/O SCP user output
- 336: Digital I/O SCP output current
- 337: Digital I/O SCP output current

- 341: Freq/PWM/FM SCP internal data0 register
- 342: Freq/PWM/FM SCP internal data1 register
- 343: Freq/PWM/FM SCP internal parameter register
- 344: Freq/PWM/FM SCP on-board processor self-test
- 345: Freq/PWM/FM SCP on-board processor self-test
- 346: Freq/PWM/FM SCP user inputs
- 347: Freq/PWM/FM SCP user outputs
- 348: Freq/PWM/FM SCP outputs ACTIVE/PASSive
- 349: Freq/PWM/FM SCP output interrupts

- 350: Watchdog SCP enable/disable timer
- 351: Watchdog SCP relay drive and coil closed
- 352: Watchdog SCP relay drive and coil open
- 353: Watchdog SCP I/O Disconnect line
- 354: Watchdog SCP I/O Disconnect supply

***WAI** **Wait-to-Continue.** Prevents an instrument from executing another command until the operation begun by the previous command is finished (sequential operation).

Note Do not use *WAI to determine when the CAL:SETUP or CAL:TARE commands have completed. Instead, use their query forms CAL:SETUP? or CAL:TARE?. CAL:SETUP? and CAL:TARE? return a value only after the CAL:SETUP or CAL:TARE operations are complete.
